

W3G500-GD01-51 ebmpapst Datasheet

sales@fansco.com

www.fansco.com

Nominal data

Type	W3G500-GD01-51	
Motor	M3G084-GF	
Phase		1~
Nominal voltage	VAC	230
Nominal voltage range	VAC	200 .. 277
Frequency	Hz	50/60
Type of data definition		ml
Speed	min ⁻¹	1100
Power input	W	360
Current draw	A	2.2
Max. back pressure	Pa	100
Min. ambient temperature	°C	-25
Max. ambient temperature	°C	+55

ml = Max. load · me = Max. efficiency · fa = Running at free air · cs = Customer specs · cu = Customer unit
Subject to alterations

Data according to ErP directive

		Actual	Request 2013	Request 2015
Installation category	A			
Efficiency category	Static			
Variable speed drive	Yes			
Specific ratio*	1.00			
Overall efficiency η_{es}		40.8	26.9	30.9
Efficiency grade N		49.9	36	40
Power input P_{ed}	kW	0.36		
Air flow q_v	m ³ /h	4585		
Pressure increase p_{fs}	Pa	106		
Speed n	min ⁻¹	1105		

Data definition with optimum efficiency.

* Specific ratio = $1 + p_b / 100\,000\text{ Pa}$ 

Technical features

Mass	12 kg
Size	500 mm
Surface of rotor	Coated in black
Material of blades	Press-fitted sheet steel blank, sprayed with PP plastic
Material of wall ring	Sheet steel, pre-galvanised and coated in black plastic (RAL 9005)
Material of guard grille	Steel, coated in black plastic (RAL9005)
Number of blades	5
Direction of air flow	"V"
Direction of rotation	Counter-clockwise, seen on rotor
Type of protection	IP 54
Insulation class	"B"
Humidity class	F3-1
Max. permissible ambient motor temp. (transp./ storage)	+ 80 °C
Min. permissible ambient motor temp. (transp./storage)	- 40 °C
Mounting position	Shaft horizontal or rotor on bottom; rotor on top on request
Condensate discharge holes	Rotor-side
Operation mode	S1
Motor bearing	Ball bearing
Technical features	<ul style="list-style-type: none"> - Output 10 VDC, max. 1.1 mA - Alarm relay - Motor current limit - Soft start - Control input 0-10 VDC / PWM - Control interface with SELV potential safely disconnected from the mains - Over-temperature protected electronics / motor - Line undervoltage detection
EMC interference immunity	Acc. to EN 61000-6-2 (industrial environment)
EMC harmonics	Acc. to EN 61000-3-2/3
EMC interference emission	Acc. to EN 61000-6-3 (household environment)
Touch current acc. IEC 60990 (measuring network Fig. 4, TN system)	<= 3.5 mA
Motor protection	Thermal overload protector (TOP) wired internally
Cable exit	Variable
Protection class	I (if protective earth is connected by customer)
Product conforming to standard	EN 61800-5-1; CE
Approval	GOST

EC axial fan - HyBlade®

sickled blades (S series)

with full square nozzle

Product drawing

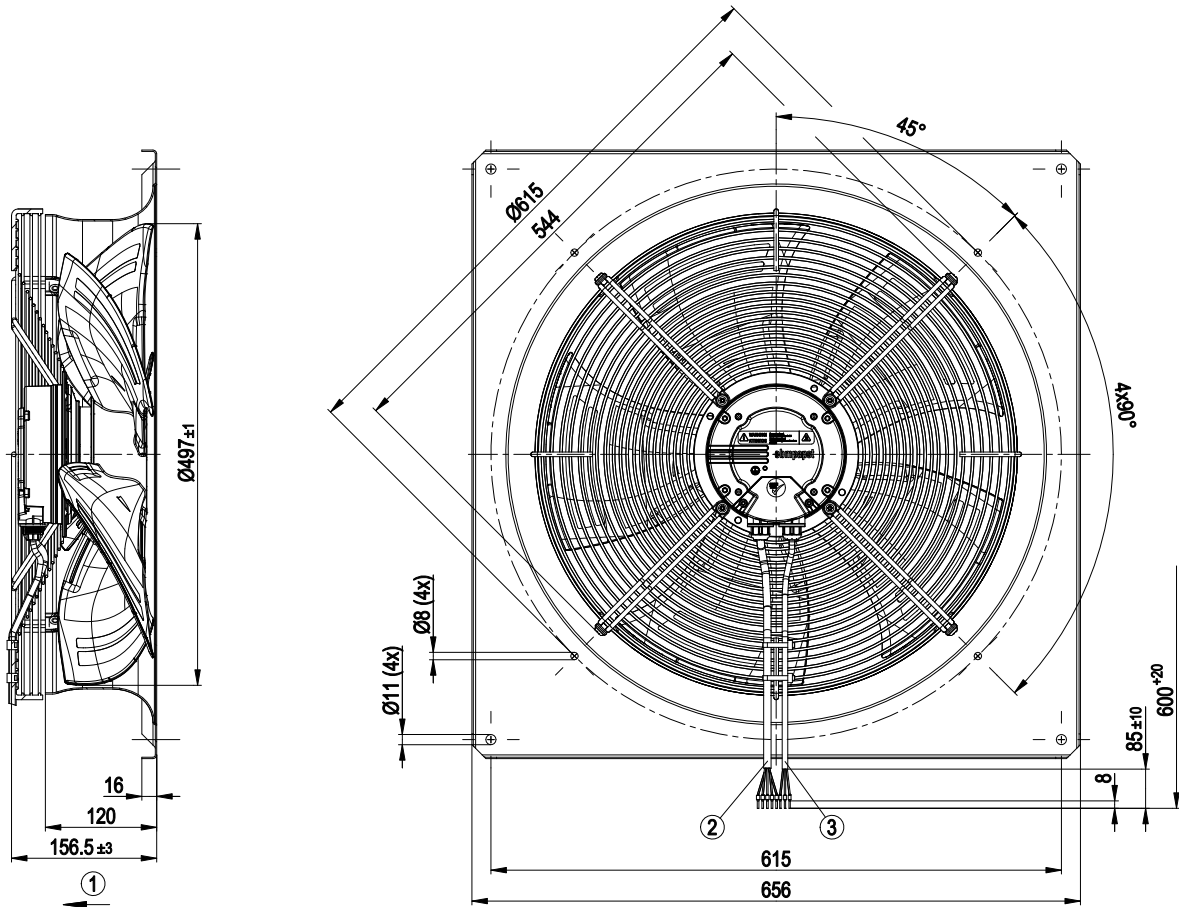

- | | |
|---|--|
| 1 | Direction of air flow "V" |
| 2 | Connection line PVC AWG18, 5x crimped core-end sleeves |
| 3 | Connection line PVC AWG22, 3x crimped core-end sleeves |



Connection screen

Customer circuit

Notes on various control possibilities and their applications

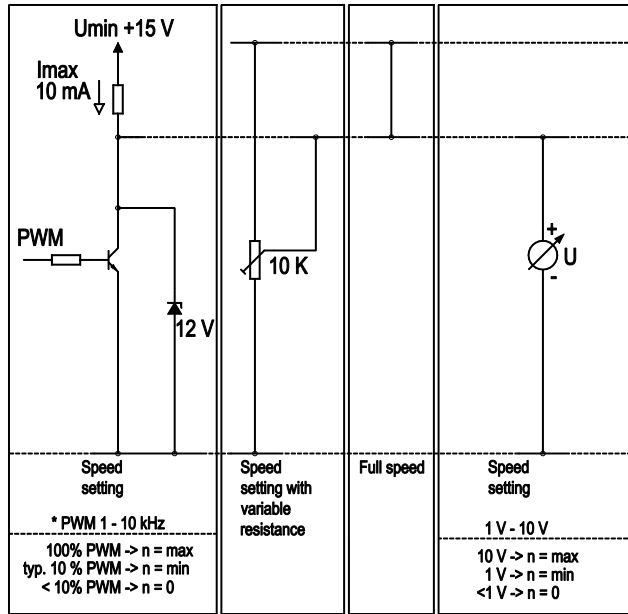

Connection

Fan / motor

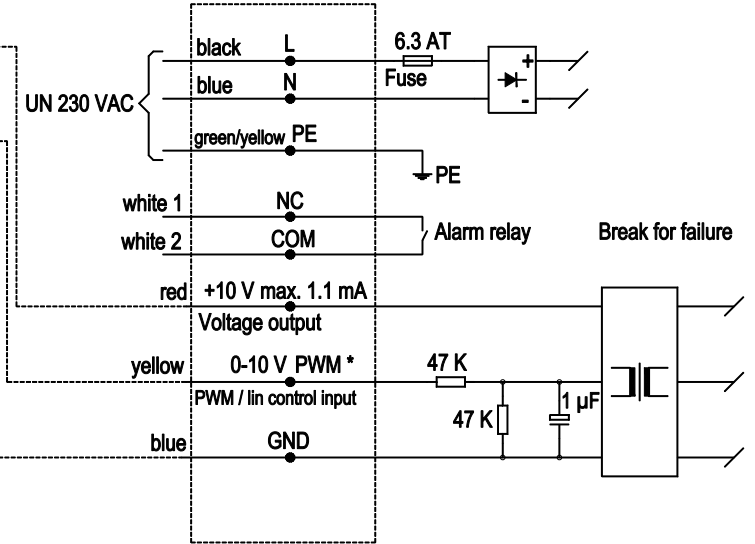

Charts: Air flow 50 Hz

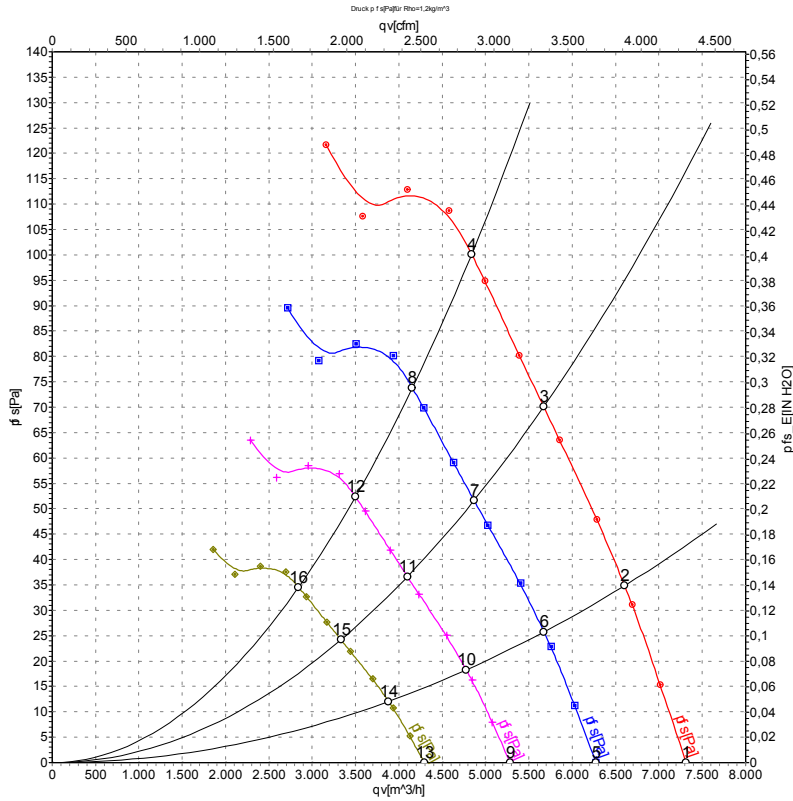

Measurement: LU-114485

Air performance measured as per ISO 5801 Installation category A. For detailed information on the measuring set-up, please contact ebmpapst. Suction-side noise levels: LwA measured as per ISO 13347 / LpA measured with 1m distance to fan axis. The values given are valid under the measuring conditions mentioned above and may vary according to the actual installation situation. With any deviation from the standard set-up, the specific values have to be checked and reviewed with the unit installed.

Measured values

	Conn.	U	f	n	P _{ed}	I	LpA _{in}	LwA _{in}	LwA _{out}	qv	p _{fs}
		V	Hz	min ⁻¹	W	A	dB(A)	dB(A)	dB(A)	m³/h	Pa
1	Δ	230	50	1100	264	1.62	61	68	68	7315	0
2	Δ	230	50	1100	301	1.82	60	66	66	6605	35
3	Δ	230	50	1100	336	2.02	59	65	65	5670	70
4	Δ	230	50	1100	360	2.20	60	66	66	4840	100
5	Δ	230	50	950	166	1.02	58	65	64	6270	0
6	Δ	230	50	950	191	1.15	56	63	62	5675	26
7	Δ	230	50	950	213	1.27	55	62	62	4870	52
8	Δ	230	50	950	228	1.37	56	63	62	4155	74
9	Δ	230	50	800	99	0.61	54	61	61	5280	0
10	Δ	230	50	800	114	0.69	53	59	59	4775	18
11	Δ	230	50	800	127	0.76	52	58	58	4100	37
12	Δ	230	50	800	136	0.82	53	59	59	3500	52
13	Δ	230	50	650	53	0.33	50	56	56	4290	0
14	Δ	230	50	650	61	0.37	48	55	54	3880	12
15	Δ	230	50	650	68	0.41	47	54	53	3330	24
16	Δ	230	50	650	73	0.44	48	55	54	2840	34

Conn. = Connection · U = Supply voltage · f = Frequency · n = Speed · P_{ed} = Power input · I = Current draw · LpA_{in} = Sound pressure level inlet side · LwA_{in} = Sound power level inlet side
LwA_{out} = Sound power level outlet side · qv = Air flow · p_{fs} = Pressure increase

