

# EC axial fan - HyBlade

sickle-shaped blades (S series)

with round full nozzle

W3G450-CC28-52 ebmpapst Datasheet FansCo

sales@fansco.com

www.fansco.com

## Nominal data

Type	W3G450-CC28-52	
Motor	M3G084-FA	
Phase		1~
Nominal voltage	VAC	230
Nominal voltage range	VAC	200 .. 277
Frequency	Hz	50/60
Method of obtaining data		ml
Speed (rpm)	min <sup>-1</sup>	1300
Power consumption	W	345
Current draw	A	2.2
Max. back pressure	Pa	125
Max. back pressure	in. wg	0.5
Min. ambient temperature	°C	-25
Max. ambient temperature	°C	60

ml = Max. load · me = Max. efficiency · fa = Free air · cs = Customer specification · ce = Customer equipment  
Subject to change

## Data according to Commission Regulation (EU) 327/2011

		Actual	Req. 2015
01 Overall efficiency $\eta_{es}$	%	42.6	30.7
02 Measurement category		A	
03 Efficiency category		Static	
04 Efficiency grade N		51.9	40
05 Variable speed drive		Yes	

Data obtained at optimum efficiency level.  
The ErP data is determined using a motor-impeller combination in a standardized measurement setup.

09 Power consumption $P_{ed}$	kW	0.34
09 Air flow $q_v$	m <sup>3</sup> /h	4005
09 Pressure increase $p_{fs}$	Pa	118
10 Speed (rpm) n	min <sup>-1</sup>	1305
11 Specific ratio*		1.00

\* Specific ratio =  $1 + p_{fs} / 100\,000\text{ Pa}$

LU-124620



# EC axial fan - HyBlade

sickle-shaped blades (S series)

with round full nozzle

## Technical description

<b>Weight</b>	9.7 kg
<b>Size</b>	450 mm
<b>Motor size</b>	84
<b>Rotor surface</b>	Painted black
<b>Electronics housing material</b>	Die-cast aluminum
<b>Blade material</b>	Press-fitted sheet steel blank, sprayed with PP plastic
<b>Fan housing material</b>	Sheet steel, pre-galvanized and coated with black plastic
<b>Guard grille material</b>	Steel, phosphated and coated with black plastic
<b>Number of blades</b>	5
<b>Airflow direction</b>	A
<b>Direction of rotation</b>	Clockwise, viewed toward rotor
<b>Degree of protection</b>	IP54
<b>Insulation class</b>	"B"
<b>Moisture (F) / Environmental (H) protection class</b>	H2
<b>Max. permitted ambient temp. for motor (transport/storage)</b>	+80 °C
<b>Min. permitted ambient temp. for motor (transport/storage)</b>	-40 °C
<b>Installation position</b>	Shaft horizontal or rotor on bottom; rotor on top on request
<b>Condensation drainage holes</b>	On rotor side
<b>Mode</b>	S1
<b>Motor bearing</b>	Ball bearing
<b>Technical features</b>	<ul style="list-style-type: none"> <li>- Output 10 VDC, max. 1.1 mA</li> <li>- Alarm relay</li> <li>- Motor current limitation</li> <li>- Soft start</li> <li>- Control input 0-10 VDC / PWM</li> <li>- Thermal overload protection for electronics/motor</li> <li>- Line undervoltage detection</li> </ul>
<b>EMC immunity to interference</b>	According to EN 61000-6-2 (industrial environment)
<b>EMC circuit feedback</b>	According to EN 61000-3-2/3
<b>EMC interference emission</b>	According to EN 61000-6-3 (household environment)
<b>Touch current according to IEC 60990 (measuring circuit Fig. 4, TN system)</b>	<= 3.5 mA
<b>Motor protection</b>	Thermal overload protector (TOP) internally connected
<b>With cable</b>	Variable
<b>Protection class</b>	I (with customer connection of protective earth)
<b>Conformity with standards</b>	EN 61800-5-1; CE
<b>Approval</b>	UL 1004-3 + 60730-1; EAC; CCC; CSA C22.2 No. 77 + CAN/CSA-E60730-1



# EC axial fan - HyBlade

sickle-shaped blades (S series)

with round full nozzle

## Product drawing

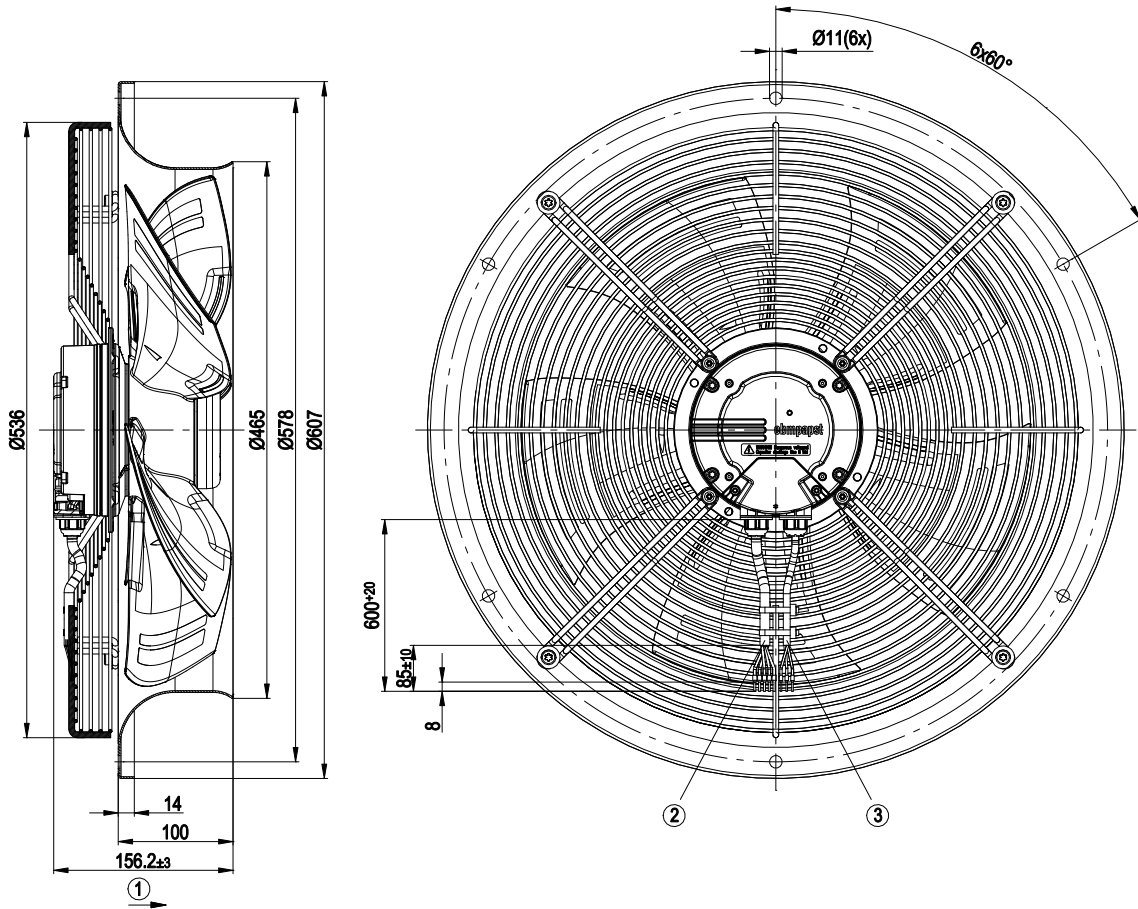

1	Direction of air flow "A"
2	Cable PVC AWG18, 5x crimped ferrules
3	Cable PVC AWG22, 3x crimped ferrules



# EC axial fan - HyBlade

sickle-shaped blades (S series)

with round full nozzle

## Connection diagram

Customer circuit

Application notes for various control options

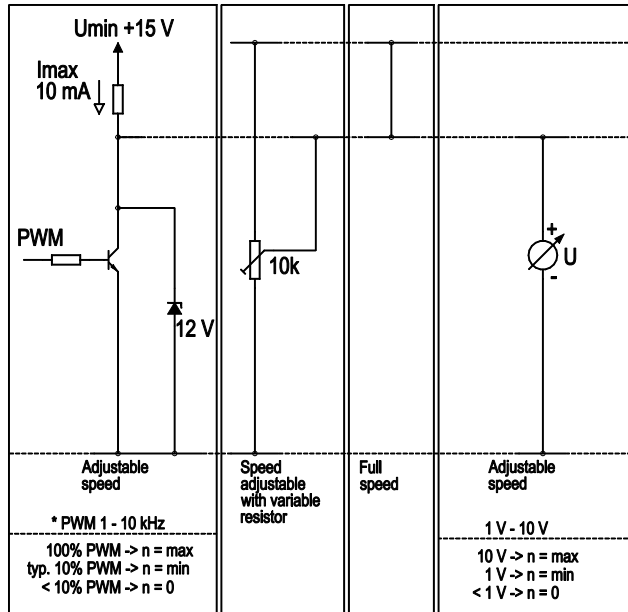

Connection

Fan / Motor

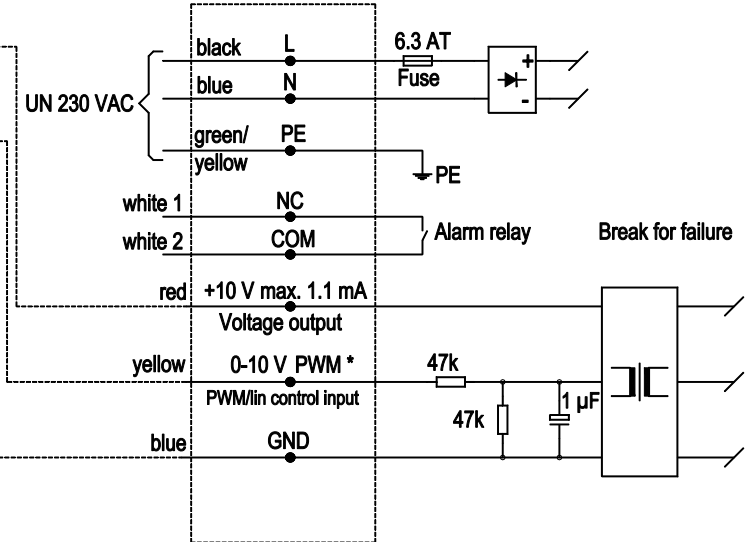

## Curves: Air performance 50 Hz

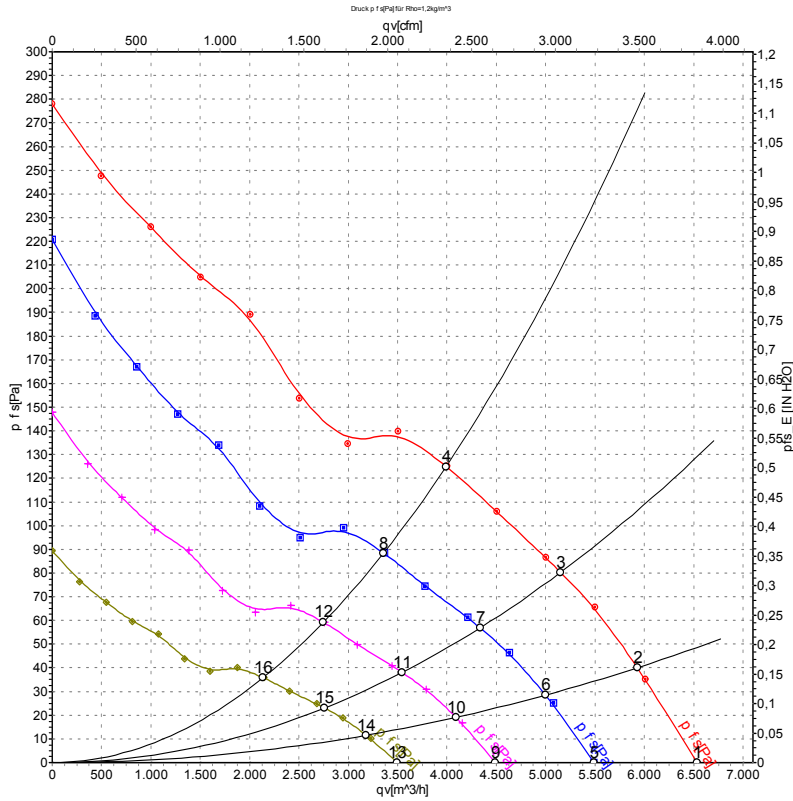

Measurement: LU-124620-1

Air performance measured according to ISO 5801 installation category A. For detailed information on the measurement setup, contact ebmpapst. Intake sound level: Sound power level according to ISO 13347 / sound pressure level measured at 1 m distance from fan axis. The values given are valid under the specified measuring conditions and may vary due to conditions of installation. For deviations from the standard configuration, the parameters have to be checked on the installed unit.

## Measured values

	U	f	n	P <sub>ed</sub>	I	LpA <sub>in</sub>	LwA <sub>in</sub>	LwA <sub>out</sub>	q <sub>v</sub>	p <sub>fs</sub>	q <sub>v</sub>	p <sub>fs</sub>
	V	Hz	min <sup>-1</sup>	W	A	dB(A)	dB(A)	dB(A)	m <sup>3</sup> /h	Pa	cfm	in. wg
1	230	50	1300	270	1.72	65	71	72	6535	0	3845	0.00
2	230	50	1300	298	1.91	62	68	69	5925	40	3490	0.16
3	230	50	1300	326	2.07	60	65	67	5150	80	3030	0.32
4	230	50	1300	345	2.20	61	67	68	3990	125	2350	0.50
5	230	50	1100	160	1.02	61	67	68	5490	0	3230	0.00
6	230	50	1100	179	1.15	58	64	65	4995	29	2940	0.12
7	230	50	1100	194	1.23	56	62	63	4335	57	2550	0.23
8	230	50	1100	205	1.30	57	63	64	3360	89	1975	0.36
9	230	50	900	87	0.56	57	63	64	4490	0	2645	0.00
10	230	50	900	98	0.63	54	60	61	4090	19	2405	0.08
11	230	50	900	106	0.68	52	57	59	3545	38	2085	0.15
12	230	50	900	112	0.71	53	59	60	2745	60	1615	0.24
13	230	50	700	41	0.26	51	57	58	3490	0	2055	0.00
14	230	50	700	46	0.30	48	55	56	3180	12	1870	0.05
15	230	50	700	50	0.32	46	52	53	2760	23	1625	0.09
16	230	50	700	53	0.34	47	54	54	2135	36	1260	0.14

U = Voltage · f = Frequency · n = Speed (rpm) · P<sub>ed</sub> = Power consumption · I = Current draw · LpA<sub>in</sub> = Sound pressure level intake side · LwA<sub>in</sub> = Sound power level intake side  
 LwA<sub>out</sub> = Sound power level outlet side · q<sub>v</sub> = Air flow · p<sub>fs</sub> = Pressure increase

