

W3G450-CC28-51 ebmpapst Datasheet

sales@fansco.com

www.fansco.com

## Nominal data

Type	W3G450-CC28-51	
Motor	M3G084-FA	
Phase		1~
Nominal voltage	VAC	230
Nominal voltage range	VAC	200 .. 277
Frequency	Hz	50/60
Type of data definition		ml
Speed	min <sup>-1</sup>	1300
Power input	W	345
Current draw	A	2.2
Max. back pressure	Pa	125
Min. ambient temperature	°C	-25
Max. ambient temperature	°C	60

ml = Max. load · me = Max. efficiency · fa = Running at free air · cs = Customer specs · cu = Customer unit  
Subject to alterations

## Data according to ErP directive

Installation category	A
Efficiency category	Static
Variable speed drive	Yes
Specific ratio*	1.00

\* Specific ratio =  $1 + p_{fs} / 100\,000\text{ Pa}$

		Actual	Request 2013	Request 2015
Overall efficiency $\eta_{es}$	%	42.6	26.7	30.7
Efficiency grade N		51.9	36	40
Power input $P_{ed}$	kW	0.34		
Air flow $q_v$	m <sup>3</sup> /h	4005		
Pressure increase $p_{fs}$	Pa	118		
Speed n	min <sup>-1</sup>	1305		

Data definition with optimum efficiency.

LU-124620

The ErP data is determined using a motor-impeller combination in a standardised measurement configuration.



## Technical features

Mass	9.5 kg
Size	450 mm
Surface of rotor	Coated in black
Material of electronics housing	Die-cast aluminium
Material of blades	Press-fitted sheet steel blank, sprayed with PP plastic
Material of wall ring	Sheet steel, pre-galvanised and coated in black plastic
Material of guard grille	Steel, phosphated and coated in black plastic
Number of blades	5
Direction of air flow	"V"
Direction of rotation	Counter-clockwise, seen on rotor
Type of protection	IP 54
Insulation class	"B"
Humidity class	F3-1
Max. permissible ambient motor temp. (transp./ storage)	+80 °C
Min. permissible ambient motor temp. (transp./storage)	-40 °C
Mounting position	Shaft horizontal or rotor on bottom; rotor on top on request
Condensate discharge holes	Rotor-side
Operation mode	S1
Motor bearing	Ball bearing
Technical features	<ul style="list-style-type: none"> <li>- Output 10 VDC, max. 1.1 mA</li> <li>- Alarm relay</li> <li>- Motor current limit</li> <li>- Soft start</li> <li>- Control input 0-10 VDC / PWM</li> <li>- Control interface with SELV potential safely disconnected from the mains</li> <li>- Over-temperature protected electronics / motor</li> <li>- Line undervoltage detection</li> </ul>
EMC interference immunity	Acc. to EN 61000-6-2 (industrial environment)
EMC harmonics	Acc. to EN 61000-3-2/3
EMC interference emission	Acc. to EN 61000-6-3 (household environment)
Touch current acc. IEC 60990 (measuring network Fig. 4, TN system)	<= 3.5 mA
Motor protection	Thermal overload protector (TOP) wired internally
Cable exit	Variable
Protection class	I (if protective earth is connected by customer)
Product conforming to standard	EN 61800-5-1; CE
Approval	CCC; CSA C22.2 Nr.77; EAC; UL 2111

# EC axial fan - HyBlade®

sickled blades (S series)

with full round nozzle

## Product drawing

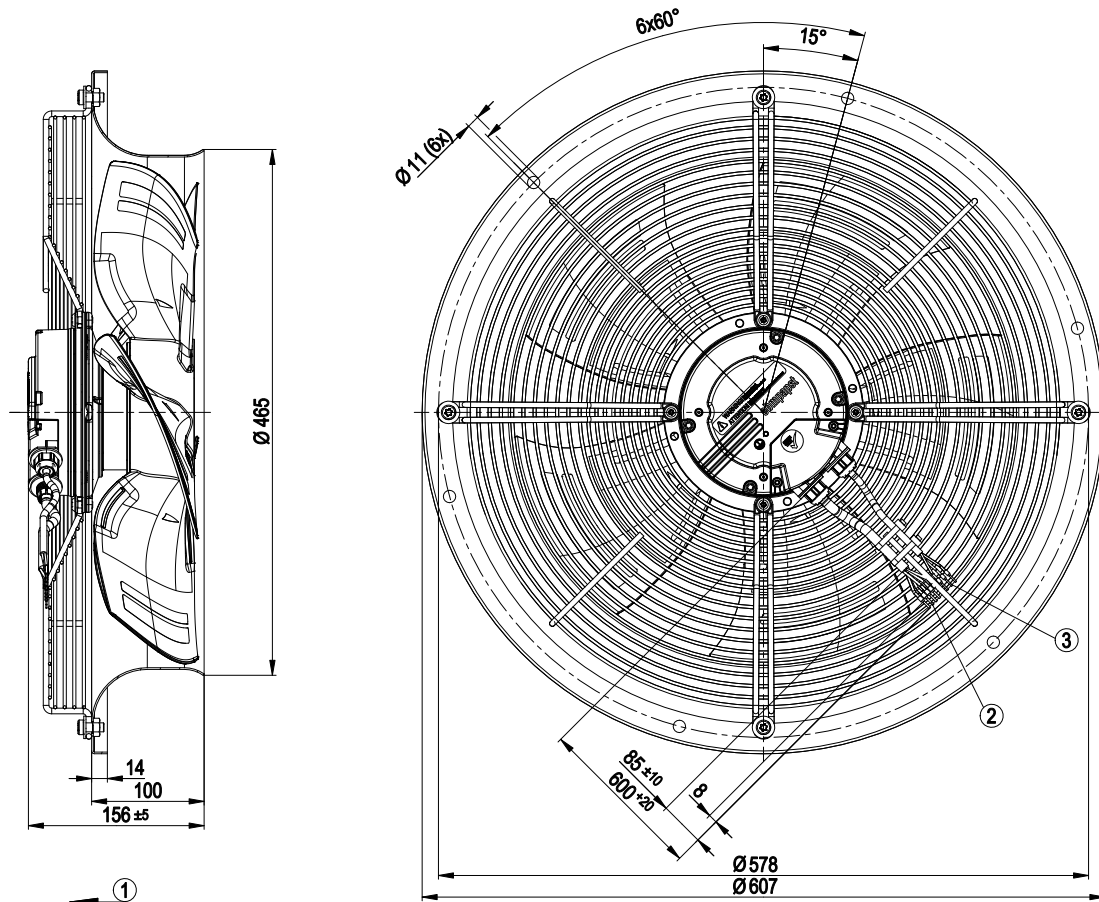

1	Direction of air flow "V"
2	Connection line PVC AWG 18, 5 x crimped core-end sleeves
3	Connection line PVC AWG 22, 3x crimped core-end sleeves



## Connection screen

### Customer circuit

Notes on various control possibilities and their applications

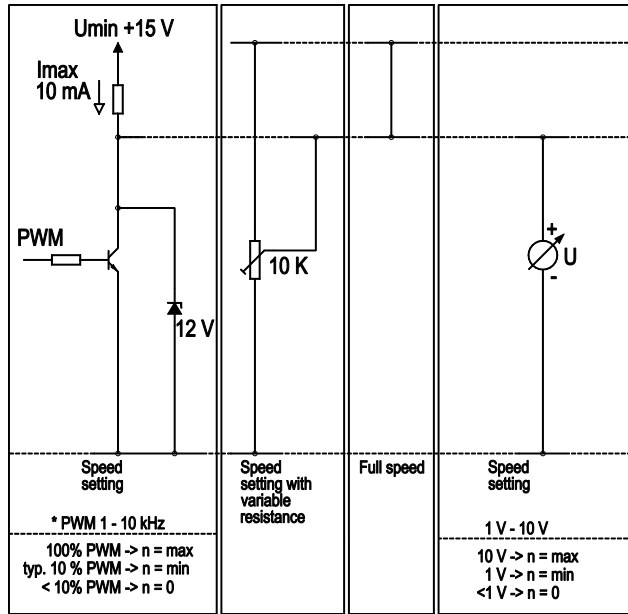

### Connection

### Fan / motor

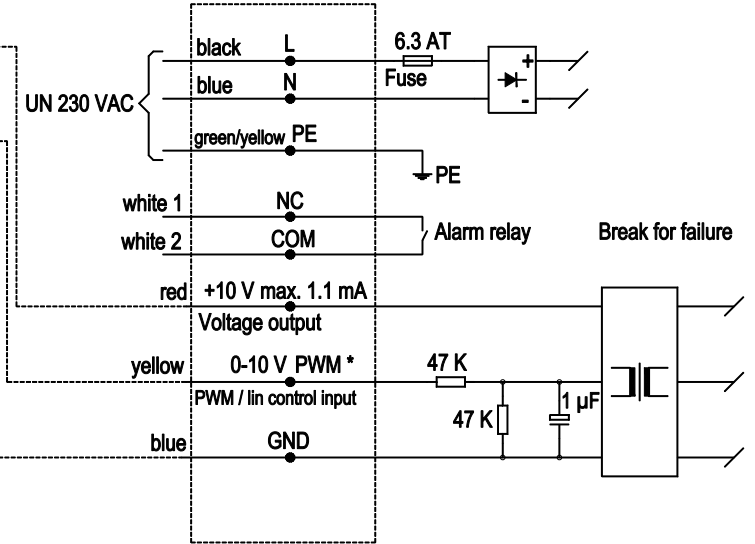

## Charts: Air flow 50 Hz

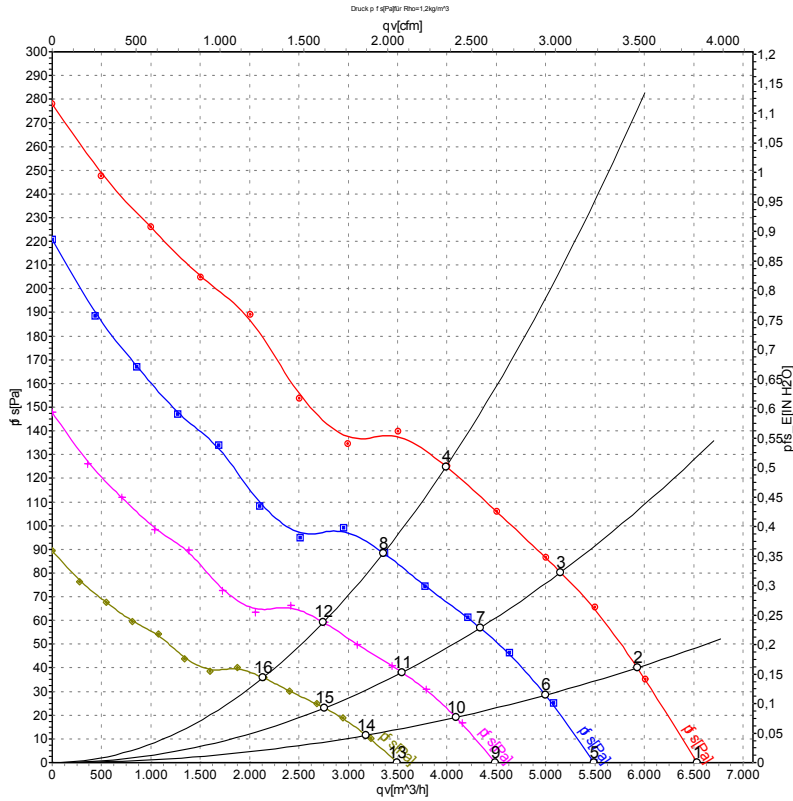

Air performance measured as per ISO 5801 Installation category A. For detailed information on the measuring set-up, please contact ebmpapst. Suction-side noise levels: LwA measured as per ISO 13347 / LpA measured with 1m distance to fan axis. The values given are valid under the measuring conditions mentioned above and may vary according to the actual installation situation. With any deviation from the standard set-up, the specific values have to be checked and reviewed with the unit installed.

## Measured values

	U	f	n	P <sub>ed</sub>	I	LpA <sub>in</sub>	LwA <sub>in</sub>	LwA <sub>out</sub>	qv	p <sub>fs</sub>
	V	Hz	min <sup>-1</sup>	W	A	dB(A)	dB(A)	dB(A)	m <sup>3</sup> /h	Pa
1	230	50	1300	270	1.72	65	71	72	6535	0
2	230	50	1300	298	1.91	62	68	69	5925	40
3	230	50	1300	326	2.07	60	65	67	5150	80
4	230	50	1300	345	2.20	61	67	68	3990	125
5	230	50	1100	160	1.02	61	67	68	5490	0
6	230	50	1100	179	1.15	58	64	65	4995	29
7	230	50	1100	194	1.23	56	62	63	4335	57
8	230	50	1100	205	1.30	57	63	64	3360	89
9	230	50	900	87	0.56	57	63	64	4490	0
10	230	50	900	98	0.63	54	60	61	4090	19
11	230	50	900	106	0.68	52	57	59	3545	38
12	230	50	900	112	0.71	53	59	60	2745	60
13	230	50	700	41	0.26	51	57	58	3490	0
14	230	50	700	46	0.30	48	55	56	3180	12
15	230	50	700	50	0.32	46	52	53	2760	23
16	230	50	700	53	0.34	47	54	54	2135	36

U = Supply voltage · f = Frequency · n = Speed · P<sub>ed</sub> = Power input · I = Current draw · LpA<sub>in</sub> = Sound pressure level inlet side · LwA<sub>in</sub> = Sound power level inlet side · LwA<sub>out</sub> = Sound power level outlet side  
 qv = Air flow · p<sub>fs</sub> = Pressure increase

