

EC axial fan - HyBlade

sickle-shaped blades (S series)

with round full nozzle

W3G400-CC22-52 ebmpapst Datasheet

sales@fansco.com

www.fansco.com

Nominal data

Type	W3G400-CC22-52	
Motor	M3G084-FA	
Phase		1~
Nominal voltage	VAC	230
Nominal voltage range	VAC	200 .. 277
Frequency	Hz	50/60
Method of obtaining data		ml
Speed (rpm)	min ⁻¹	1630
Power consumption	W	400
Current draw	A	2.6
Max. back pressure	Pa	160
Max. back pressure	in. wg	0.64
Min. ambient temperature	°C	-25
Max. ambient temperature	°C	60

ml = Max. load · me = Max. efficiency · fa = Free air · cs = Customer specification · ce = Customer equipment
Subject to change

Data according to Commission Regulation (EU) 327/2011

		Actual	Req. 2015			
01 Overall efficiency η_{es}	%	39.7	31.1	09 Power consumption P_{ed}	kW	0.39
02 Measurement category		A		09 Air flow q_v	m ³ /h	3605
03 Efficiency category		Static		09 Pressure increase p_{fs}	Pa	142
04 Efficiency grade N		48.6	40	10 Speed (rpm) n	min ⁻¹	1635
05 Variable speed drive		Yes		11 Specific ratio*		1.00

Data obtained at optimum efficiency level.

The ErP data is determined using a motor-impeller combination in a standardized measurement setup.

* Specific ratio = $1 + p_s / 100\,000\text{ Pa}$

LU-124564



Technical description

Weight	8.7 kg
Size	400 mm
Motor size	84
Rotor surface	Painted black
Electronics housing material	Die-cast aluminum
Blade material	Press-fitted sheet steel blank, sprayed with PP plastic
Fan housing material	Sheet steel, pre-galvanized and coated with black plastic
Guard grille material	Steel, phosphated and coated with black plastic
Number of blades	5
Airflow direction	A
Direction of rotation	Clockwise, viewed toward rotor
Degree of protection	IP54
Insulation class	"B"
Moisture (F) / Environmental (H) protection class	H2
Max. permitted ambient temp. for motor (transport/storage)	+80 °C
Min. permitted ambient temp. for motor (transport/storage)	-40 °C
Installation position	Shaft horizontal or rotor on bottom; rotor on top on request
Condensation drainage holes	On rotor side
Mode	S1
Motor bearing	Ball bearing
Technical features	<ul style="list-style-type: none"> - Output 10 VDC, max. 1.1 mA - Alarm relay - Motor current limitation - Soft start - Control input 0-10 VDC / PWM - Thermal overload protection for electronics/motor - Line undervoltage detection
EMC immunity to interference	According to EN 61000-6-2 (industrial environment)
EMC circuit feedback	According to EN 61000-3-2/3
EMC interference emission	According to EN 61000-6-3 (household environment)
Touch current according to IEC 60990 (measuring circuit Fig. 4, TN system)	<= 3.5 mA
Motor protection	Thermal overload protector (TOP) internally connected
With cable	Variable
Protection class	I (with customer connection of protective earth)
Conformity with standards	EN 61800-5-1; CE
Approval	UL 1004-3 + 60730-1; EAC; CCC; CSA C22.2 No. 77 + CAN/CSA-E60730-1

EC axial fan - HyBlade

sickle-shaped blades (S series)

with round full nozzle

Product drawing

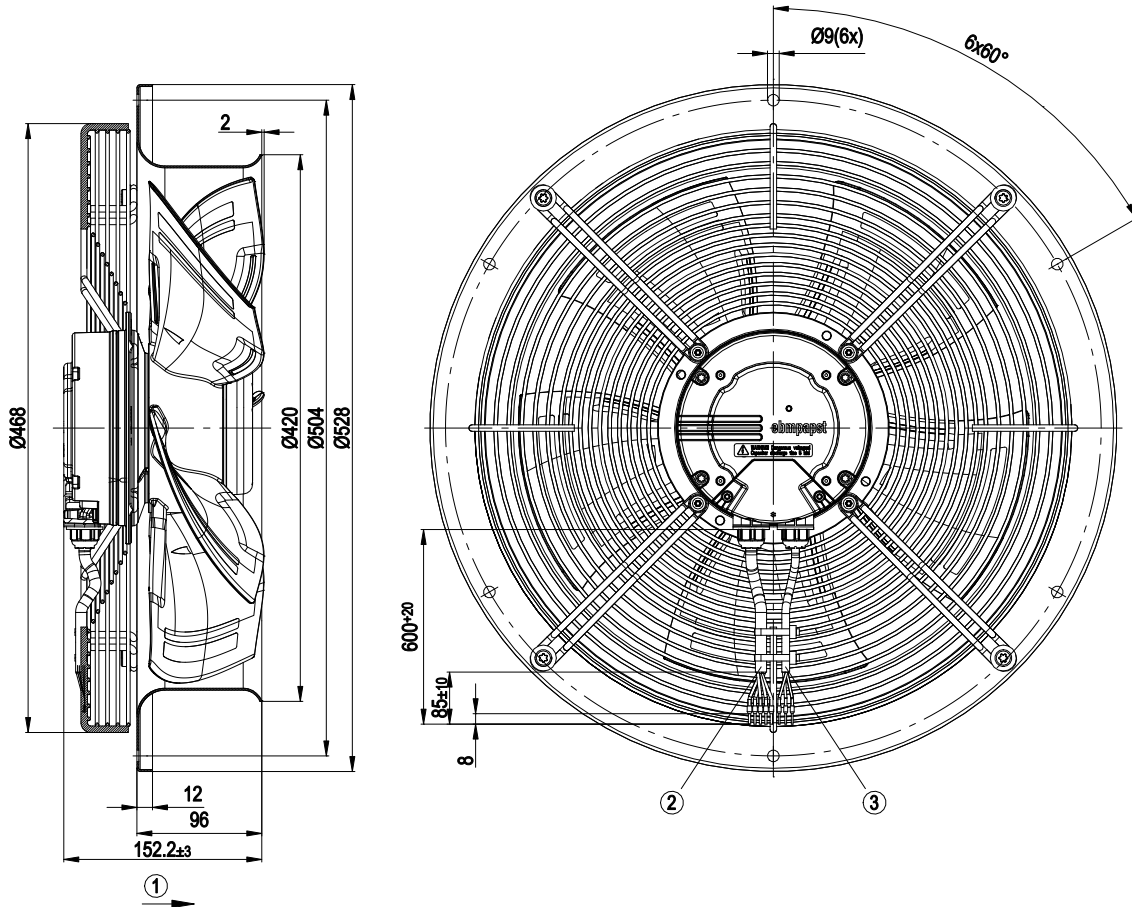

1	Direction of air flow "A"
2	Cable PVC AWG18; 5x crimped ferrules
3	Cable PVC AWG22; 3x crimped ferrules



EC axial fan - HyBlade

sickle-shaped blades (S series)

with round full nozzle

Connection diagram

Customer circuit

Application notes for various control options

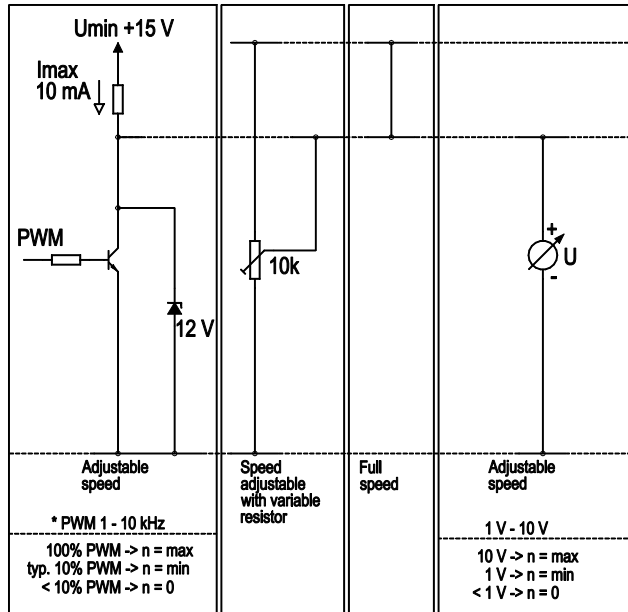

Connection

Fan / Motor

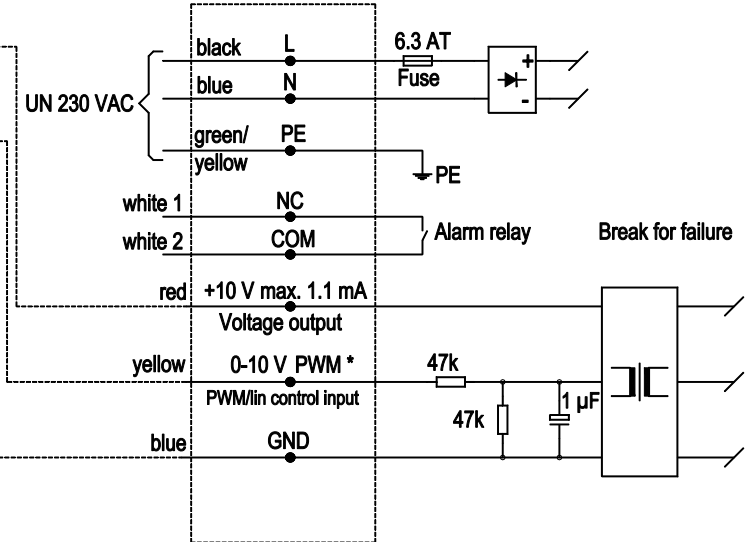

Curves: Air performance 50 Hz

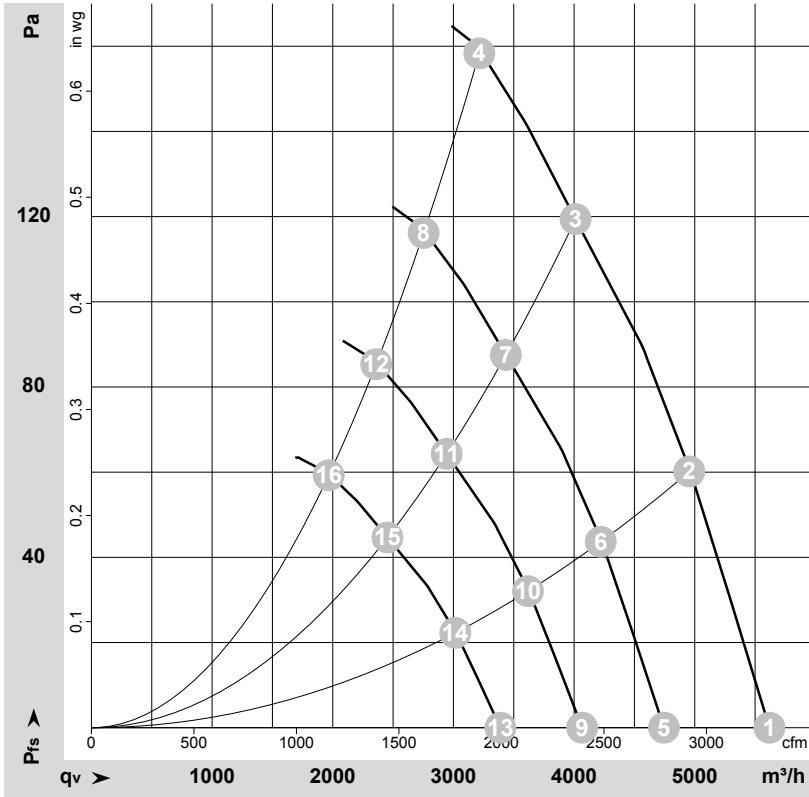

$\rho = 1.15 \text{ kg/m}^3 \pm 2 \%$

Measurement: LU-124564-1

Air performance measured according to ISO 5801 installation category A. For detailed information on the measurement setup, contact ebmpapst. Intake sound level: Sound power level according to ISO 13347 / sound pressure level measured at 1 m distance from fan axis. The values given are valid under the specified measuring conditions and may vary due to conditions of installation. For deviations from the standard configuration, the parameters have to be checked on the installed unit.

Measured values

	U	f	n	P _{ed}	I	LpA _{in}	LwA _{in}	q _v	P _{fs}	q _v	P _{fs}
	V	Hz	min ⁻¹	W	A	dB(A)	dB(A)	m ³ /h	Pa	cfm	in. wg
1	230	50	1660	350	2.24	71	78	5620	0	3305	0.00
2	230	50	1645	381	2.44	69	76	4955	60	2915	0.24
3	230	50	1635	392	2.50	66	72	4010	120	2360	0.48
4	230	50	1630	400	2.60	71	79	3215	160	1890	0.64
5	230	50	1400	211	1.35	66	73	4745	0	2795	0.00
6	230	50	1400	236	1.51	65	71	4220	44	2485	0.18
7	230	50	1400	246	1.57	62	68	3435	88	2020	0.35
8	230	50	1400	251	1.59	67	75	2755	117	1620	0.47
9	230	50	1200	133	0.85	63	69	4065	0	2395	0.00
10	230	50	1200	148	0.95	61	68	3620	33	2130	0.13
11	230	50	1200	155	0.99	58	64	2945	64	1735	0.26
12	230	50	1200	158	1.00	63	71	2360	86	1390	0.35
13	230	50	1000	77	0.49	58	65	3390	0	1995	0.00
14	230	50	1000	86	0.55	56	63	3015	23	1775	0.09
15	230	50	1000	90	0.57	53	60	2455	45	1445	0.18
16	230	50	1000	91	0.58	59	66	1965	60	1160	0.24

U = Voltage · f = Frequency · n = Speed (rpm) · P_{ed} = Power consumption · I = Current draw · LpA_{in} = Sound pressure level intake side · LwA_{in} = Sound power level intake side
 q_v = Air flow · P_{fs} = Pressure increase

