

W3G400-CC22-51 ebmpapst Datasheet

sales@fansco.com

www.fansco.com

Nominal data

Type	W3G400-CC22-51	
Motor	M3G084-FA	
Phase		1~
Nominal voltage	VAC	230
Nominal voltage range	VAC	200 .. 277
Frequency	Hz	50/60
Type of data definition		ml
Speed	min ⁻¹	1630
Power input	W	400
Current draw	A	2.6
Max. back pressure	Pa	160
Min. ambient temperature	°C	-25
Max. ambient temperature	°C	60

ml = Max. load · me = Max. efficiency · fa = Running at free air · cs = Customer specs · cu = Customer unit
Subject to alterations

Data according to ErP directive

Installation category	A
Efficiency category	Static
Variable speed drive	Yes
Specific ratio*	1.00

* Specific ratio = $1 + p_b / 100\,000\text{ Pa}$

		Actual	Request 2013	Request 2015
Overall efficiency η_{es}	%	39.7	27.1	31.1
Efficiency grade N		48.6	36	40
Power input P_{ed}	kW	0.39		
Air flow q_v	m ³ /h	3605		
Pressure increase p_{fs}	Pa	142		
Speed n	min ⁻¹	1635		

Data definition with optimum efficiency. LU-124564
The ErP data is determined using a motor-impeller combination in a standardised measurement configuration.



Technical features

Mass	8.7 kg
Size	400 mm
Surface of rotor	Coated in black
Material of electronics housing	Die-cast aluminium
Material of blades	Press-fitted sheet steel blank, sprayed with PP plastic
Material of wall ring	Sheet steel, pre-galvanised and coated in black plastic
Material of guard grille	Steel, phosphated and coated in black plastic
Number of blades	5
Direction of air flow	"V"
Direction of rotation	Counter-clockwise, seen on rotor
Type of protection	IP 54
Insulation class	"B"
Humidity class	F3-1
Max. permissible ambient motor temp. (transp./ storage)	+80 °C
Min. permissible ambient motor temp. (transp./storage)	-40 °C
Mounting position	Shaft horizontal or rotor on bottom; rotor on top on request
Condensate discharge holes	Rotor-side
Operation mode	S1
Motor bearing	Ball bearing
Technical features	<ul style="list-style-type: none"> - Output 10 VDC, max. 1.1 mA - Alarm relay - Motor current limit - Soft start - Control input 0-10 VDC / PWM - Control interface with SELV potential safely disconnected from the mains - Over-temperature protected electronics / motor - Line undervoltage detection
EMC interference immunity	Acc. to EN 61000-6-2 (industrial environment)
EMC harmonics	Acc. to EN 61000-3-2/3
EMC interference emission	Acc. to EN 61000-6-3 (household environment)
Touch current acc. IEC 60990 (measuring network Fig. 4, TN system)	<= 3.5 mA
Motor protection	Thermal overload protector (TOP) wired internally
Cable exit	Variable
Protection class	I (if protective earth is connected by customer)
Product conforming to standard	EN 61800-5-1; CE
Approval	CCC; CSA C22.2 Nr.77; EAC; UL 2111

EC axial fan - HyBlade®

sickled blades (S series)

with full round nozzle, Automotive

Product drawing

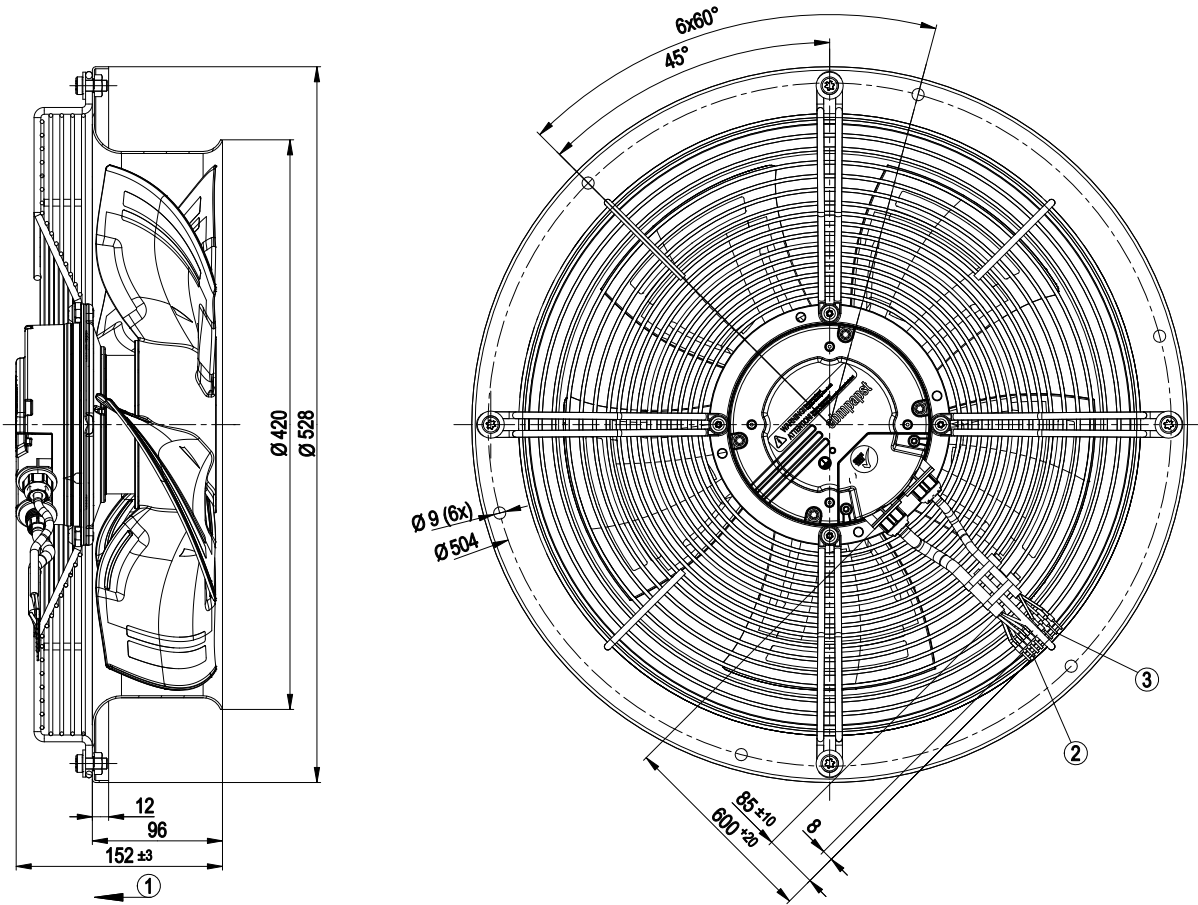

1	Direction of air flow "V"
2	Connection line PVC AWG18; 5x crimped core-end sleeves
3	Connection line PVC AWG22; 3x crimped core-end sleeves



Connection screen

Customer circuit

Notes on various control possibilities and their applications

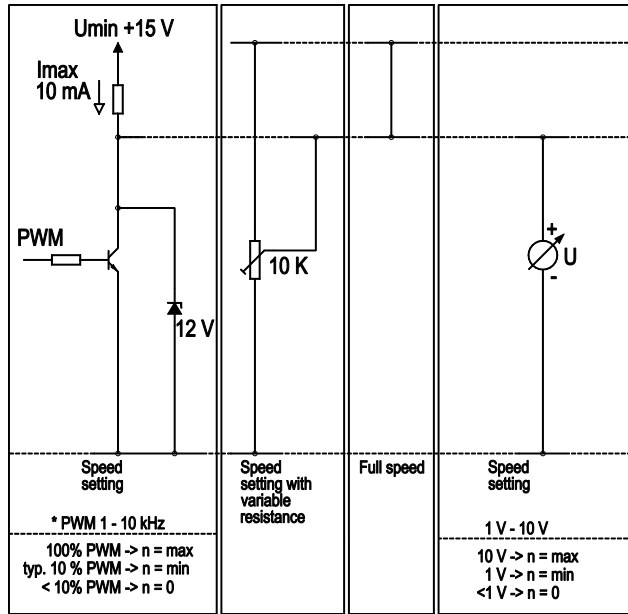

Connection

Fan / motor

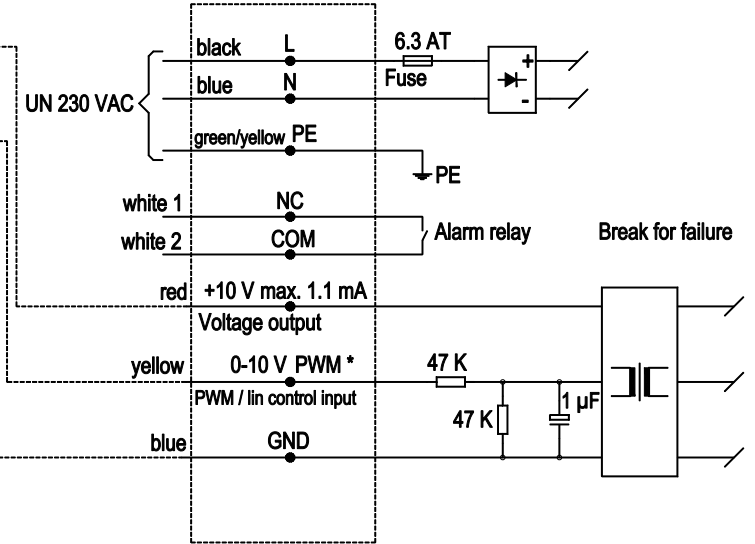

Charts: Air flow 50 Hz

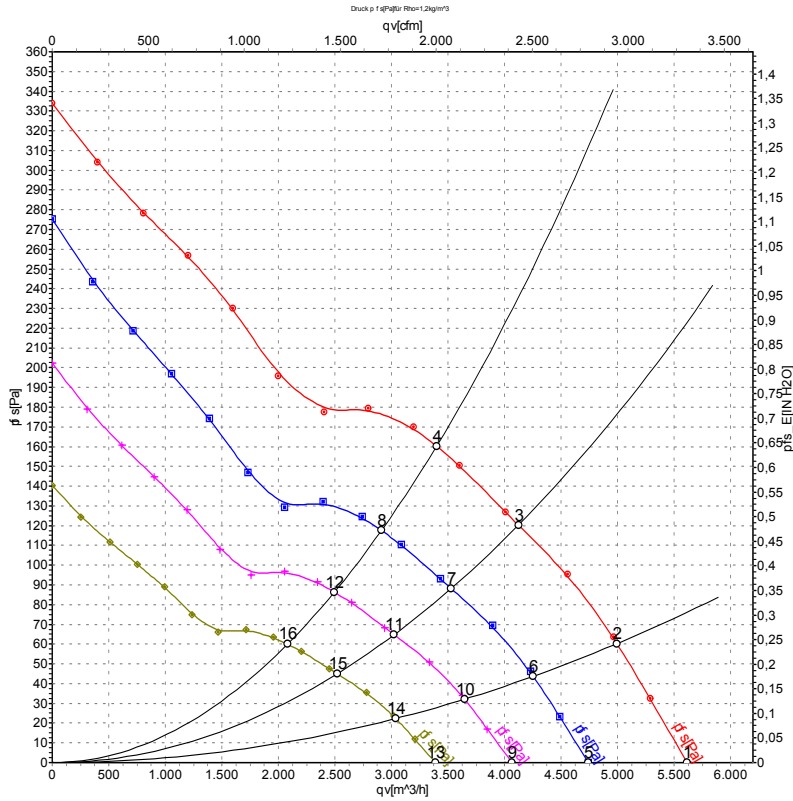

Air performance measured as per ISO 5801 Installation category A. For detailed information on the measuring set-up, please contact ebmpapst. Suction-side noise levels: LwA measured as per ISO 13347 / LpA measured with 1m distance to fan axis. The values given are valid under the measuring conditions mentioned above and may vary according to the actual installation situation. With any deviation from the standard set-up, the specific values have to be checked and reviewed with the unit installed.

Measured values

	U	f	n	P _{ed}	I	LpA _{in}	LwA _{in}	qv	ps
	V	Hz	min ⁻¹	W	A	dB(A)	dB(A)	m ³ /h	Pa
1	230	50	1660	350	2.24	71	78	5620	0
2	230	50	1645	380	2.43	69	76	4995	60
3	230	50	1635	391	2.50	66	72	4125	120
4	230	50	1630	400	2.60	67	74	3400	160
5	230	50	1400	211	1.35	67	74	4745	0
6	230	50	1400	235	1.50	65	72	4255	44
7	230	50	1400	245	1.56	63	69	3530	88
8	230	50	1400	249	1.59	64	71	2915	118
9	230	50	1200	133	0.85	64	70	4065	0
10	230	50	1200	148	0.95	62	69	3645	32
11	230	50	1200	154	0.99	59	66	3025	65
12	230	50	1200	157	1.00	61	68	2495	86
13	230	50	1000	77	0.49	60	67	3390	0
14	230	50	1000	86	0.55	58	65	3040	23
15	230	50	1000	89	0.57	55	62	2520	45
16	230	50	1000	91	0.58	57	64	2080	60

U = Supply voltage · f = Frequency · n = Speed · P_{ed} = Power input · I = Current draw · LpA_{in} = Sound pressure level inlet side · LwA_{in} = Sound power level inlet side · qv = Air flow
 ps = Pressure increase

