

EC axial fan

sickled blades (S series), single inlet

Wall ring with guard grille

W3G350-TN01-30 ebmpapst Datasheet

sales@fansco.com

www.fansco.com

Nominal data

Type	W3G350-TN01-30	
Motor	M3G074-CF	
Phase		1~
Nominal voltage	VAC	230
Nominal voltage range	VAC	200 .. 240
Frequency	Hz	50/60
Type of data definition		ml
Speed	min ⁻¹	1475
Power input	W	165
Current draw	A	1.35
Max. back pressure	Pa	100
Min. ambient temperature	°C	-40
Max. ambient temperature	°C	40

ml = Max. load · me = Max. efficiency · fa = Running at free air · cs = Customer specs · cu = Customer unit
Subject to alterations

Data according to ErP directive

Installation category	A
Efficiency category	Static
Variable speed drive	Yes
Specific ratio*	1.00

* Specific ratio = $1 + p_g / 100\,000\text{ Pa}$

		Actual	Request 2015
Overall efficiency η_{es}	%	40.7	28.6
Efficiency grade N		52.1	40
Power input P_{ed}	kW	0.16	
Air flow q_v	m ³ /h	2405	
Pressure increase p_{fs}	Pa	90	
Speed n	min ⁻¹	1500	

Data definition with optimum efficiency. LU-152182
The ErP data is determined using a motor-impeller combination in a standardised measurement configuration.



EC axial fan

sickled blades (S series), single inlet

Wall ring with guard grille

Technical features

Mass	3.8 kg
Size	350 mm
Surface of rotor	Thick layer passivated
Material of blades	Press-fitted sheet steel blank, sprayed with PP plastic
Material of wall ring	PP plastic
Material of guard grille	Steel, coated in black plastic (RAL9005)
Number of blades	5
Direction of air flow	"V"
Direction of rotation	Counter-clockwise, seen on rotor
Type of protection	IP 54
Insulation class	"B"
Humidity class	F3-1
Max. permissible ambient motor temp. (transp./ storage)	+ 70 °C
Min. permissible ambient motor temp. (transp./storage)	- 40 °C
Mounting position	Any
Condensate discharge holes	None, open rotor
Cooling bore / aperture	Rotor-side
Operation mode	S1
Motor bearing	Ball bearing with anti-freezing grease
Technical features	<ul style="list-style-type: none"> - Speed adjustment input (230 V) - Output limit - Motor current limit - Soft start - Overvoltage detection - Over-temperature protected electronics / motor - Line undervoltage detection
Speed steps	2
Touch current acc. IEC 60990 (measuring network Fig. 4, TN system)	<= 3.5 mA
Cable exit	Variable
Protection class	I (if protective earth is connected by customer)
Product conforming to standard	EN 60335-1; CE
Approval	CCC



EC axial fan

sickled blades (S series), single inlet

Wall ring with guard grille

Product drawing

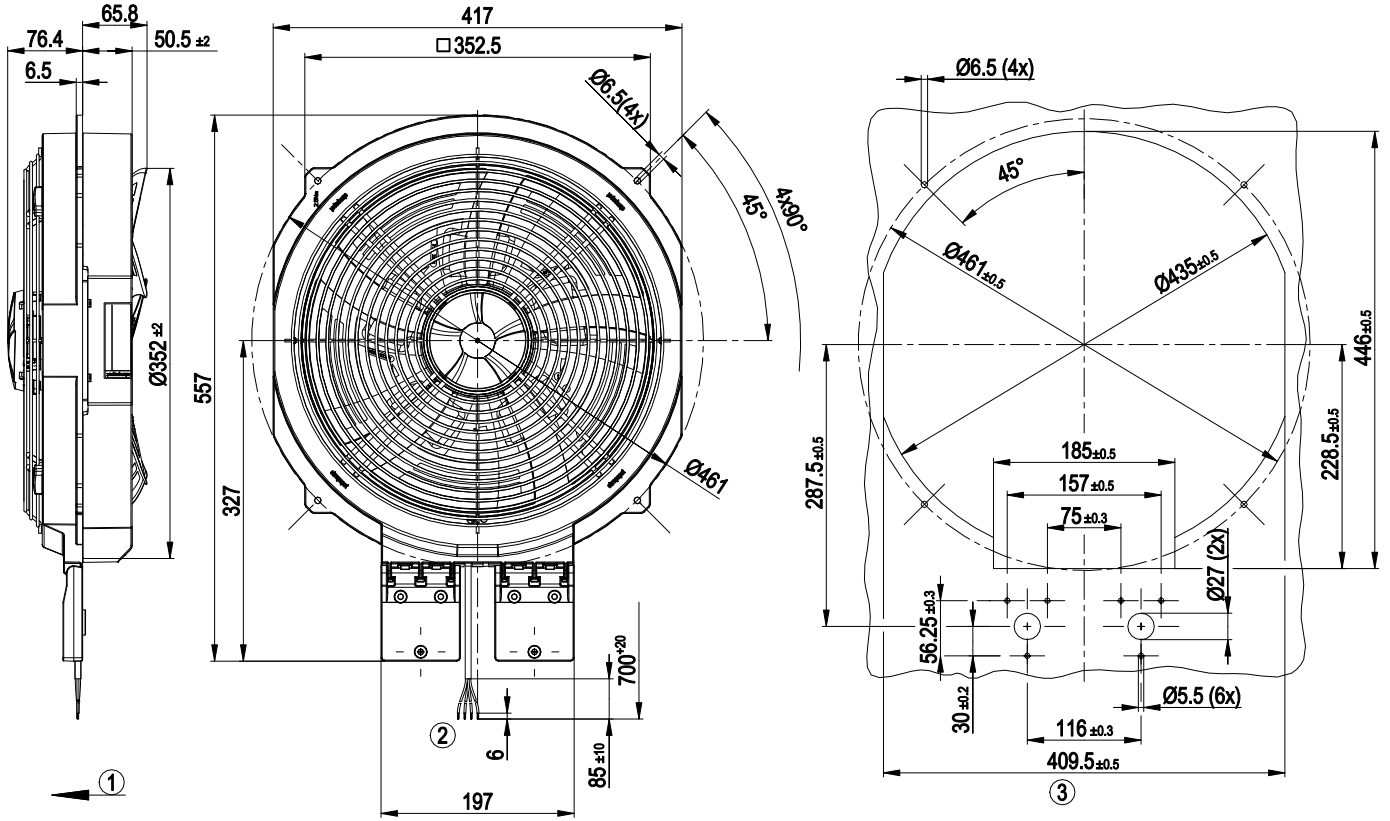

1	Direction of air flow "V"
2	Connection line PVC 4G 0.5 mm ² , 4x lead tips crimped
3	Mounting dimensions



EC axial fan

sickled blades (S series), single inlet

Wall ring with guard grille

Connection screen

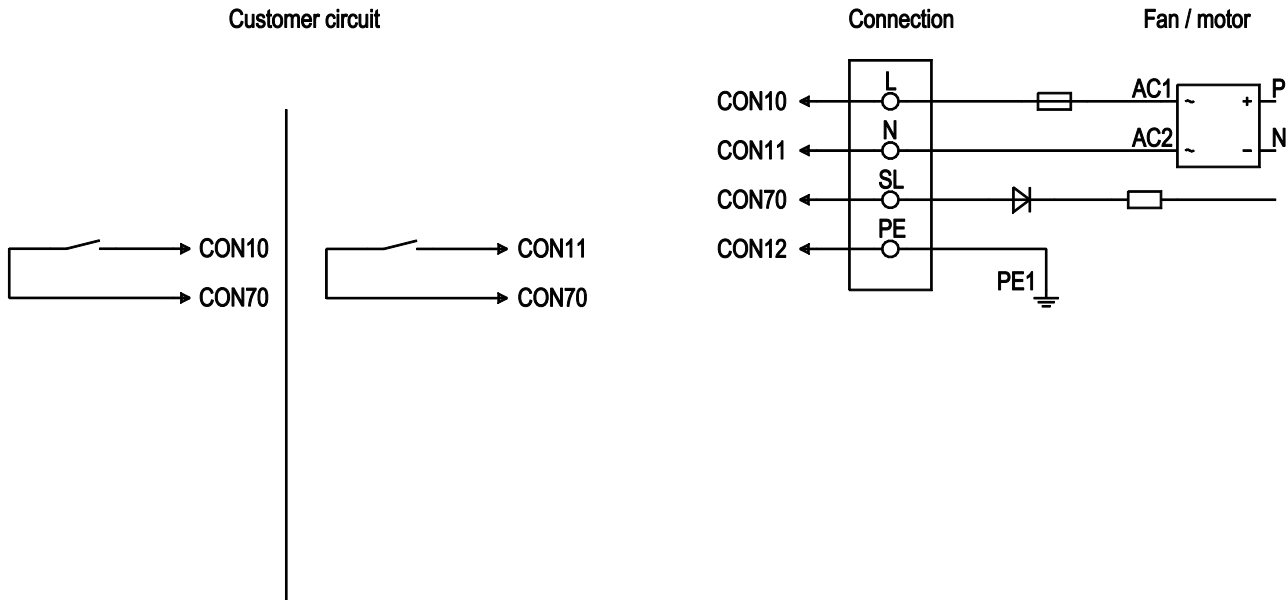

No.	Conn.	Designation	Colour	Function / assignment
	CON 10	L	black	Power supply 230 VAC, 50 - 60 Hz, see type plate for voltage range
	CON 11	N	blue	Neutral conductor
	CON 12	PE	green/yellow	Protective earth
	CON 70	SL	brown	Speed selection: switch open = speed 1; switch closed = speed 2



EC axial fan

sickled blades (S series), single inlet

Wall ring with guard grille

Charts: Air flow 50 Hz

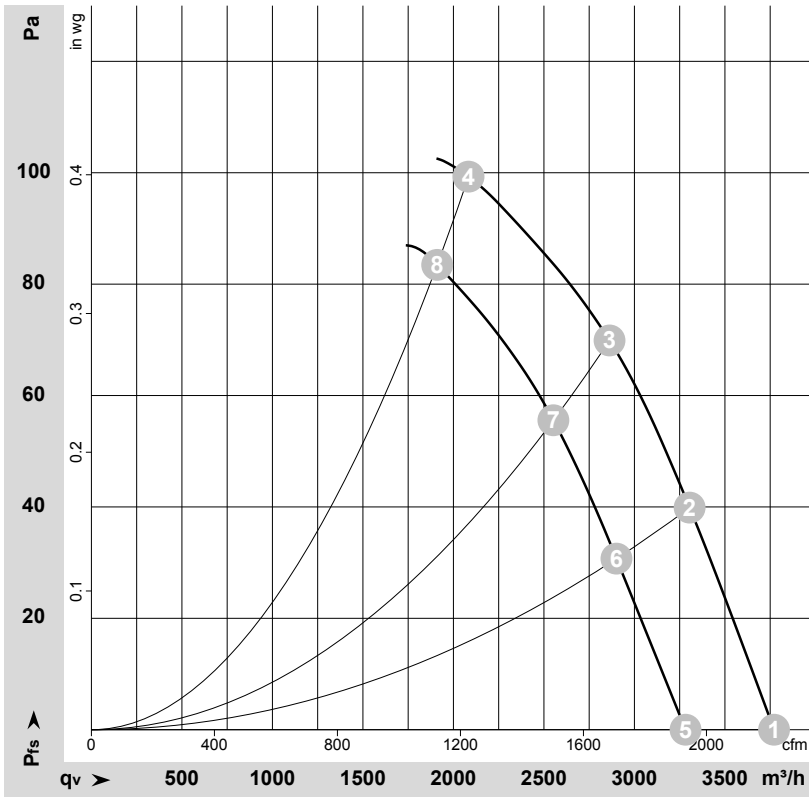

$\rho = 1,15 \text{ kg/m}^3 \pm 2\%$

Measurement: LU-152182
Measurement: LU-152184

Air performance measured as per ISO 5801 Installation category A. For detailed information on the measuring set-up, please contact ebm-papst. Suction-side noise levels: LwA measured as per ISO 13347 / LpA measured with 1m distance to fan axis. The values given are valid under the measuring conditions mentioned above and may vary according to the actual installation situation. With any deviation from the standard set-up, the specific values have to be checked and reviewed with the unit installed.

Measured values

	U	f	n	P _{ed}	I	LpA _{in}	LwA _{in}	qv	p _{fs}
	V	Hz	min ⁻¹	W	A	dB(A)	dB(A)	m ³ /h	Pa
1	230	50	1610	153	1.27	62	70	3770	0
2	230	50	1585	165	1.35	61	68	3305	40
3	230	50	1540	165	1.35	59	66	2860	70
4	230	50	1475	165	1.35	59	66	2085	100
5	230	50	1405	102	0.87	60	66	3280	0
6	230	50	1385	112	0.95	58	65	2900	31
7	230	50	1370	118	1.00	57	64	2550	56
8	230	50	1350	126	1.06	57	64	1910	83

U = Supply voltage · f = Frequency · n = Speed · P_{ed} = Power input · I = Current draw · LpA_{in} = Sound pressure level inlet side · LwA_{in} = Sound power level inlet side · qv = Air flow
p_{fs} = Pressure increase

