

W3G300-RQ28-56

EC axial fan

with brushless DC motor

Automotive



W3G300-RQ28-56 ebmpapst Datasheet FansCo

sales@fansco.com

www.fansco.com

Nominal data

Type	W3G300-RQ28-56	
Motor	M3G074-CF	
Nominal voltage	VDC	27.5
Nominal voltage range	VDC	16 .. 32
Method of obtaining data		fa
Speed (rpm)	min ⁻¹	3380
Power consumption	W	320
Current draw	A	11.5
Min. ambient temperature	°C	-40
Max. ambient temperature	°C	85

ml = Max. load · me = Max. efficiency · fa = Free air · cs = Customer specification · ce = Customer equipment
Subject to change

Data according to Commission Regulation (EU) 327/2011

		Actual	Req. 2015
01 Overall efficiency η_{es}	%	42.5	30.8
02 Measurement category		A	
03 Efficiency category		Static	
04 Efficiency grade N		51.7	40
05 Variable speed drive		Yes	

Data obtained at optimum efficiency level.
The ErP data is determined using a motor-impeller combination in a standardized measurement setup.

09 Power consumption P_e	kW	0.35
09 Air flow q_v	m ³ /h	1755
09 Pressure increase p_{fs}	Pa	277
10 Speed (rpm) n	min ⁻¹	3385
11 Specific ratio*		1.00

* Specific ratio = $1 + p_{fs} / 100\,000\text{ Pa}$

LU-122953



Technical description

Weight	2.5 kg
Fan size	300 mm
Impeller material	PBT plastic
Fan housing material	PP plastic
Number of blades	5
Airflow direction	"V"
Balancing grade according to DIN ISO 1940-1	G 10
Direction of rotation	Clockwise, viewed toward rotor
Degree of protection	IP24 KM
Insulation class	"B"
Moisture (F) / Environmental (H) protection class	F4-1
Max. permitted ambient temp. for motor (transport/storage)	+70 °C
Min. permitted ambient temp. for motor (transport/storage)	-40 °C
Installation position	Any
Condensation drainage holes	None, open rotor
Mode	S1
Motor bearing	Ball bearing; (sealed)
Life expectancy	25,000 h (typical)
Technical features	<ul style="list-style-type: none"> - Load dump protection - Motor current limitation - Soft start - Control input 0-5 VDC - Standstill on cable break - Overvoltage detection - Thermal overload protection for electronics - Line undervoltage detection - Reverse polarity protection
EMC regulations	According to ECE R10 Rev. 3
Electrical hookup	With plug; Standby current less than 500 µA
Motor protection	Reverse polarity and locked-rotor protection
With cable	Lateral
Approval	E1; EAC

Product drawing

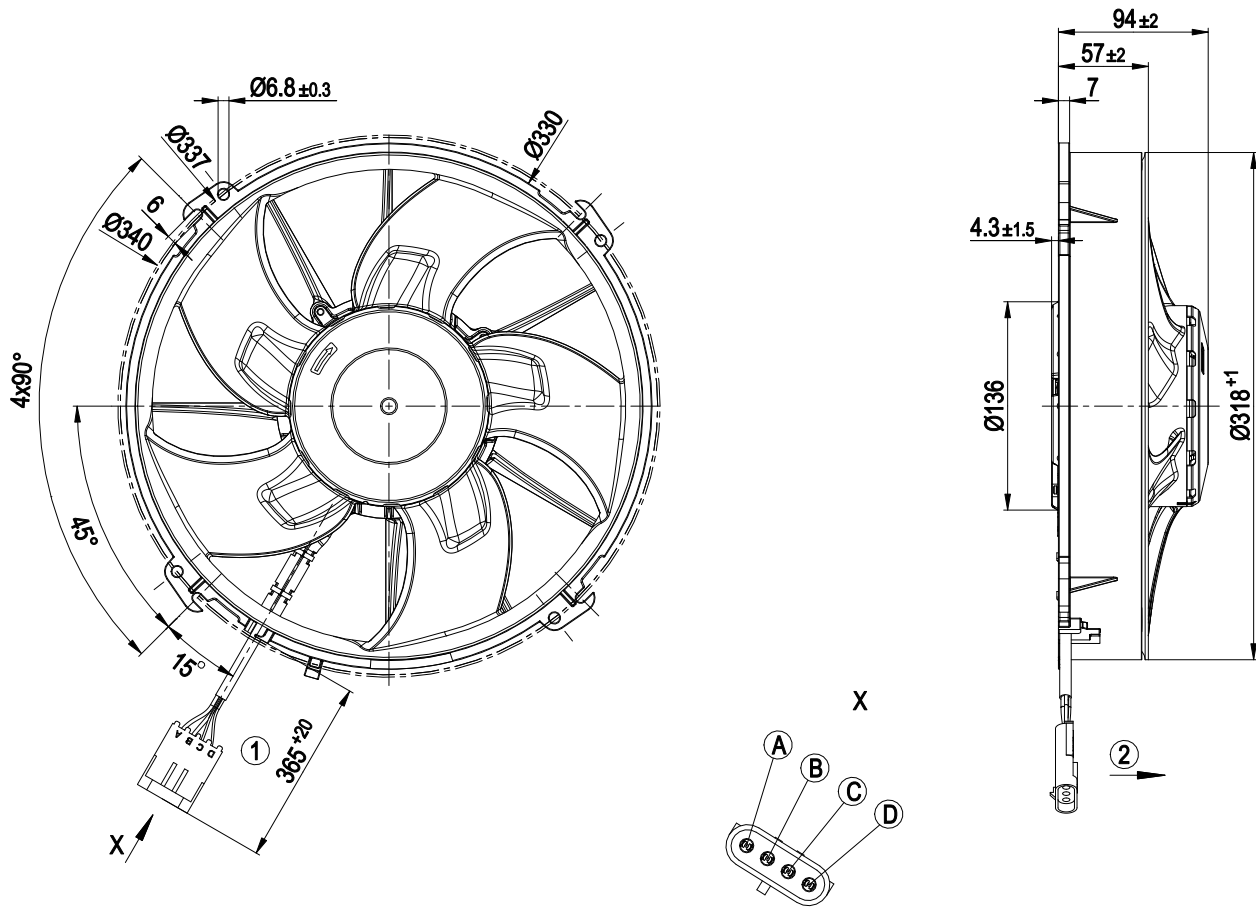

1 Cable with 4-pole coded plug Packard Electric 12010974

2 Direction of air flow "A"

A + UB (red)

B PWM/LIN (blue)

C CGND (white)

D GND (black)

Socket on customer circuit:

Housing: Packard 12015797

Plug contacts: Packard 120 89188 and Packard 121 24580

Seal: Packard 153 24982 and Packard 153 24983



EC axial fan

with brushless DC motor
Automotive

Connection diagram

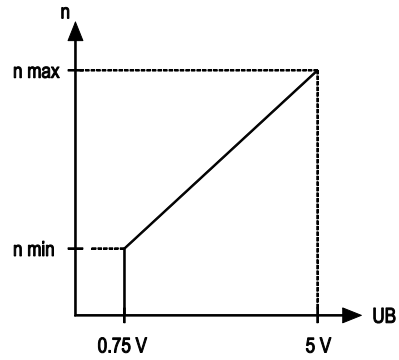
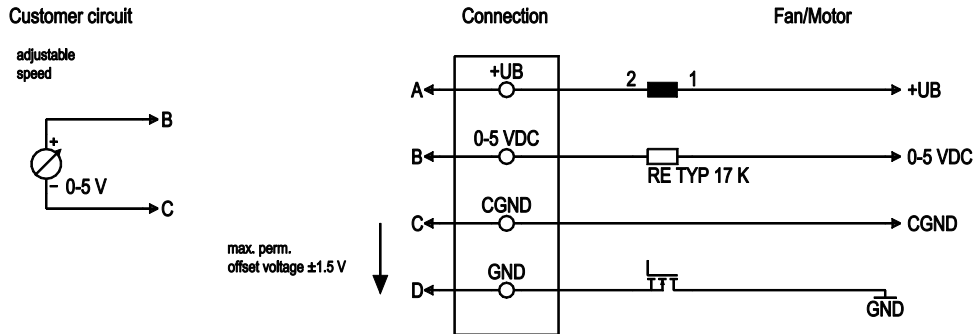

No.	Conn.	Designation	Function/assignment
	A	+UB	Power supply
	B	0-5 VDC	Analog voltage control input 0-5 V
	C	CGND	Control input reference ground, permissible offset ± 1.5 V
	D	GND	Power supply GND, reference ground



Curves: Air performance

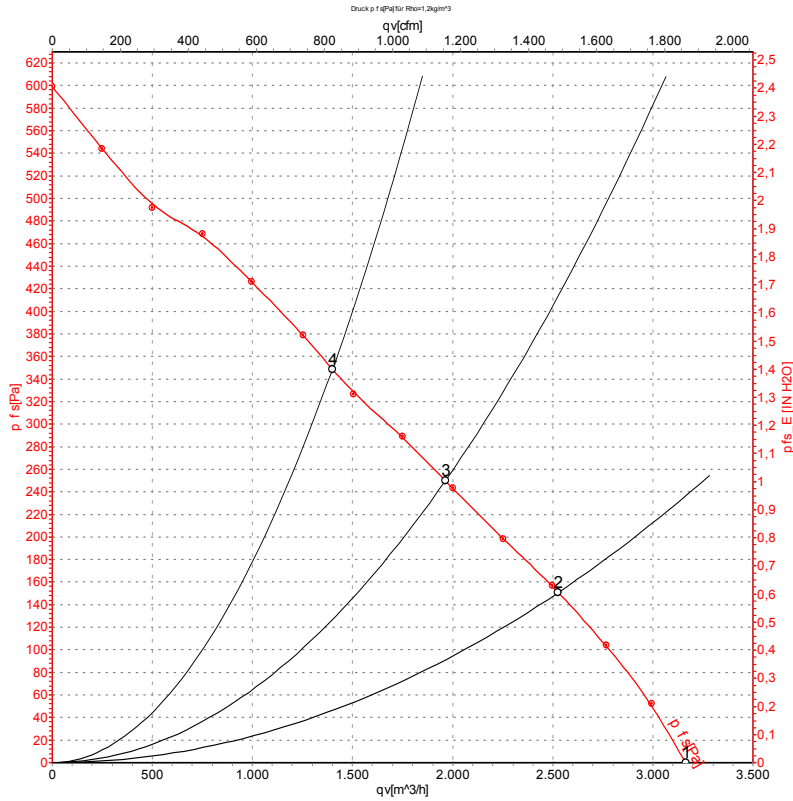

Measurement: LU-122953-1

Air performance measured according to ISO 5801 installation category A. For detailed information on the measurement setup, contact ebm-papst. Intake sound level: Sound power level according to ISO 13347 / sound pressure level measured at 1 m distance from fan axis. The values given are valid under the specified measuring conditions and may vary due to conditions of installation. For deviations from the standard configuration, the parameters have to be checked on the installed unit.

Measured values

	U	n	P _{ed}	I	LpA _{in}	q _v	P _{fs}	q _v	P _{fs}
	V	min ⁻¹	W	A	dB(A)	m ³ /h	Pa	cfm	in. wg
1	27.5	3380	320	11.50	76	3165	0	1860	0.00
2	27.5	3380	334	12.14	77	2525	150	1485	0.60
3	27.5	3380	344	12.46	79	1965	250	1155	1.00
4	27.5	3370	375	13.63	81	1400	350	825	1.41

U = Power supply · n = Speed (rpm) · P_{ed} = Power consumption · I = Current draw · LpA_{in} = Sound pressure level intake side · q_v = Air flow · P_{fs} = Pressure increase

