

EC axial fan

with brushless DC motor

W3G300-QX25-33 ebmpapst Datasheet
 sales@fansco.com
 www.fansco.com

Limited partnership · Headquarters Mulfingen
 Amtsgericht (court of registration) Stuttgart · HRA 590344
 General partner Elektrobau Mulfingen GmbH · Headquarters Mulfingen
 Amtsgericht (court of registration) Stuttgart · HRB 590142

Nominal data

Type	W3G300-QX25-33	
Motor	M3G084-BF	
Nominal voltage	VDC	26
Nominal voltage range	VDC	16 .. 32
Method of obtaining data		fa
Status		prelim.
Speed (rpm)	min ⁻¹	3800
Power consumption	W	400
Current draw	A	15.0
Min. ambient temperature	°C	-40
Max. ambient temperature	°C	85

ml = Max. load · me = Max. efficiency · fa = Free air · cs = Customer specification · ce = Customer equipment
 Subject to change

Data according to Commission Regulation (EU) 327/2011 (EN 17166)

		Actual	Req. 2015			
01 Overall efficiency η_{es}	%	50.4	31.6	09 Power consumption P_e	kW	0.46
02 Measurement category		A		09 Air flow q_v	m ³ /h	2050
03 Efficiency category		Static		09 Pressure increase p_{fs}	Pa	373
04 Efficiency grade N		58.8	40	10 Speed (rpm) n	min ⁻¹	3645
05 Variable speed drive		Yes		11 Specific ratio*		1.00

Data obtained at optimum efficiency level.

The ErP data is determined using a motor-impeller combination in a standardized measurement setup.

* Specific ratio = $1 + p_g / 100\,000\text{ Pa}$

LU-187429



Technical description

Weight	2.2 kg
Size	300 mm
Motor size	84
Impeller material	PA plastic
Fan housing material	PA plastic
Number of blades	7
Airflow direction	V
Balancing grade according to DIN ISO 1940-1	G 10
Direction of rotation	Clockwise, viewed toward rotor
Degree of protection	Motor IP24 KM, electronics IP6K9K (mating connector installed)
Insulation class	"B"
Moisture (F) / Environmental (H) protection class	H4
Ambient temperature note	Over +85 °C with power derating
Max. permitted ambient temp. for motor (transport/storage)	+85 °C
Min. permitted ambient temp. for motor (transport/storage)	-40 °C
Installation position	Any
Condensation drainage holes	None, open rotor
Mode	S1
Motor bearing	Ball bearing; (sealed)
Life expectancy	40,000 h (typical)
Technical features	<ul style="list-style-type: none"> - Error output (high-side switch) - Power limiter - Load dump (58 V) - Motor current limitation - Reverse operation (reversal of rotation) - Soft start - Control input 0-10 VDC / PWM - Temperature derating - Overvoltage detection - Thermal overload protection for electronics - Line undervoltage detection
Electrical hookup	Connector with cable; Standby current less than 500 µA
Motor protection	Reverse polarity and locked-rotor protection
With cable	Lateral
Approval	EAC



Product drawing

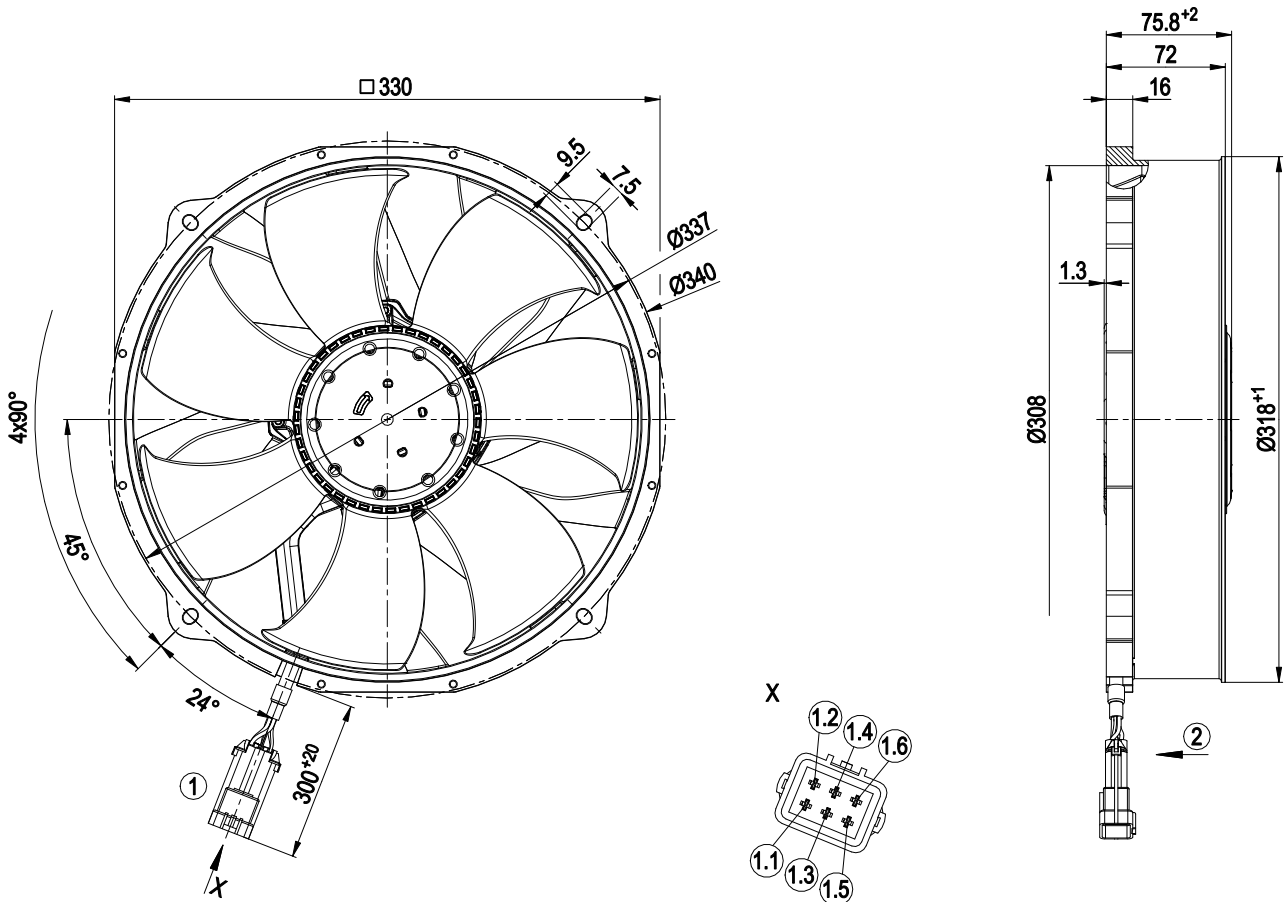

1	Cable FLRYW 2x 3 mm ² , 3x 0.75 mm ² 6-pole connector housing Delphi 12185126, 3x flat plug Delphi 12185129, 2x flat plug Delphi 12185237, 3x seal Delphi 15324974, 2x seal Delphi 15324976, 1x dummy plug Delphi 10730124, 1x locking cover Delphi 12185000
1.1	+ UB
1.2	GND
1.3	PWM/LIN
1.4	Not used / no function
1.5	Reverse
1.6	Diagnostic output
2	6-pole mating connector Delphi 15344052, 3x flat plug Delphi 12158098, 2x flat plug Delphi 12185008, 3x seal Delphi 15324974, 2x seal Delphi 15324976, 1x dummy plug Delphi 10730124, 1x locking cover Delphi 12185000
2	Airflow direction "V"



EC axial fan

with brushless DC motor

Connection diagram

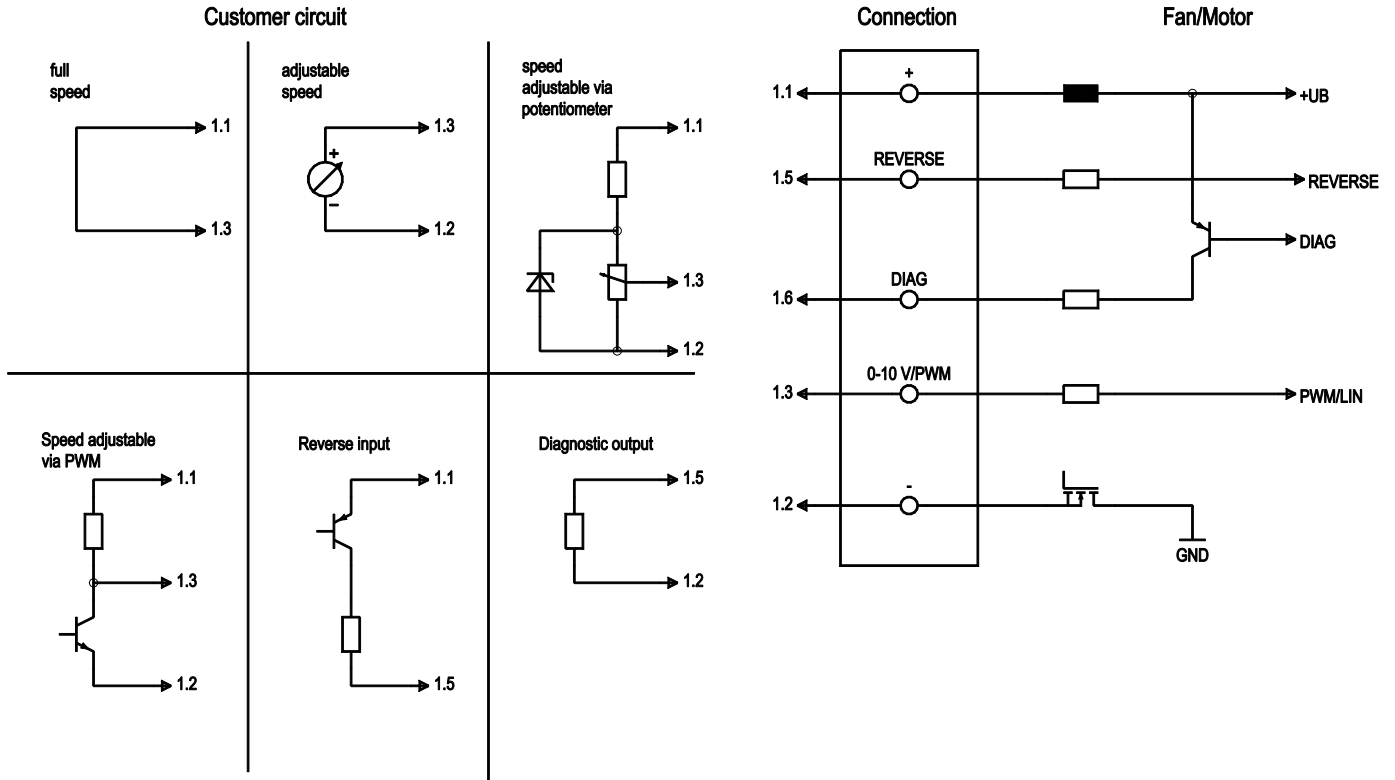

No.	Conn.	Designation	Color	Function/assignment
1	1.1	+UB	black	Power supply, see nameplate for voltage range
2	1.2	GND	brown	Power supply, see nameplate for voltage range
3	1.3	PWM/LIN	yellow	Control input: $R_i > 42\text{ k}\Omega$ 0-10 V (typ. $<1\text{ V} \rightarrow n = 0$; $1.5\text{ V} \rightarrow n = \text{min.}$; $10\text{ V} \rightarrow n = \text{max.}$), potentiometer (limit voltage at potentiometer with 12 V Z-diode) or PWM ($>12\text{ V}$; 10-50 kHz; typ. $<2\% \rightarrow n = 0$; $5\% \rightarrow n = \text{min.}$; $100\% \rightarrow n = \text{max.}$)
4	1.4	-	-	not used
5	1.5	Reverse	blue	Reversal of rotation input: $R_i = 47\text{ k}\Omega$ connected to power supply + \rightarrow direction of rotation is reversed, or open \rightarrow reversal of rotation inactive
6	1.6	DIAG	white	Diagnostic output: $R_i = 0.05\text{ k}\Omega$ output level in nominal operation \rightarrow Low



Curves: Air performance

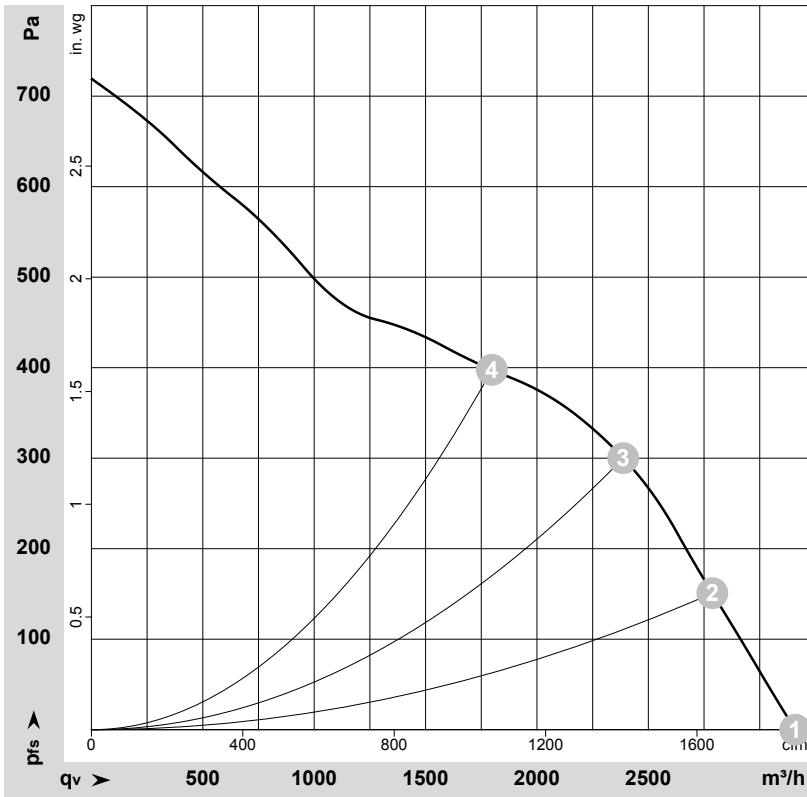

$\rho = 1.15 \text{ kg/m}^3 \pm 2 \%$

Measurement: LU-187429-1

Air performance measured according to ISO 5801 installation category A. For detailed information on the measurement setup, contact ebmpapst. Intake sound level: Sound power level according to ISO 13347 / sound pressure level measured at 1 m distance from fan axis. The values given are valid under the specified measuring conditions and may vary due to conditions of installation. For deviations from the standard configuration, the parameters have to be checked on the installed unit.

Measured values

	U	n	P _{ed}	I	LpA _{in}	LwA _{in}	q _v	p _{fs}	q _v	p _{fs}
	V	min ⁻¹	W	A	dB(A)	dB(A)	m ³ /h	Pa	cfm	in. wg
1	26	3800	400	15.00	80	88	3160	0	1860	0.00
2	26	3725	426	16.37	79	87	2785	150	1640	0.60
3	26	3700	465	17.89	79	87	2385	300	1405	1.20
4	26	3700	462	17.74	82	89	1800	400	1060	1.61

U = Voltage · n = Speed (rpm) · P_{ed} = Power consumption · I = Current draw · LpA_{in} = Sound pressure level intake side · LwA_{in} = Sound power level intake side · q_v = Air flow
 p_{fs} = Pressure increase

