

# EC axial fan

with brushless DC motor  
for railway applications



W3G300-BV24-81 ebmpapst Datasheet  
sales@fansco.com  
www.fansco.com

Limited partnership · Headquarters Muldingen  
County court Stuttgart · HRA 590344

General partner Elektrobau Muldingen GmbH · Headquarters Muldingen  
County court Stuttgart · HRB 590142



## Nominal data

Type	W3G300-BV24-81	
Motor	M3G084-BF	
Nominal voltage	VDC	26
Nominal voltage range	VDC	16 .. 32
Type of data definition		fa
Speed	min <sup>-1</sup>	3160
Power input	W	205
Current draw	A	7.9
Min. ambient temperature	°C	-40
Max. ambient temperature	°C	95/110
Starting current	A	10

ml = Max. load · me = Max. efficiency · fa = Running at free air · cs = Customer specs · cu = Customer unit  
Subject to alterations

## Data according to ErP directive

Installation category	A
Efficiency category	Static
Variable speed drive	Yes
Specific ratio*	1.00

\* Specific ratio =  $1 + p_{fs} / 100\,000\text{ Pa}$

		Actual	Request 2013	Request 2015
Overall efficiency $\eta_{es}$	%	46.1	25.8	29.8
Efficiency grade N		56.3	36	40
Power input $P_e$	kW	0.24		
Air flow $q_v$	m <sup>3</sup> /h	1805		
Pressure increase $p_{fs}$	Pa	197		
Speed n	min <sup>-1</sup>	3040		

Data definition with optimum efficiency. LU-141130  
The ErP data is determined using a motor-impeller combination in a standardised measurement configuration.



## Technical features

Mass	2 kg
Size	300 mm
Material of blades	PA UL94 V0 plastic
Material of wall ring	PA UL94 V0 plastic
Number of blades	7
Direction of air flow	"V"
Balance quality according to DIN ISO 1940-1	G 10
Direction of rotation	Clockwise, seen on rotor
Type of protection	IP 24 KM; (motor); electronics IP 6K9K
Insulation class	"B"
Humidity class	F4-1
Note ambient temperature	Over +95 °C with power derating
Max. permissible ambient motor temp. (transp./ storage)	+110 °C
Min. permissible ambient motor temp. (transp./storage)	-40 °C
Mounting position	Any
Condensate discharge holes	None, open rotor
Operation mode	S1
Motor bearing	Ball bearing; (sealed)
Life expectancies	40,000 h (typical)
Technical features	<ul style="list-style-type: none"> <li>- Lowering input</li> <li>- Fault output (high-side switch max. 30 mA)</li> <li>- INVLIN (control input, inverse linear)</li> <li>- Output limit</li> <li>- Load dump (58 V)</li> <li>- Motor current limit</li> <li>- Soft start</li> <li>- Control input 0-10 VDC / PWM</li> <li>- Temperature derating</li> <li>- Overvoltage detection</li> <li>- Over-temperature protected electronics</li> <li>- Line undervoltage detection</li> </ul>
EMC directives	According to ECE R10 Rev. 3
Electrical leads	With plug; Standby current less than 500 µA
Motor protection	Reverse polarity and locked-rotor protection
Cable exit	Lateral
Protection class	III
Product conforming to standard	EN 61373, Cat. 1B: 2010
Approval	EAC; E1
Remark	According to EN 45545; EMC regulation: EN 50121-3-2 in preparation

# EC axial fan

with brushless DC motor  
for railway applications

Product drawing

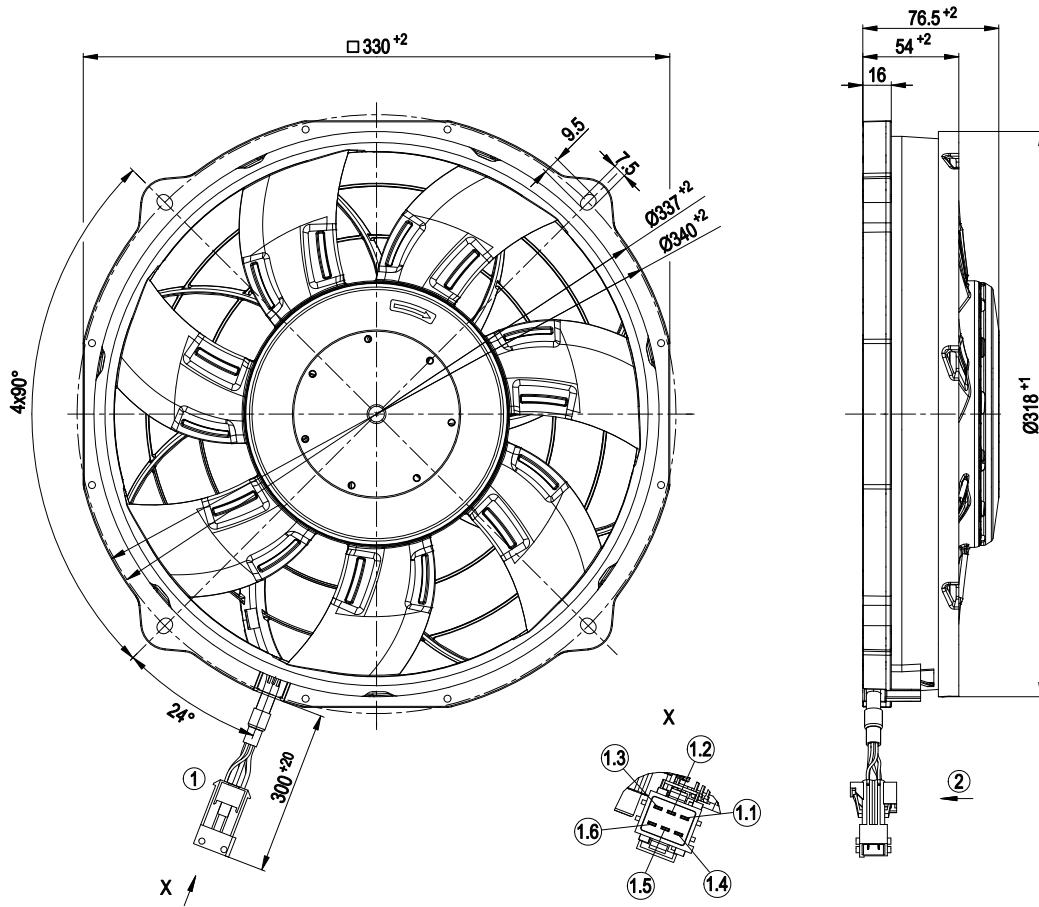

1	Connection line with plug Tyco Junior Power Timer 1-962349-1, 6-pole, coded Mating connector Tyco 1-963212-1 not included in scope of delivery
1.1	+ UB (black)
1.2	GND (brown)
1.3	PWM/LIN (yellow)
1.4	INVLIN (orange)
1.5	ABSENK (blue)
1.6	Diagnostic output (white)
2	Direction of air flow "V"



# EC axial fan

with brushless DC motor  
for railway applications

## Connection screen

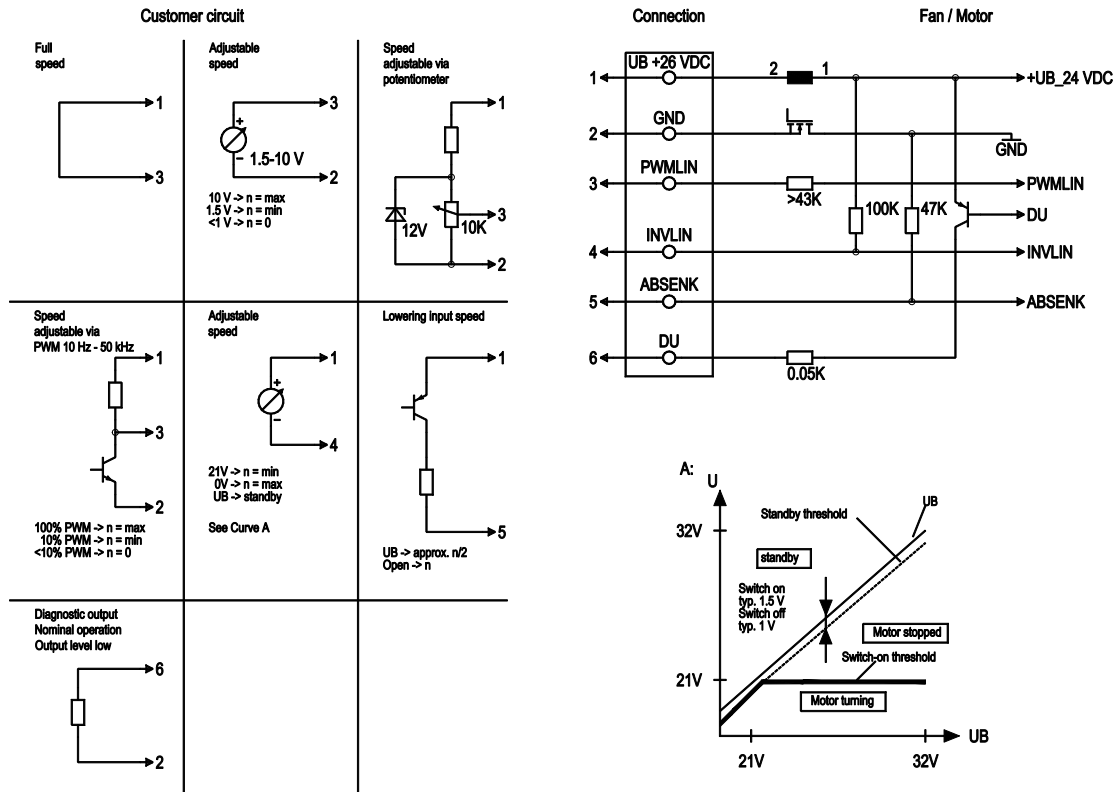

No.	Conn.	Designation	Function / assignment
	1	UB +26 VDC	Power supply 26 VDC
	2	GND	Power supply GND, reference ground
	3	PWMLIN	Analogue voltage control input 0 -10 V or PWM
	4	INVLIN	Control input, inverse linear
	5	ABSENK	Lowering input
	6	DU	Diagnostic output



## Charts: Air flow

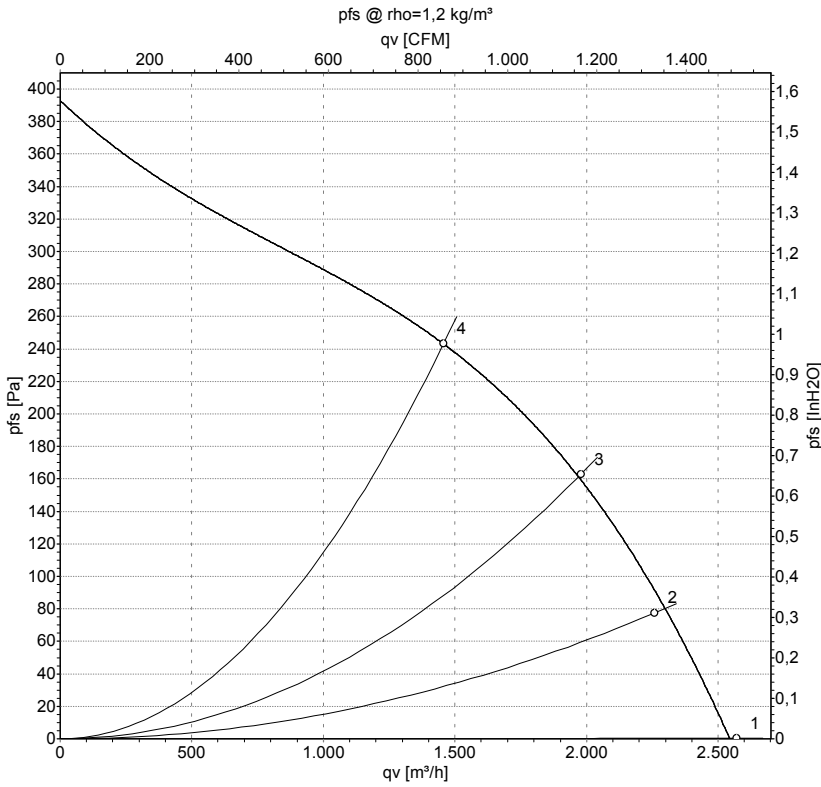

## Measured values

	U	n	P <sub>ed</sub>	I	LpA <sub>in</sub>	LwA <sub>in</sub>	qv	p <sub>fs</sub>
	V	min <sup>-1</sup>	W	A	dB(A)	dB(A)	m <sup>3</sup> /h	Pa
1	26	3160	205	7.90	74	82	2570	0
2	26	3155	216	8.32	73	82	2255	77
3	26	3085	240	9.24	73	81	1980	165
4	26	2965	244	9.36	73	80	1455	244

U = Supply voltage · n = Speed · P<sub>ed</sub> = Power input · I = Current draw · LpA<sub>in</sub> = Sound pressure level inlet side · LwA<sub>in</sub> = Sound power level inlet side · qv = Air flow · p<sub>fs</sub> = Pressure increase

