

W3G280-EQ20-43

# EC axial fan

with brushless DC motor

Automotive



W3G280-EQ20-43 ebmpapst Datasheet

sales@fansco.com

www.fansco.com

## Nominal data

Type	W3G280-EQ20-43	
Motor	M3G074-CF	
Nominal voltage	VDC	26
Method of obtaining data		fa
Speed (rpm)	min <sup>-1</sup>	3100
Power consumption	W	200
Current draw	A	7.5
Min. ambient temperature	°C	-40
Max. ambient temperature	°C	85

ml = Max. load · me = Max. efficiency · fa = Free air · cs = Customer specification · ce = Customer equipment  
Subject to change

## Data according to ErP Directive

		Actual	Req. 2015
01 Overall efficiency $\eta_{es}$	%	41	29.1
02 Measurement category		A	
03 Efficiency category		Static	
04 Efficiency grade N		51.9	40
05 Variable speed drive		Yes	

Data obtained at optimum efficiency level.  
The ErP data is determined using a motor-impeller combination in a standardized measurement setup.

09 Power consumption $P_e$	kW	0.19
09 Air flow $q_v$	m <sup>3</sup> /h	1355
09 Pressure increase $p_{fs}$	Pa	189
10 Speed (rpm) n	min <sup>-1</sup>	3085
11 Specific ratio*		1.00

\* Specific ratio =  $1 + p_{fs} / 100\,000\text{ Pa}$

LU-66886



## Technical description

Weight	2.4 kg
Fan size	280 mm
Impeller material	PBT plastic
Fan housing material	PP plastic
Number of blades	5
Airflow direction	"V"
Balancing grade according to DIN ISO 1940-1	G 10
Direction of rotation	Clockwise, viewed toward rotor
Degree of protection	IP24 KM
Insulation class	"B"
Moisture (F) / Environmental (H) protection class	F3-2
Max. permitted ambient temp. for motor (transport/storage)	+85 °C
Min. permitted ambient temp. for motor (transport/storage)	-40 °C
Installation position	Any
Condensation drainage holes	None, open rotor
Mode	S1
Motor bearing	Ball bearing; (sealed)
Life expectancy	25,000 h (typical)
Technical features	<ul style="list-style-type: none"> <li>- Lowering input</li> <li>- Tach output</li> <li>- Fault output (high-side switch max. 30 mA)</li> <li>- INVLIN (inverse linear control input)</li> <li>- Load dump (58 V)</li> <li>- Motor current limitation</li> <li>- Soft start</li> <li>- Control input 0-10 VDC / PWM</li> <li>- Overvoltage detection</li> <li>- Thermal overload protection for electronics</li> <li>- Line undervoltage detection</li> </ul>
EMC regulations	According to ECE R10 Rev. 3
Electrical hookup	With plug; Standby current less than 500 µA
Motor protection	Reverse polarity and locked-rotor protection
With cable	Lateral
Approval	EAC; E1
Sound level	79 dB(A), sound power level according to ISO 13347
Comment	Type approval number – 035492

Product drawing

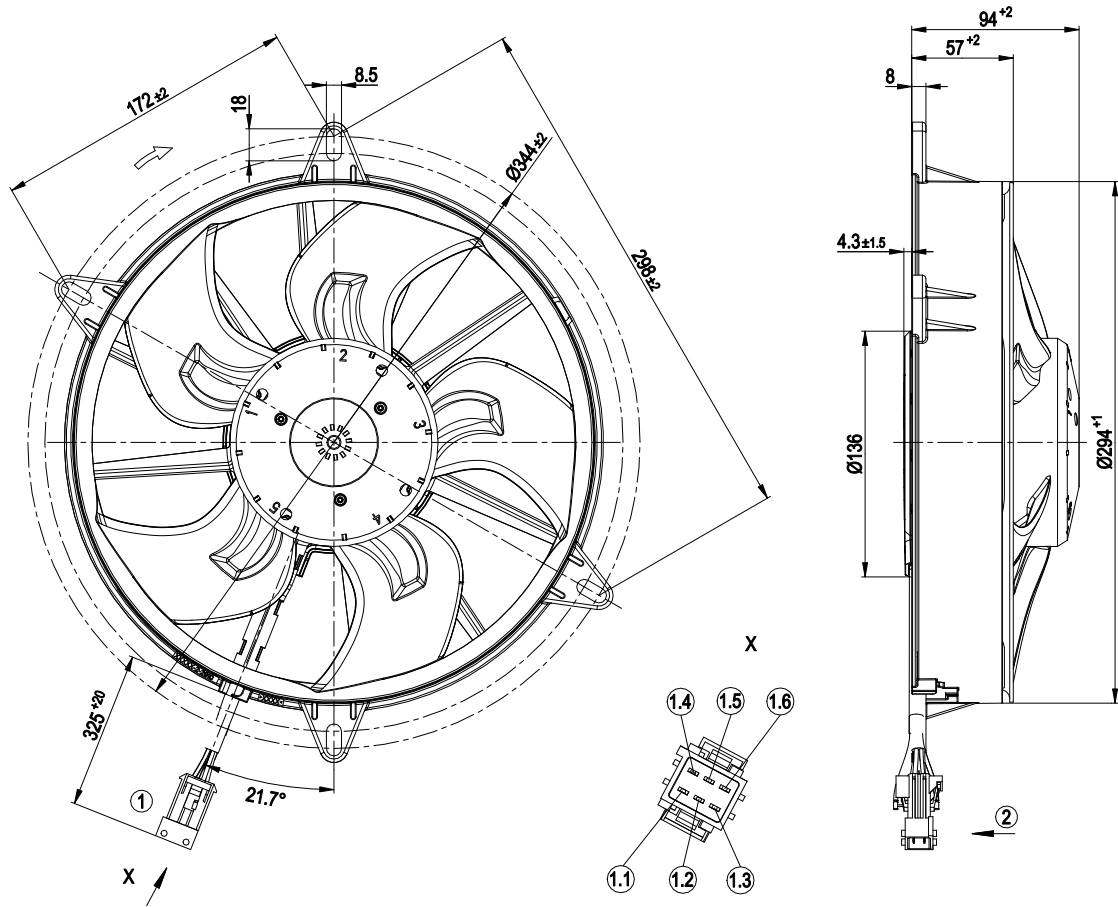

1	Cable with 6-pole coded plug tyco Junior Power Timer 1-962349-1 cable (460 mm) with mating connector, part no. 02002-4-1021 not included in scope of delivery
1.1	+ UB (black)
1.2	GND (brown)
1.3	PWM/LIN (yellow)
1.4	INVLIN (orange)
1.5	ABSENK (blue)
1.6	Diagnostic output (white)
2	Direction of air flow "V"

# EC axial fan

with brushless DC motor

Automotive

## Connection diagram

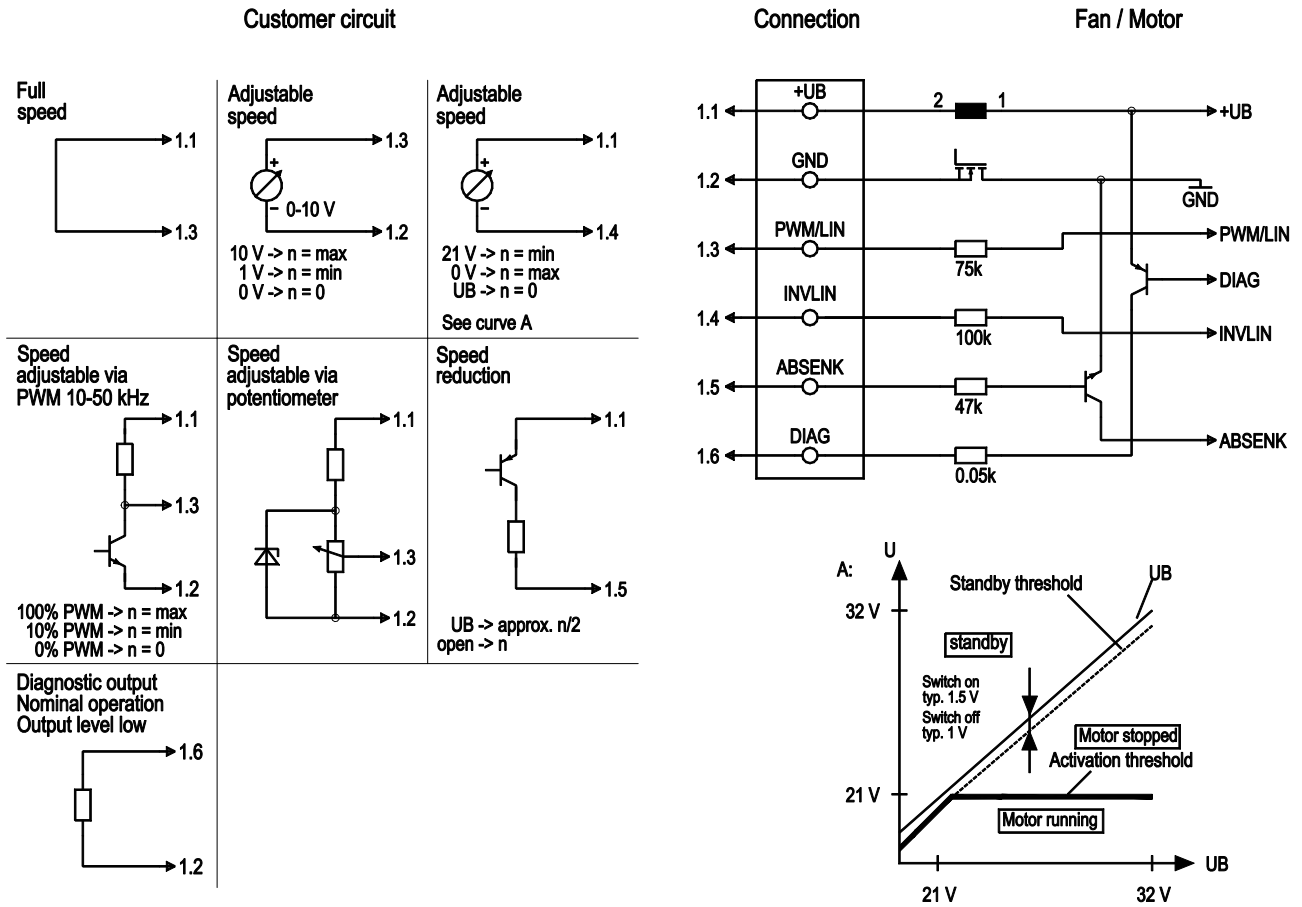

No.	Conn.	Designation	Function/assignment
1.1	+UB	Power supply	Power supply
1.2	GND	Power supply GND, reference ground	Power supply GND, reference ground
1.3	PWM/LIN	Analog voltage control input 0-10 V or PWM	Analog voltage control input 0-10 V or PWM
1.4	INVLIN	Control input, inverse linear	Control input, inverse linear
1.5	ABSENK	Lowering input	Lowering input
1.6	DIAG	Diagnostic output	Diagnostic output



## Curves: Air performance

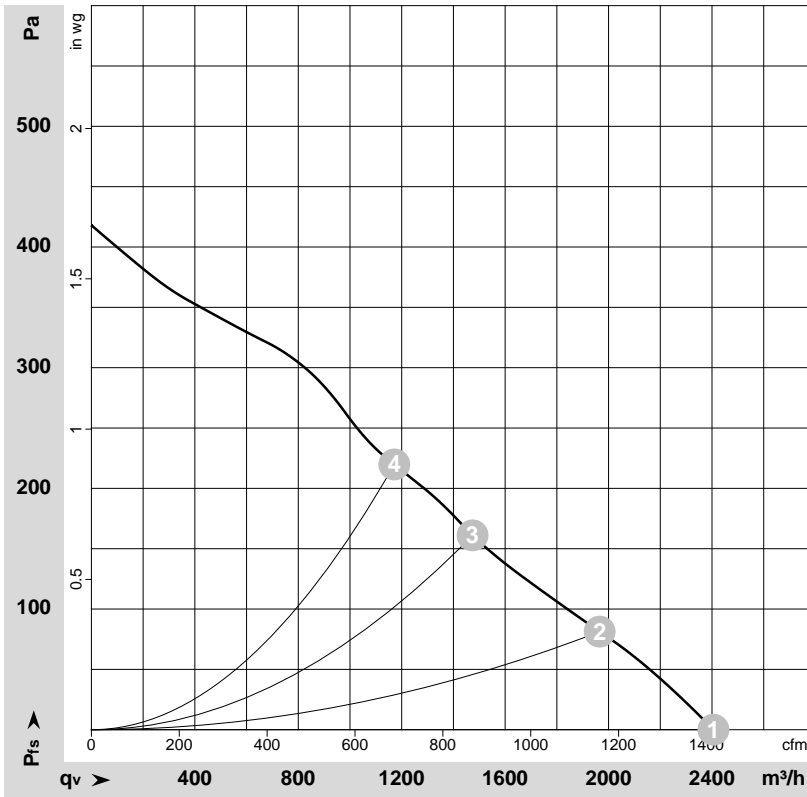

$\rho = 1.15 \text{ kg/m}^3 \pm 2 \%$

Measurement: LU-66886-1

Air performance measured according to ISO 5801 installation category A. For detailed information on the measurement setup, contact ebmpapst. Intake sound level: Sound power level according to ISO 13347 / sound pressure level measured at 1 m distance from fan axis. The values given are valid under the specified measuring conditions and may vary due to conditions of installation. For deviations from the standard configuration, the parameters have to be checked on the installed unit.

## Measured values

	U	n	P <sub>ed</sub>	I	qv	p <sub>fs</sub>	qv	p <sub>fs</sub>
	V	min <sup>-1</sup>	W	A	m <sup>3</sup> /h	Pa	CFM	inH <sub>2</sub> O
1	26	3100	200	7.50	2405	0	1415	0.00
2	26	3095	200	7.50	1965	80	1155	0.32
3	26	3085	192	7.35	1475	160	870	0.64
4	26	3105	214	8.22	1170	220	690	0.88

U = Power supply · n = Speed (rpm) · P<sub>ed</sub> = Power consumption · I = Current draw · qv = Air flow · p<sub>fs</sub> = Pressure increase

