

W3G200-HD01-03

EC axial compact fan - HyBlade

sickle-shaped blades (S series)



W3G200-HD01-03 ebmpapst Datasheet

sales@fansco.com

www.fansco.com

Nominal data

Type	W3G200-HD01-03	
Motor	M3G055-BD	
Phase		1~
Nominal voltage	VAC	230
Nominal voltage range	VAC	200 .. 240
Frequency	Hz	50/60
Method of obtaining data		ml
Speed (rpm)	min ⁻¹	2900
Power consumption	W	54
Current draw	A	0.55
Max. back pressure	Pa	96
Max. back pressure	in. wg	0.39
Min. ambient temperature	°C	-25
Max. ambient temperature	°C	60

ml = Max. load · me = Max. efficiency · fa = Free air · cs = Customer specification · ce = Customer equipment
Subject to change



Technical description

Weight	1.7 kg
Size	200 mm
Motor size	55
Rotor surface	Thick-film passivated
Blade material	Press-fitted sheet steel blank, sprayed with PP plastic
Number of blades	7
Airflow direction	V
Direction of rotation	Counterclockwise, viewed toward rotor
Degree of protection	IP54
Insulation class	"B"
Moisture (F) / Environmental (H) protection class	H1
Max. permitted ambient temp. for motor (transport/storage)	+ 80 °C
Min. permitted ambient temp. for motor (transport/storage)	- 40 °C
Installation position	Any
Condensation drainage holes	None, open rotor
Mode	S1
Motor bearing	Ball bearing
Technical features	<ul style="list-style-type: none"> - Output 10 VDC, max. 1.1 mA - Tach output - Power limiter - Motor current limitation - Soft start - Control input 0-10 VDC / PWM - Control interface with SELV potential safely disconnected from supply - Overvoltage detection - Thermal overload protection for electronics/motor - Line undervoltage detection
Touch current according to IEC 60990 (measuring circuit Fig. 4, TN system)	<= 3.5 mA
Electrical hookup	Terminal strip; Via terminal strip
Motor protection	Electronic motor protection
With cable	Variable
Protection class	I (with customer connection of protective earth)
Conformity with standards	EN 60335-1; CE
Approval	CSA C22.2 No. 77 + CAN/CSA-E60730-1; CCC; UL 1004-7 + 60730-1

Product drawing

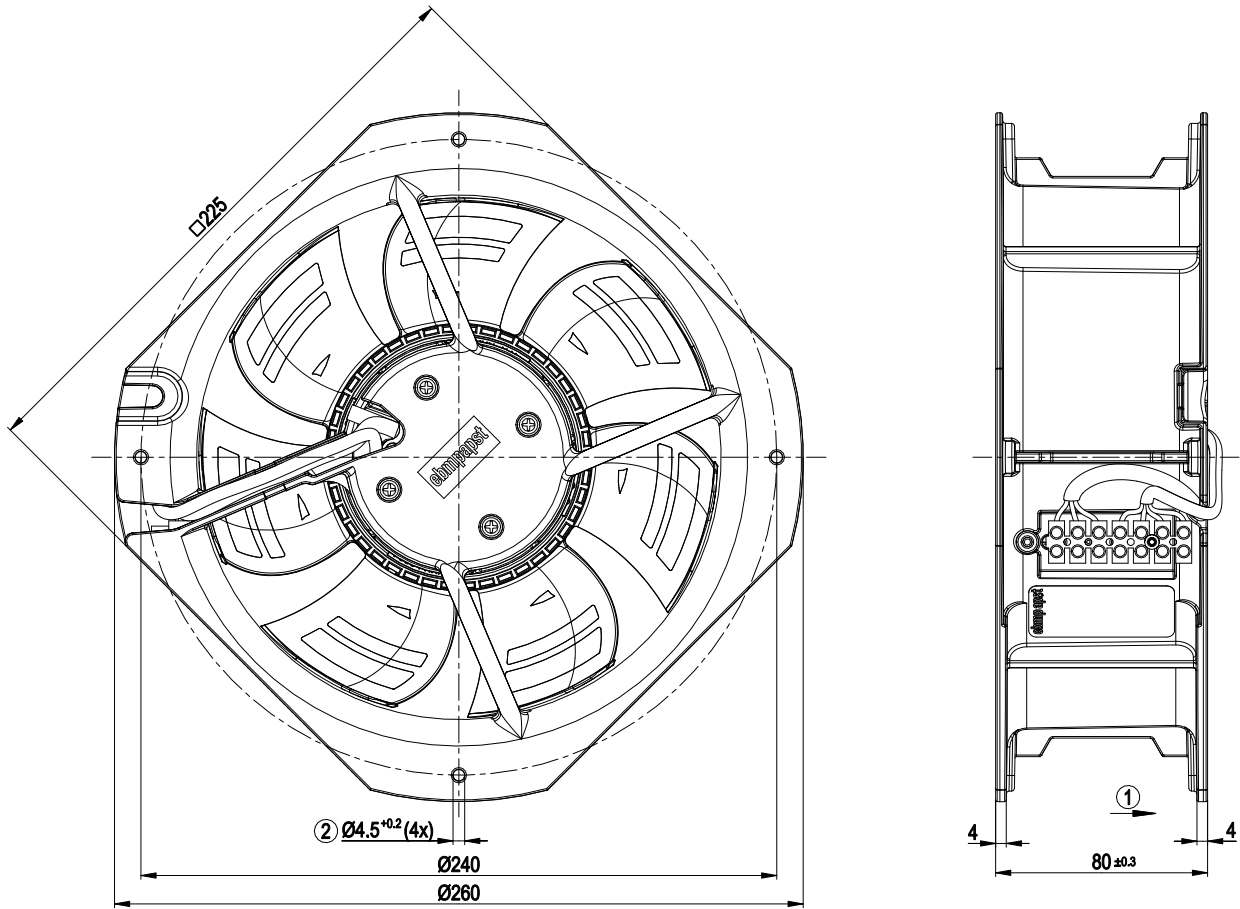

- 1 Direction of air flow "V"
- 2 For self-tapping M5 screws



Connection diagram

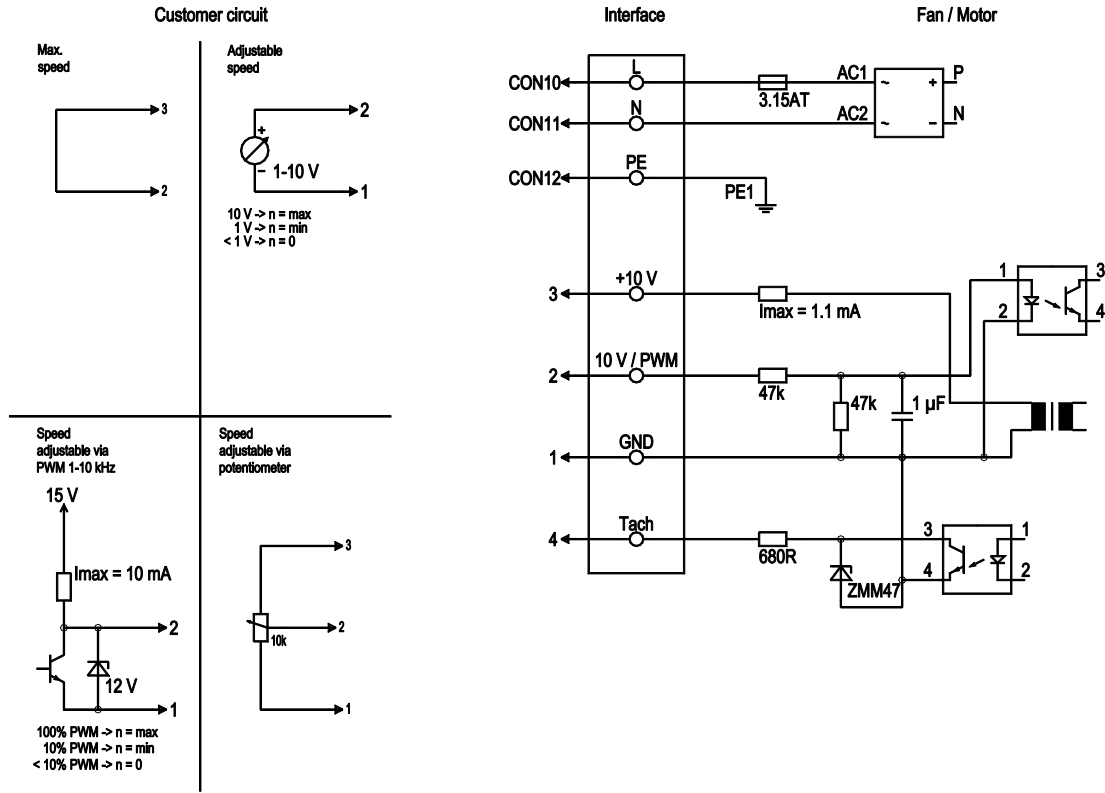

No.	Conn.	Designation	Color	Function/assignment
	CON10	L	black	Power supply 230 VAC, 50-60 Hz, see nameplate for voltage range
	CON11	N	blue	Neutral conductor
	CON12	PE	green/yellow	Protective earth
	1	GND	blue	GND connection for control interface
	2	0-10V PWM	yellow	Control input 0-10 V or PWM, electrically isolated
	3	10 V / max. 1,1 mA	red	Voltage output 10 VDC 1.1 mA, electrically isolated, short-circuit-proof
	4	Tacho	white	Tach output: open collector, 1 pulse per revolution, electrically isolated

Curves: Air performance 50 Hz

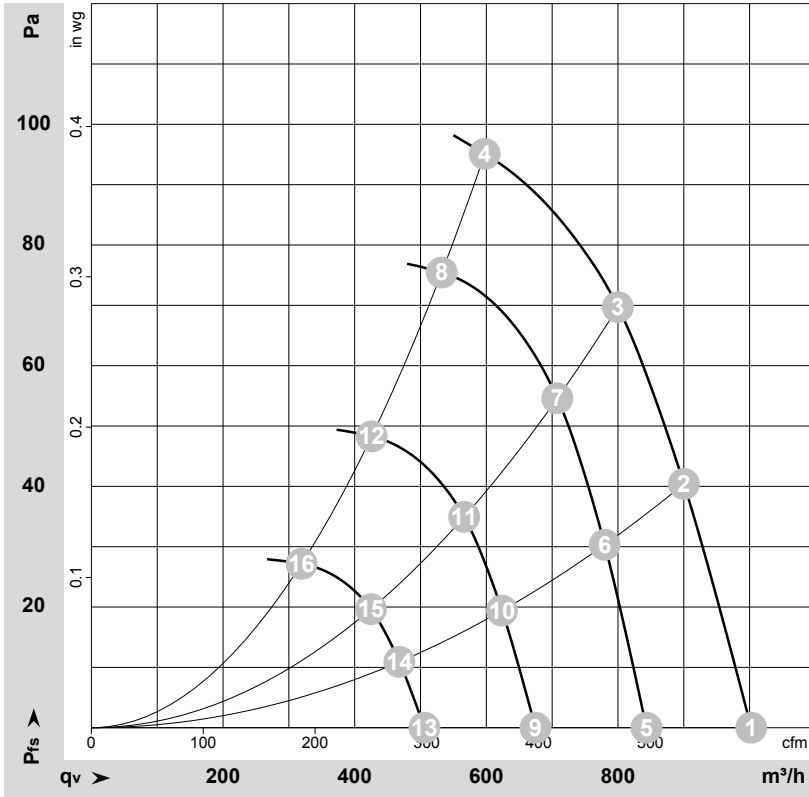

$\rho = 1.15 \text{ kg/m}^3 \pm 2 \%$

Measurement: LU-155339-1

Air performance measured according to ISO 5801 installation category A. For detailed information on the measurement setup, contact ebmpapst. Intake sound level: Sound power level according to ISO 13347 / sound pressure level measured at 1 m distance from fan axis. The values given are valid under the specified measuring conditions and may vary due to conditions of installation. For deviations from the standard configuration, the parameters have to be checked on the installed unit.

Measured values

	U	f	n	P _{ed}	I	LpA _{in}	LwA _{in}	q _v	P _{fs}	q _v	P _{fs}
	V	Hz	min ⁻¹	W	A	dB(A)	dB(A)	m ³ /h	Pa	cfm	in. wg
1	230	50	2970	50	0.49	58	65	1000	0	590	0.00
2	230	50	2885	55	0.53	57	64	900	40	530	0.16
3	230	50	2825	58	0.56	58	65	800	70	470	0.28
4	230	50	2900	54	0.55	64	71	600	96	350	0.39
5	230	50	2500	29	0.29	54	61	845	0	495	0.00
6	230	50	2500	35	0.35	53	61	780	30	460	0.12
7	230	50	2500	41	0.39	55	62	710	56	415	0.22
8	230	50	2500	40	0.39	61	68	530	75	315	0.30
9	230	50	2000	15	0.15	48	55	675	0	395	0.00
10	230	50	2000	18	0.18	48	55	625	19	365	0.08
11	230	50	2000	21	0.20	49	56	565	36	335	0.14
12	230	50	2000	20	0.20	55	63	425	48	250	0.19
13	230	50	1500	6.0	0.06	41	48	505	0	300	0.00
14	230	50	1500	8.0	0.07	41	48	470	11	275	0.04
15	230	50	1500	9.0	0.08	42	49	425	20	250	0.08
16	230	50	1500	9.0	0.08	48	55	320	27	190	0.11

U = Voltage · f = Frequency · n = Speed (rpm) · P_{ed} = Power consumption · I = Current draw · LpA_{in} = Sound pressure level intake side · LwA_{in} = Sound power level intake side
 q_v = Air flow · P_{fs} = Pressure increase

