

W2S130-AA13-87 ebmpapst Datasheet
 sales@fansco.com
 www.fansco.com

Nominal data

Type	W2S130-AA13-87		
Motor	M2S052-CA		
Phase		1~	1~
Nominal voltage	VAC	110	110
Frequency	Hz	50	60
Method of obtaining data		fa	fa
Valid for approval/standard		CE	CE
Speed (rpm)	min ⁻¹	2800	3250
Power consumption	W	47	42
Current draw	A	0.72	0.55
Min. ambient temperature	°C	-25	-25
Max. ambient temperature	°C	40	70

ml = Max. load · me = Max. efficiency · fa = Free air · cs = Customer specification · ce = Customer equipment
 Subject to change



Technical description

Weight	1.1 kg
Fan size	130 mm
Rotor surface	Rotor open, painted black
Blade material	Sheet steel, painted black
Fan housing material	Die-cast aluminum, painted black
Number of blades	7
Airflow direction	"V"
Direction of rotation	Counterclockwise, viewed toward rotor
Degree of protection	IP20
Insulation class	"B"
Max. permitted ambient temp. for motor (transport/storage)	+ 80 °C
Min. permitted ambient temp. for motor (transport/storage)	- 40 °C
Installation position	Any
Condensation drainage holes	None, open rotor
Mode	S1
Motor bearing	Ball bearing
Technical features	- Speed monitoring Hall IC (with basic insulation)
Touch current according to IEC 60990 (measuring circuit Fig. 4, TN system)	< 0.75 mA
Motor protection	Thermal overload protector (TOP) internally connected
Protection class	I (if protective earth is connected by customer to the housing's connection point)
Conformity with standards	EN 60335-1; CE
Approval	UL 507; CSA C22.2 No. 113

Product drawing

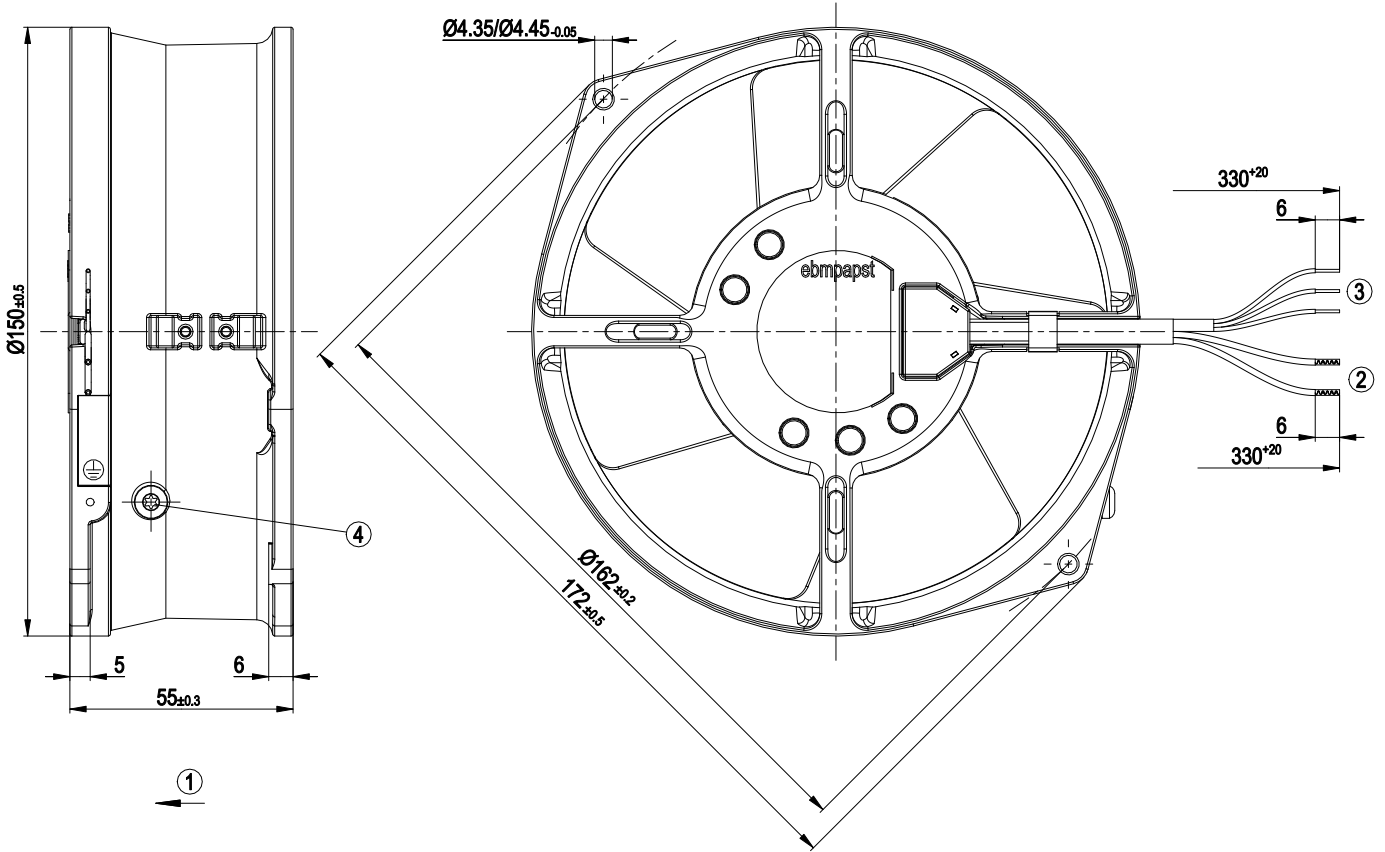

1	Direction of air flow "V"
2	Cable AWG 20, 2x crimped splices
3	Cable AWG 26, 3x tin-plated wire ends (6 mm)
4	M4 screw for fastening ground connector



Connection diagram

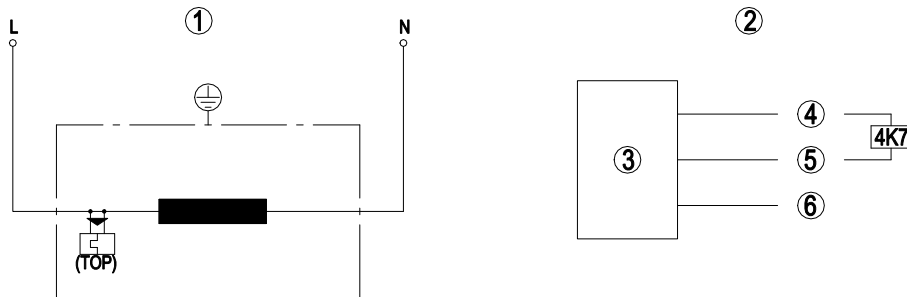

1	Fan connection diagram
TOP	Thermal overload protector
L	black
N	black
2	Hall IC circuit
3	Hall IC
4	red (+5 V)
5	white (out)
6	black (0 V)

Curves: Air performance 50 Hz

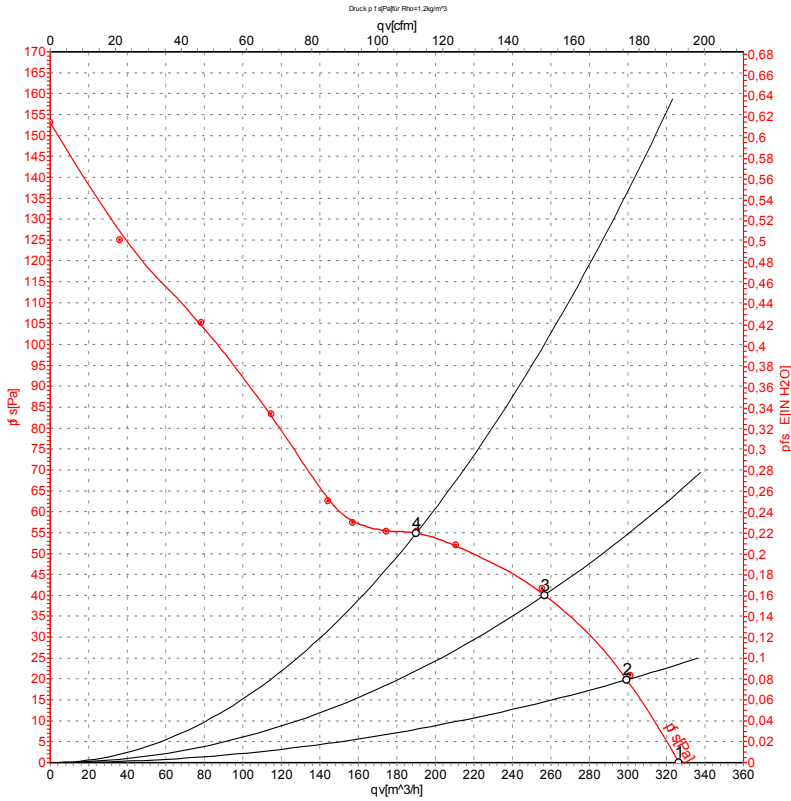

Measurement: LU-50883-1

Air performance measured according to ISO 5801 installation category A. For detailed information on the measurement setup, contact ebmpapst. Intake sound level: Sound power level according to ISO 13347 / sound pressure level measured at 1 m distance from fan axis. The values given are valid under the specified measuring conditions and may vary due to conditions of installation. For deviations from the standard configuration, the parameters have to be checked on the installed unit.

Measured values

	U	f	n	P _e	I	qv	p _{fs}	qv	p _{fs}
	V	Hz	min ⁻¹	W	A	m ³ /h	Pa	CFM	inH ₂ O
1	110	50	2800	47	0.72	325	0	190	0.00
2	110	50	2800	48	0.72	300	22	175	0.09
3	110	50	2785	49	0.73	255	41	150	0.16
4	110	50	2785	48	0.72	190	55	110	0.22

U = Power supply · f = Frequency · n = Speed (rpm) · P_e = Power consumption · I = Current draw · qv = Air flow · p_{fs} = Pressure increase



Curves: Air performance 60 Hz

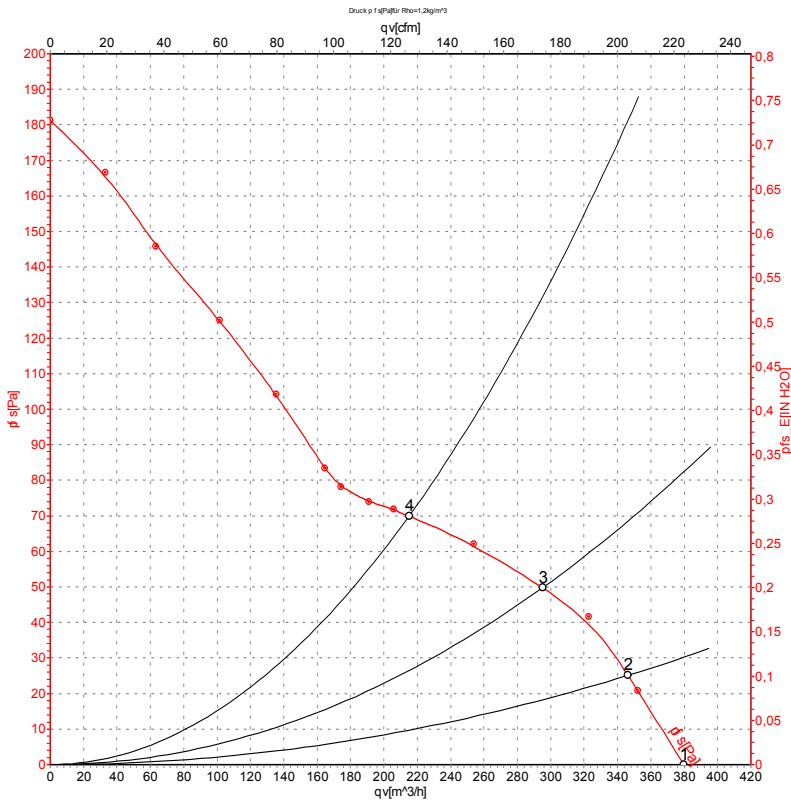

Measurement: LU-50884-1

Air performance measured according to ISO 5801 installation category A. For detailed information on the measurement setup, contact ebm-papst. Intake sound level: Sound power level according to ISO 13347 / sound pressure level measured at 1 m distance from fan axis. The values given are valid under the specified measuring conditions and may vary due to conditions of installation. For deviations from the standard configuration, the parameters have to be checked on the installed unit.

Measured values

	U	f	n	P _e	I	qv	p _{fs}	qv	p _{fs}
	V	Hz	min ⁻¹	W	A	m ³ /h	Pa	CFM	inH ₂ O
1	110	60	3250	42	0.55	380	0	225	0.00
2	110	60	3225	42	0.55	345	25	205	0.10
3	110	60	3200	44	0.57	295	50	175	0.20
4	110	60	3200	44	0.57	215	70	125	0.28

U = Power supply · f = Frequency · n = Speed (rpm) · P_e = Power consumption · I = Current draw · qv = Air flow · p_{fs} = Pressure increase

