

EC axial compact fan

sickle-shaped blades (S series), with brushless DC motor

W2G130-AA09-01 ebmpapst Datasheet

sales@fansco.com

www.fansco.com

Nominal data

Type	W2G130-AA09-01	
Motor	M2G055-BD	
Nominal voltage	VDC	48
Nominal voltage range	VDC	36 .. 56
Method of obtaining data		fa
Status		prelim.
Speed (rpm)	min ⁻¹	2950
Power consumption	W	14
Current draw	A	0.27
Max. ambient temperature	°C	60

ml = Max. load · me = Max. efficiency · fa = Free air · cs = Customer specification · ce = Customer equipment
Subject to change



Technical description

Weight	0.9 kg
Fan size	130 mm
Rotor surface	Painted black
Blade material	Sheet steel, painted black
Fan housing material	Die-cast aluminum, painted black
Number of blades	7
Airflow direction	"V"
Degree of protection	IP20
Moisture (F) / Environmental (H) protection class	H0 - dry environment
Max. permitted ambient temp. for motor (transport/storage)	+80 °C
Min. permitted ambient temp. for motor (transport/storage)	-40 °C
Installation position	Any
Condensation drainage holes	None
Mode	S1
Motor bearing	Ball bearing
Technical features	- Tach output
Motor protection	Reverse polarity and locked-rotor protection
Protection class	I (with customer connection of protective earth)
Conformity with standards	EN 60335-1
Approval	CSA C22.2 No. 113; UL 507; EAC

EC axial compact fan

sickle-shaped blades (S series), with brushless DC motor

Product drawing

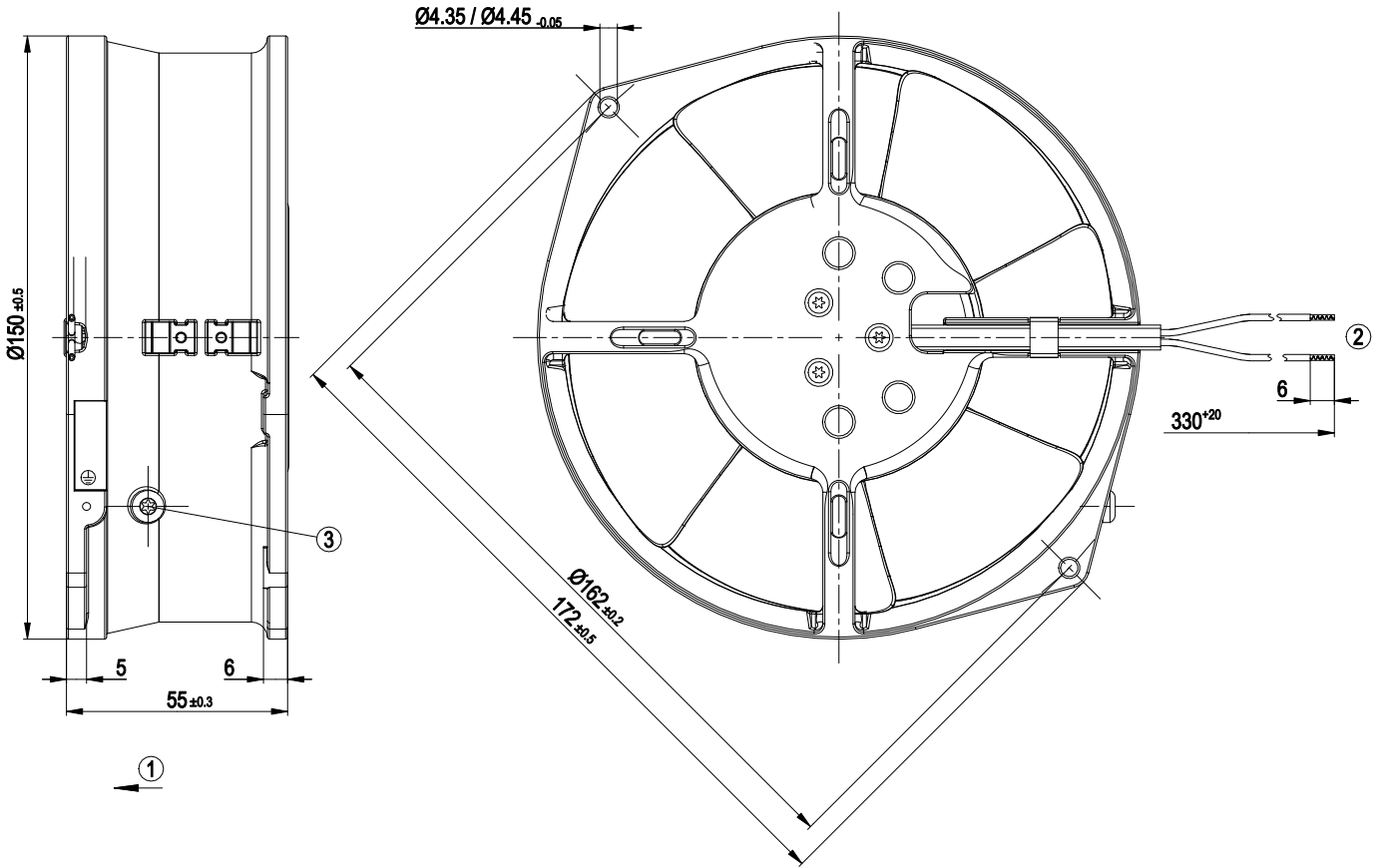

1	Direction of air flow "V"
2	Cable PVC AWG20, 2x crimped splices
3	M4 screw for fastening ground connector



EC axial compact fan

sickle-shaped blades (S series), with brushless DC motor

Connection diagram

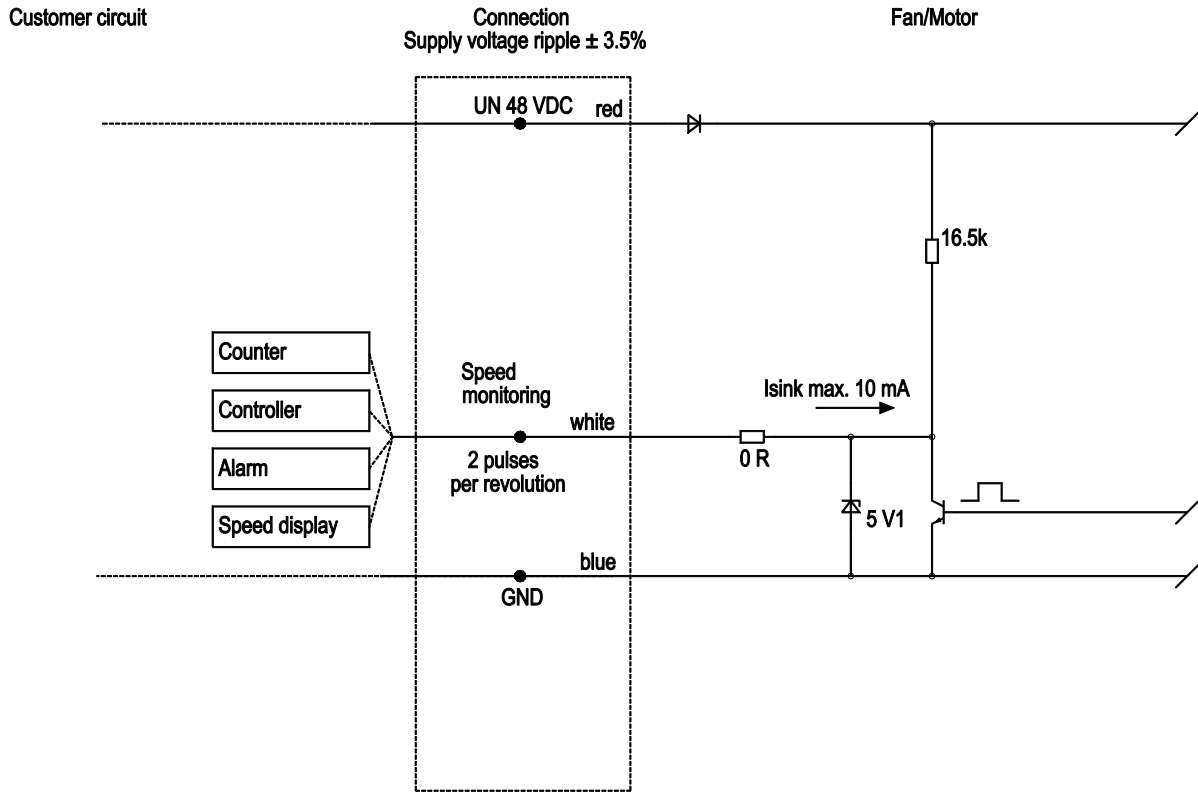

Tach output 5.1 V 2 pulses per revolution optional



Curves: Air performance

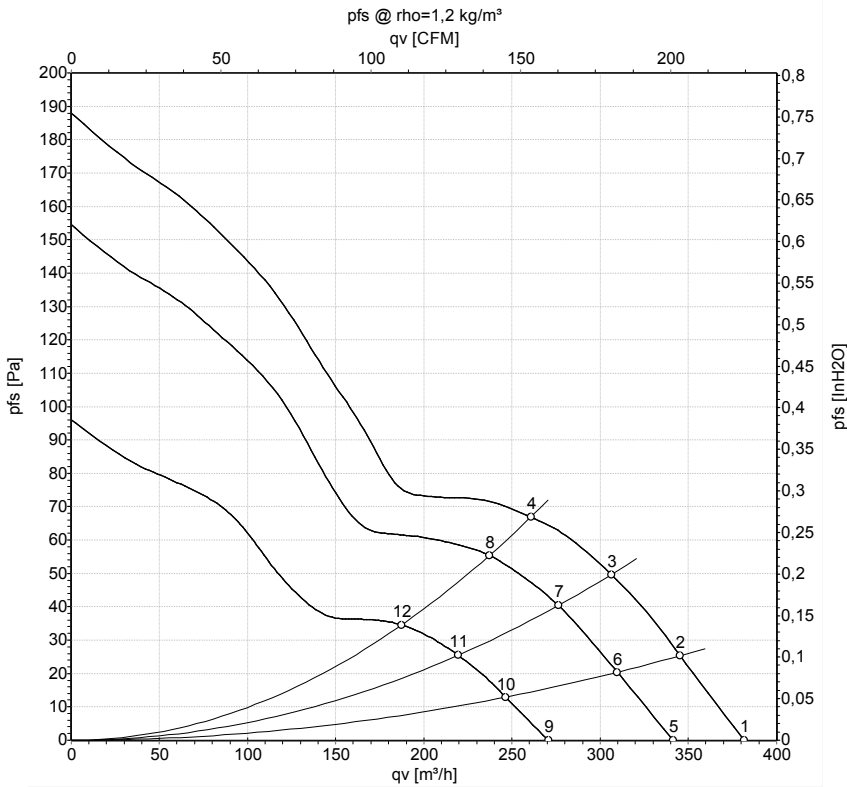

Measurement: LU-11766-1
 Measurement: LU-11765-1
 Measurement: LU-11794-1

Air performance measured according to ISO 5801 installation category A. For detailed information on the measurement setup, contact ebmpapst. Intake sound level: Sound power level according to ISO 13347 / sound pressure level measured at 1 m distance from fan axis. The values given are valid under the specified measuring conditions and may vary due to conditions of installation. For deviations from the standard configuration, the parameters have to be checked on the installed unit.

Measured values

	U	n	P _{ed}	I	q _v	p _{fs}	q _v	p _{fs}
	V	min ⁻¹	W	A	m ³ /h	Pa	cfm	inH2O
1	56	3260	18	0.32	380	0	225	0.00
2	56	3215	18	0.33	345	25	205	0.10
3	56	3170	19	0.34	305	50	180	0.20
4	56	3140	19	0.35	260	67	155	0.27
5	48	2950	14	0.27	340	0	200	0.00
6	48	2890	14	0.28	310	20	180	0.08
7	48	2835	14	0.29	275	40	160	0.16
8	48	2825	14	0.30	235	55	140	0.22
9	36	2345	7.0	0.20	270	0	160	0.00
10	36	2320	7.0	0.21	245	13	145	0.05
11	36	2295	8.0	0.22	220	25	130	0.10
12	36	2280	8.0	0.22	185	35	110	0.14

U = Power supply · n = Speed (rpm) · P_{ed} = Power consumption · I = Current draw · q_v = Air flow · p_{fs} = Pressure increase

