

W2G115-AD17-01 ebmpapst Datasheet

sales@fansco.com

www.fansco.com

Nominal data

Type	W2G115-AD17-01	
Motor	M2G045-BA	
Nominal voltage	VDC	24
Type of data definition		fa
Speed	min ⁻¹	2800
Power input	W	4.7
Min. ambient temperature	°C	- 25
Max. ambient temperature	°C	+72

ml = max. load · me = max. efficiency · fa = running at free air · cs = customer specs · cu = customer unit
Subject to alterations



Technical features

Mass	0.6 kg
Size	115 mm
Surface of rotor	Coated in black
Material of blades	Sheet steel, coated in black
Material of wall ring	Die-cast aluminium, coated in black
Direction of air flow	"V"
Direction of rotation	Counter-clockwise, seen on rotor
Type of protection	IP 22; Depending on installation and position
Insulation class	"B"
Max. permissible ambient motor temp. (transp./ storage)	+ 80 °C
Min. permissible ambient motor temp. (transp./storage)	- 40 °C
Mounting position	Any
Condensate discharge holes	None
Operation mode	S1
Motor bearing	Ball bearing
Technical features	- Motor current limit
EMC interference immunity	Acc. to EN 61000-6-2 (industrial environment)
EMC interference emission	Acc. to EN 55022 (Class A)
Motor protection	Reverse polarity and locked-rotor protection
Protection class	I (if protective earth is connected by customer)
Product conforming to standard	EN 60335-1
Approval	UL 507; CSA C22.2 Nr.113

Product drawing

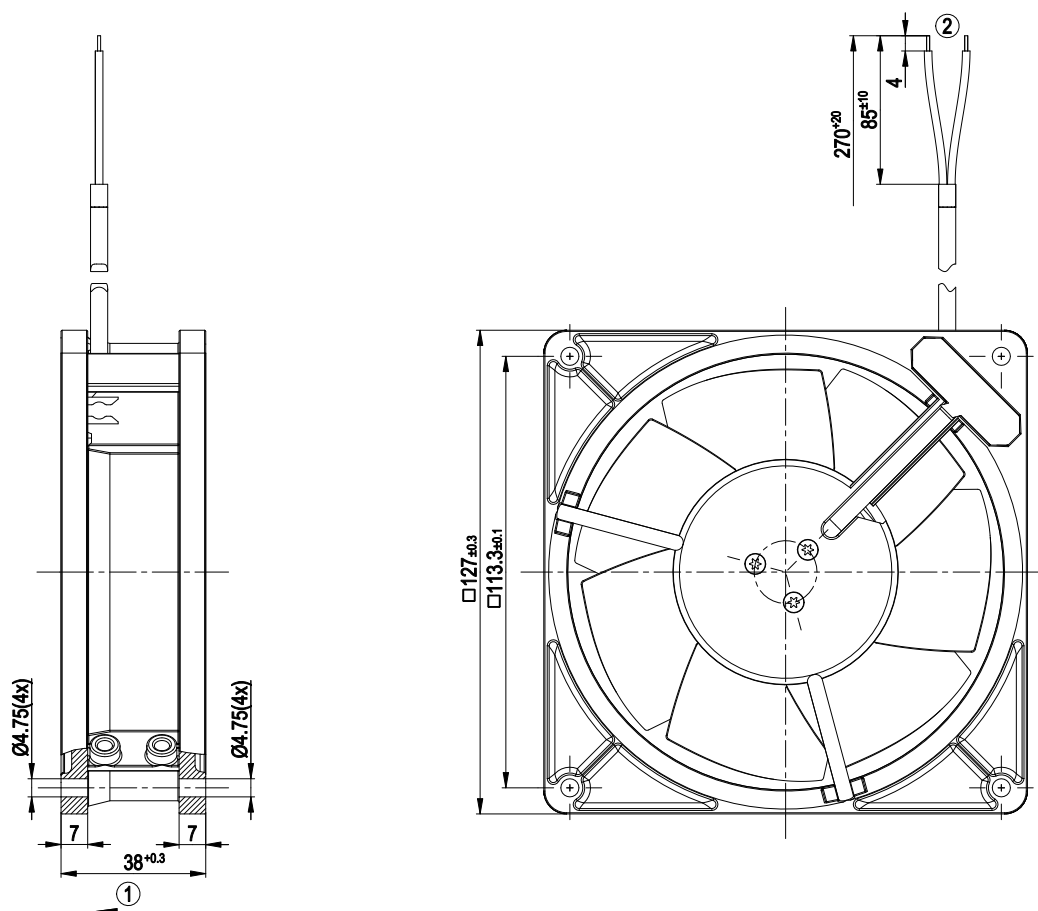

- | | |
|---|--|
| 1 | Direction of air flow "V" |
| 2 | Connection line AWG22 2X, tin-plated lead tips |

Connection screen

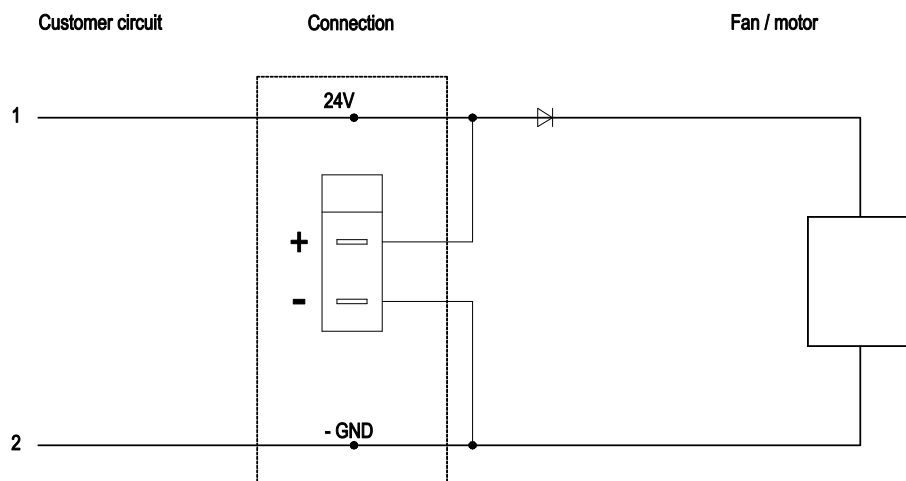

Line	No.	Signal	Colour	Function / assignment
1	1	UN +24V	red	Power supply +24 V/voltage range refer to rating plate, residual ripple $\pm 3.5\%$
1	2	GND	blue	Reference mass

Charts: Air flow

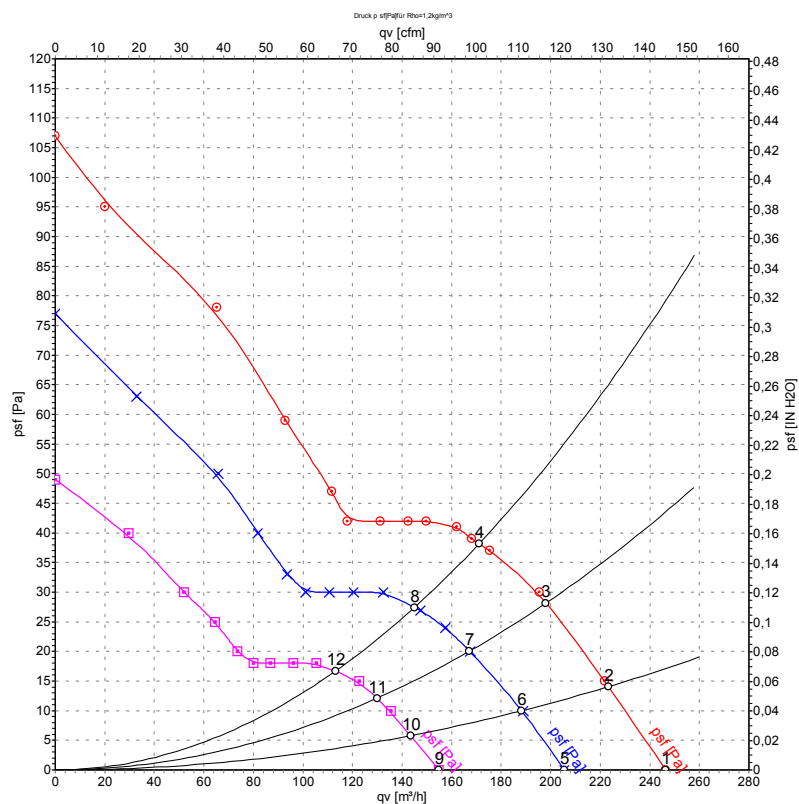

Measurement: LU-9346
 Measurement: LU-9345
 Measurement: LU-9347

Air performance measured as per ISO 5801 Installation category A. For detailed information on the measuring set-up, please contact ebmpapst. Suction-side noise levels: L_{WA} measured as per ISO 13347 / L_{pA} measured with 1m distance to fan axis. The values given are valid under the measuring conditions mentioned above and may vary according to the actual installation situation. With any deviation from the standard set-up, the specific values have to be checked and reviewed with the unit installed.

Measured values

	U	n	P _e	I	qv	p _{sf}
	V	min ⁻¹	W	A	m ³ /h	Pa
1	30	3405	8.0	0.27	245	0
2	30	3305	8.2	0.27	225	14
3	30	3225	8.9	0.30	200	28
4	30	3165	9.2	0.31	170	38
5	24	2800	4.7	0.20	205	0
6	24	2780	4.9	0.21	190	10
7	24	2710	5.2	0.22	165	20
8	24	2665	5.6	0.23	145	28
9	18	2180	2.40	0.13	155	0
10	18	2140	2.58	0.14	145	6
11	18	2095	2.74	0.15	130	12
12	18	2065	2.80	0.16	115	17

