

W2E250-HQ52-11 ebmpapst Datasheet  
 sales@fansco.com  
 www.fansco.com

## Nominal data

Type	W2E250-HQ52-11						
Motor	M2E068-DF						
Phase		1~	1~	1~	1~	1~	1~
Nominal voltage	VAC	230	230	230	230	230	230
Frequency	Hz	50	50	60	60	60	60
Type of data definition		ml	ml	ml	ml	ml	ml
Valid for approval / standard		CE	CE	CE	UL 2111	CE	UL 2111
Speed	min <sup>-1</sup>	2530	2500	2600	2600	2730	2730
Power input	W	142	136	185	195	190	210
Current draw	A	0.63	0.61	0.82	0.83	0.84	0.89
Motor capacitor	µF	3.5	3	3	3	3.5	3.5
Capacitor voltage	VDB	400	400	400	400	400	400
Capacitor standard		P0 (CE)	P0 (CE)	P0 (CE)	UL	P0 (CE)	UL
Max. back pressure	Pa	120	120	130	130	105	105
Min. ambient temperature	°C	-25	-25	-25	-25	-25	-25
Max. ambient temperature	°C	70	70	70	70	55	55
Starting current	A	1.17	1.15	1.07		1.12	

ml = Max. load · me = Max. efficiency · fa = Running at free air · cs = Customer specs · cu = Customer unit  
 Subject to alterations

## Data according to ErP directive

		Actual	Request 2013	Request 2015
Installation category	A			
Efficiency category	Static			
Variable speed drive	No			
Specific ratio*	1.00			
Overall efficiency $\eta_{es}$	%	28.3	24.3	28.3
Efficiency grade N		40	36	40
Power input $P_e$	kW	0.14		
Air flow $q_v$	m <sup>3</sup> /h	1205		
Pressure increase $p_{fs}$	Pa	121		
Speed n	min <sup>-1</sup>	2530		

Data definition with optimum efficiency. LU-155463  
 The ErP data is determined using a motor-impeller combination in a standardised measurement configuration.



### Technical features

<b>Mass</b>	3.3 kg
<b>Size</b>	250 mm
<b>Surface of rotor</b>	Coated in black
<b>Material of blades</b>	Press-fitted sheet steel blank, sprayed with PP plastic
<b>Material of wall ring</b>	Die-cast aluminium
<b>Number of blades</b>	7
<b>Direction of air flow</b>	"V"
<b>Direction of rotation</b>	Counter-clockwise, seen on rotor
<b>Type of protection</b>	IP 44; Depending on installation and position
<b>Insulation class</b>	"F"
<b>Humidity class</b>	F0
<b>Max. permissible ambient motor temp. (transp./ storage)</b>	+ 80 °C
<b>Min. permissible ambient motor temp. (transp./storage)</b>	- 40 °C
<b>Mounting position</b>	Any
<b>Condensate discharge holes</b>	None
<b>Operation mode</b>	S1
<b>Motor bearing</b>	Ball bearing
<b>Touch current acc. IEC 60990 (measuring network Fig. 4, TN system)</b>	< 0.75 mA
<b>Electrical leads</b>	Via terminal strips, integrated capacitor connected via terminal strips
<b>Motor protection</b>	Thermal overload protector (TOP) wired internally
<b>Cable exit</b>	Variable
<b>Protection class</b>	I (if protective earth is connected by customer)
<b>Product conforming to standard</b>	EN 60335-1; CE
<b>Approval</b>	UL 2111; CSA C22.2 Nr.77

## Product drawing

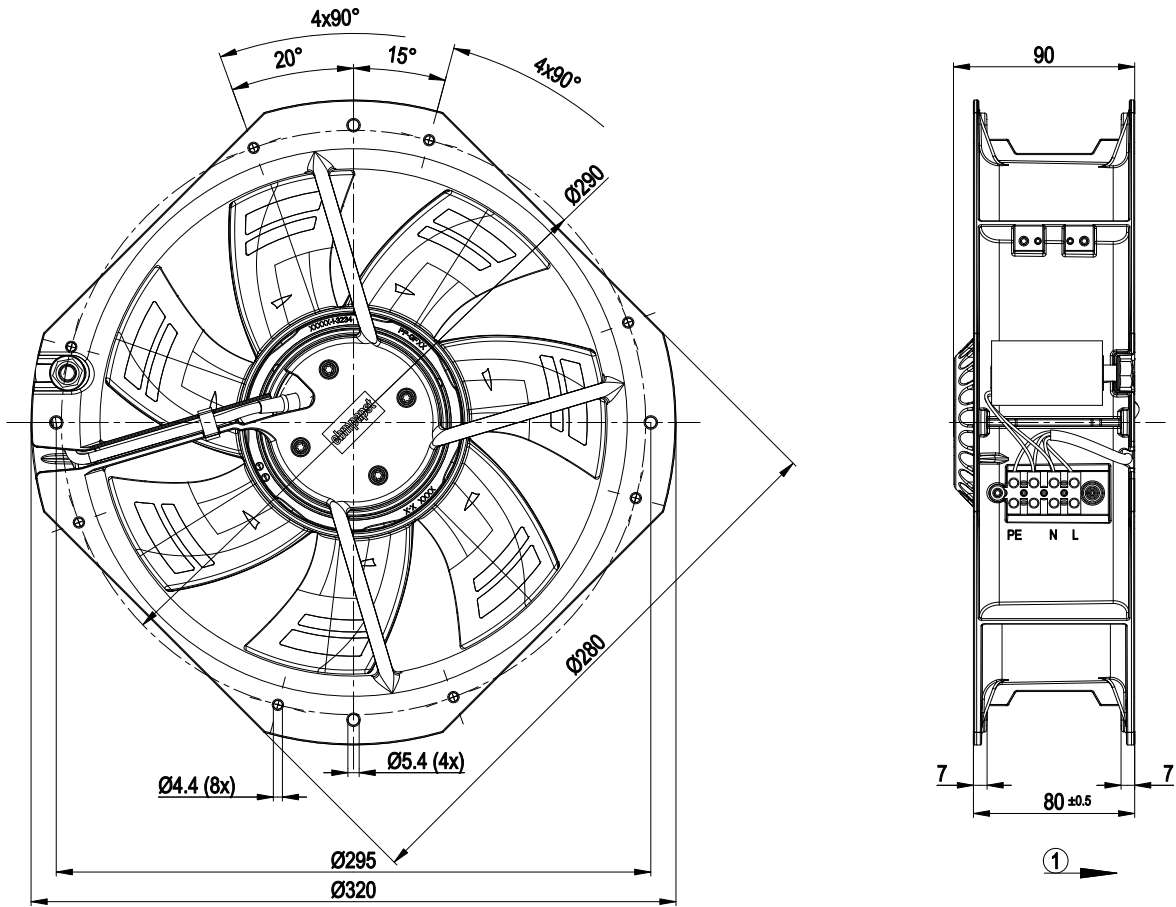

1 Direction of air flow "V"

## Connection screen

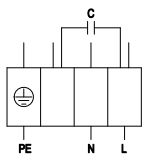

PE	green/yellow	N	blue	L	black
----	--------------	---	------	---	-------



## Charts: Air flow 50 Hz

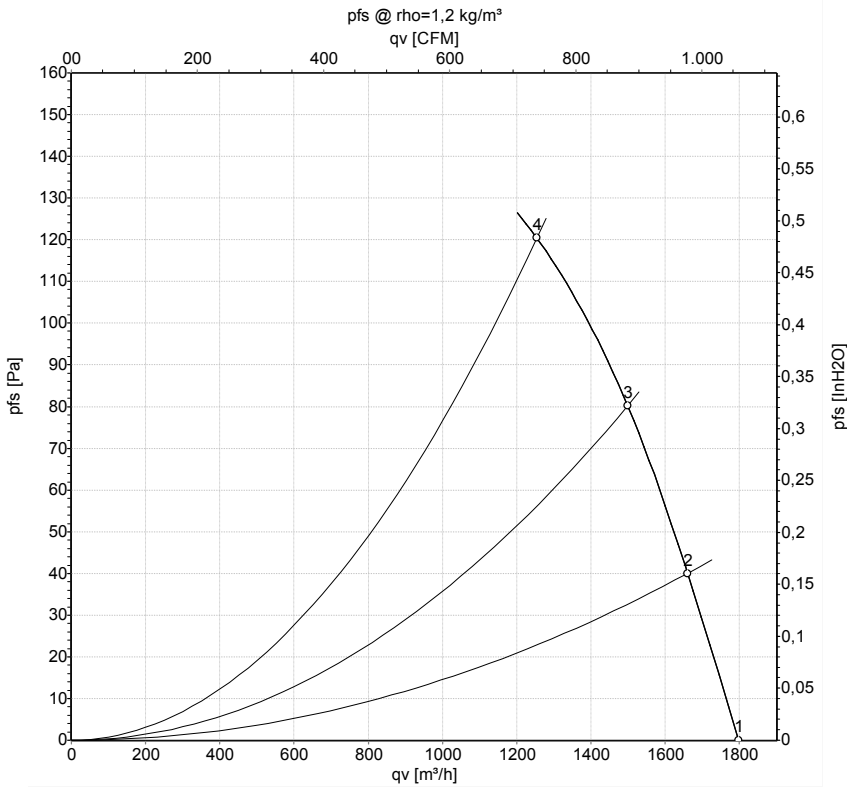

Measurement: LU-155463

Air performance measured as per ISO 5801 Installation category A. For detailed information on the measuring set-up, please contact ebm-papst. Suction-side noise levels:  $L_{wA}$  measured as per ISO 13347 /  $L_{pA}$  measured with 1m distance to fan axis. The values given are valid under the measuring conditions mentioned above and may vary according to the actual installation situation. With any deviation from the standard set-up, the specific values have to be checked and reviewed with the unit installed.

## Measured values

	U	f	n	$P_e$	I	$L_{pA_{in}}$	$L_{wA_{in}}$	qv	$p_{fs}$
	V	Hz	min <sup>-1</sup>	W	A	dB(A)	dB(A)	m <sup>3</sup> /h	Pa
1	230	50	2690	116	0.51	63	69	1800	0
2	230	50	2640	125	0.55	63	70	1660	40
3	230	50	2585	133	0.58	63	70	1500	80
4	230	50	2530	142	0.63	63	70	1255	120

U = Supply voltage · f = Frequency · n = Speed ·  $P_e$  = Power input · I = Current draw ·  $L_{pA_{in}}$  = Sound pressure level inlet side ·  $L_{wA_{in}}$  = Sound power level inlet side · qv = Air flow  
 $p_{fs}$  = Pressure increase



## Charts: Air flow 60 Hz

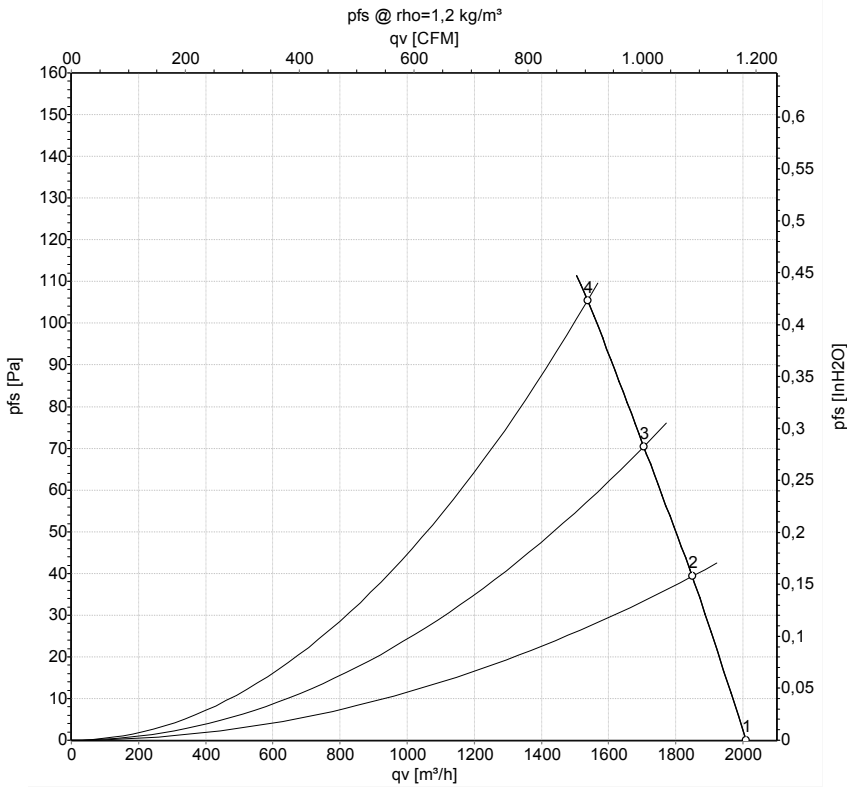

Measurement: LU-155467

Air performance measured as per ISO 5801 Installation category A. For detailed information on the measuring set-up, please contact ebm-papst. Suction-side noise levels: L<sub>wA</sub> measured as per ISO 13347 / L<sub>pA</sub> measured with 1m distance to fan axis. The values given are valid under the measuring conditions mentioned above and may vary according to the actual installation situation. With any deviation from the standard set-up, the specific values have to be checked and reviewed with the unit installed.

## Measured values

	U	f	n	P <sub>e</sub>	I	L <sub>pA<sub>in</sub></sub>	L <sub>wA<sub>in</sub></sub>	q <sub>v</sub>	p <sub>fs</sub>
	V	Hz	min <sup>-1</sup>	W	A	dB(A)	dB(A)	m <sup>3</sup> /h	Pa
1	230	60	2990	167	0.73	65	72	2010	0
2	230	60	2920	174	0.76	71	79	1850	40
3	230	60	2845	181	0.79	74	82	1705	70
4	230	60	2730	190	0.84	72	80	1535	105

U = Supply voltage · f = Frequency · n = Speed · P<sub>e</sub> = Power input · I = Current draw · L<sub>pA<sub>in</sub></sub> = Sound pressure level inlet side · L<sub>wA<sub>in</sub></sub> = Sound power level inlet side · q<sub>v</sub> = Air flow  
 p<sub>fs</sub> = Pressure increase

