

W2E250-HL06-13

AC axial compact fan

sickle-shaped blades (S series)



W2E250-HL06-13 ebmpapst Datasheet

sales@fansco.com

www.fansco.com

Limited partnership · Headquarters Muldingen

Amtsgericht (court of registration) Stuttgart · HRA 590344

General partner Elektrobau Muldingen GmbH · Headquarters Muldingen

Amtsgericht (court of registration) Stuttgart · HRB 590142

Nominal data

Type	W2E250-HL06-13			
Motor	M2E068-CF			
Phase		1~	1~	1~
Nominal voltage	VAC	230	230	230
Frequency	Hz	50	60	60
Method of obtaining data		fa	fa	fa
Valid for approval/standard		-	-	UL 2111
Speed (rpm)	min ⁻¹	2550	2700	2700
Power consumption	W	127	180	195
Current draw	A	0.56	0.79	0.83
Capacitor	µF	4	4	4
Capacitor voltage	VDB	400	400	400
Capacitor standard		S0 (CE)	S0 (CE)	UL
Max. back pressure	Pa	100	100	100
Max. back pressure	inH ₂ O	0.4	0.4	0.4
Min. ambient temperature	°C	-25	-25	-25
Max. ambient temperature	°C	60	45	45
Starting current	A	0.88	0.87	0.87

ml = Max. load · me = Max. efficiency · fa = Free air · cs = Customer specification · ce = Customer equipment
Subject to change



Technical description

Weight	2.9 kg
Fan size	250 mm
Rotor surface	Painted black
Blade material	Sheet steel, painted black
Fan housing material	Die-cast aluminum
Number of blades	7
Airflow direction	"V"
Direction of rotation	Counterclockwise, viewed toward rotor
Degree of protection	IP44; installation- and position-dependent
Insulation class	"F"
Moisture (F) / Environmental (H) protection class	H0+
Max. permitted ambient temp. for motor (transport/storage)	+ 80 °C
Min. permitted ambient temp. for motor (transport/storage)	- 40 °C
Installation position	Any
Condensation drainage holes	None
Mode	S1
Motor bearing	Ball bearing
Touch current according to IEC 60990 (measuring circuit Fig. 4, TN system)	< 0.75 mA
Electrical hookup	Via terminal strip, capacitor connected
Motor protection	Thermal overload protector (TOP) internally connected
With cable	Variable
Protection class	I (with customer connection of protective earth)
Motor capacitor according to EN 60252-1 in safety protection class	S0
Conformity with standards	EN 60335-1
Approval	CCC; CSA C22.2 No. 100; UL 1004-1

AC axial compact fan

sickle-shaped blades (S series)

Product drawing

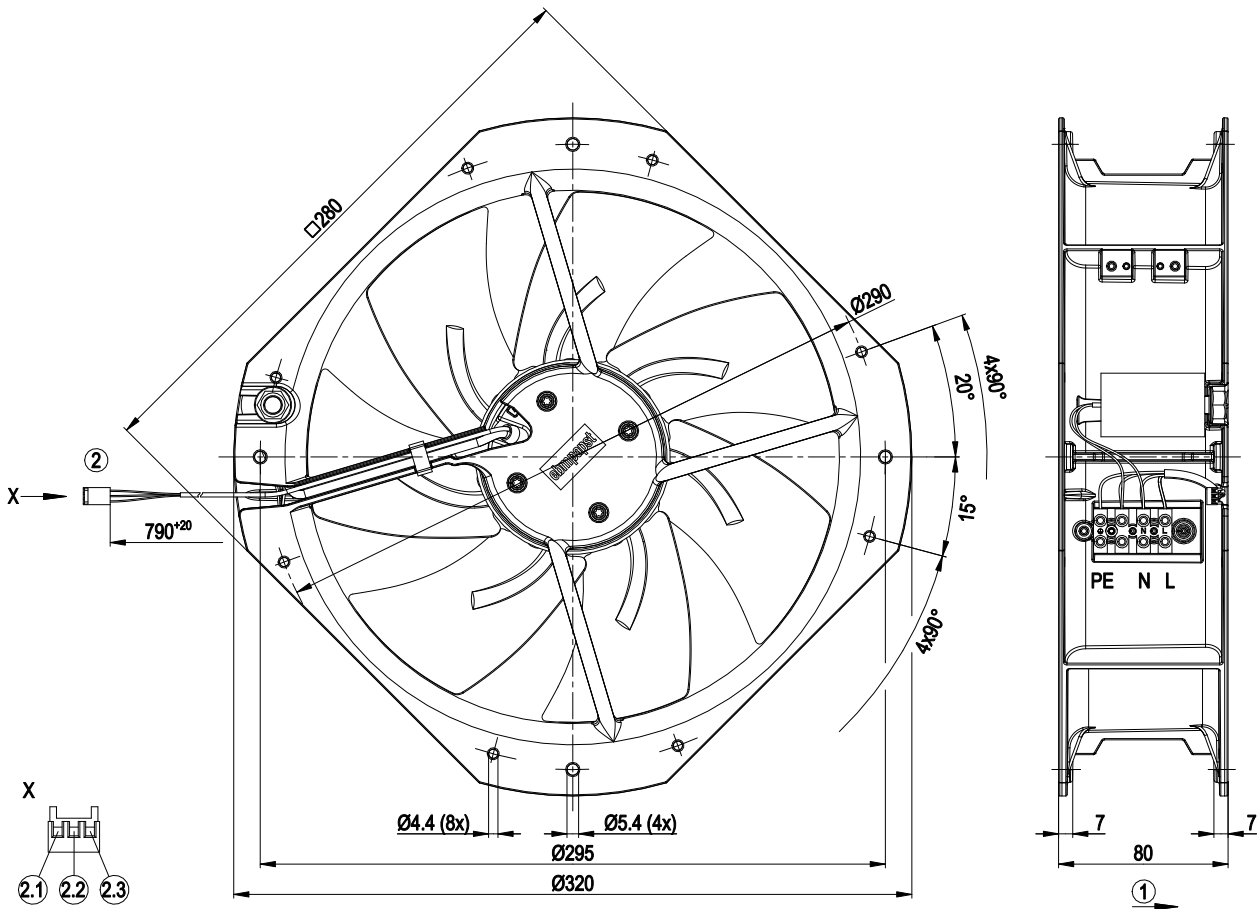

1	Direction of air flow "V"
2	Cable Raychem Spec. 44, AWG24, 3-pole connector housing Molex 22-01-2035, 3x plug pin Molex 08-50-0031
2.1	red (Hall IC)
2.2	white (Hall IC)
2.3	black (Hall IC)



Connection diagram

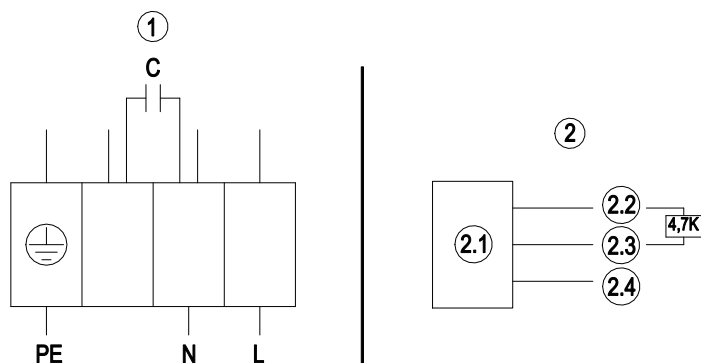

1	Fan connection diagram
PE	green/yellow
N	black
L	blue
2	Hall IC circuit
2.1	Hall IC
2.2	red (+5 V)
2.3	white (out)
2.4	black (0 V)

Curves: Air performance 50 Hz

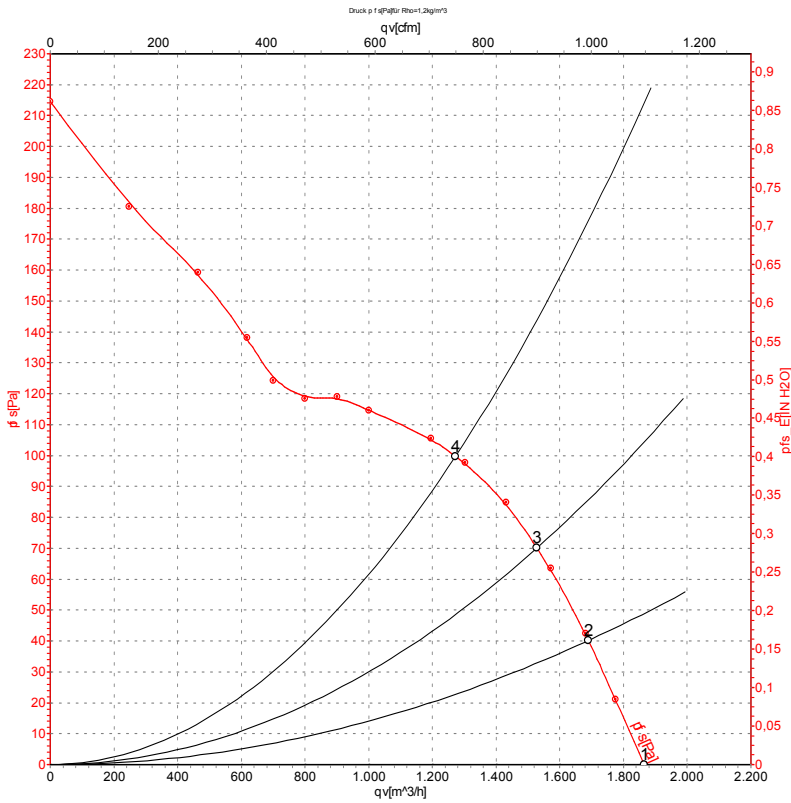

Measurement: LU-59959-1

Air performance measured according to ISO 5801 installation category A. For detailed information on the measurement setup, contact ebmpapst. Intake sound level: Sound power level according to ISO 13347 / sound pressure level measured at 1 m distance from fan axis. The values given are valid under the specified measuring conditions and may vary due to conditions of installation. For deviations from the standard configuration, the parameters have to be checked on the installed unit.

Measured values

	U	f	n	Pe	I	qv	ps	qv	ps
	V	Hz	min ⁻¹	W	A	m ³ /h	Pa	cfm	inH2O
1	230	50	2550	127	0.56	1865	0	1100	0.00
2	230	50	2485	136	0.59	1690	40	995	0.16
3	230	50	2440	141	0.61	1530	70	900	0.28
4	230	50	2385	146	0.63	1275	100	750	0.40

U = Power supply · f = Frequency · n = Speed (rpm) · Pe = Power consumption · I = Current draw · qv = Air flow · ps = Pressure increase



Curves: Air performance 60 Hz

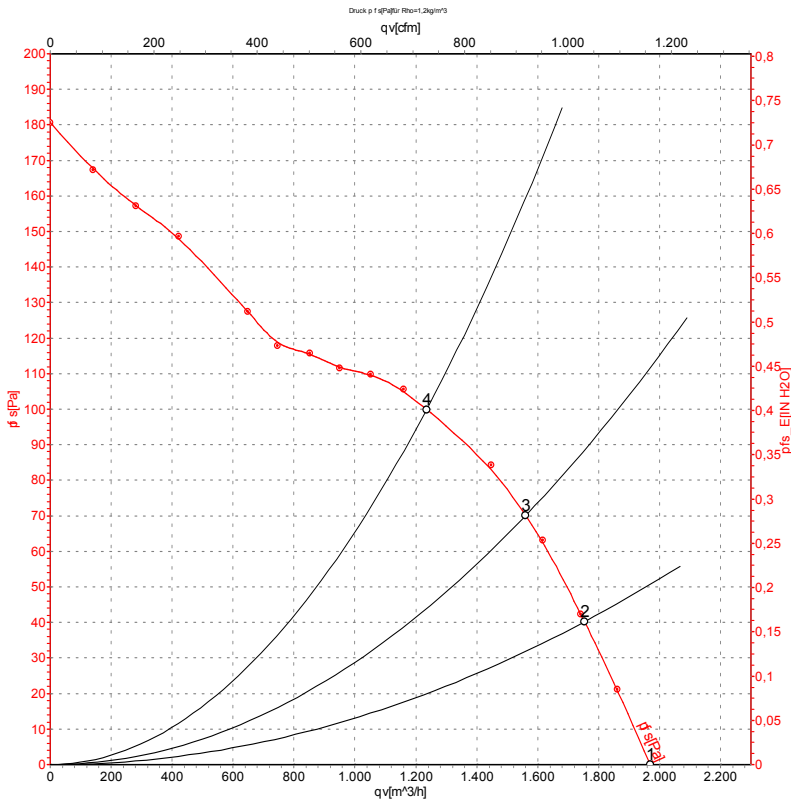

Measurement: LU-59960-1

Air performance measured according to ISO 5801 installation category A. For detailed information on the measurement setup, contact ebm-papst. Intake sound level: Sound power level according to ISO 13347 / sound pressure level measured at 1 m distance from fan axis. The values given are valid under the specified measuring conditions and may vary due to conditions of installation. For deviations from the standard configuration, the parameters have to be checked on the installed unit.

Measured values

	U	f	n	P _e	I	q _v	p _{fs}	q _v	p _{fs}
	V	Hz	min ⁻¹	W	A	m ³ /h	Pa	cfm	inH ₂ O
1	230	60	2700	180	0.79	1970	0	1160	0.00
2	230	60	2575	186	0.82	1755	40	1030	0.16
3	230	60	2485	189	0.83	1560	70	920	0.28
4	230	60	2370	192	0.84	1235	100	725	0.40

U = Power supply · f = Frequency · n = Speed (rpm) · P_e = Power consumption · I = Current draw · q_v = Air flow · p_{fs} = Pressure increase

