

W2E250-HJ28-09

AC axial compact fan

sickle-shaped blades (S series)



W2E250-HJ28-09 ebmpapst Datasheet

sales@fansco.com

www.fansco.com

Nominal data

Type	W2E250-HJ28-09			
Motor	M2E068-DF			
Phase		1~	1~	1~
Nominal voltage	VAC	230	230	230
Frequency	Hz	50	60	60
Method of obtaining data		fa	fa	fa
Valid for approval/standard		-	-	UL 2111
Speed (rpm)	min ⁻¹	2600	2850	2850
Power consumption	W	115	160	180
Current draw	A	0.51	0.7	
Capacitor	µF	3.5	3.5	3.5
Capacitor voltage	VDB	400	400	400
Capacitor standard		P0 (CE)	P0 (CE)	P0 (CE)
Max. back pressure	Pa	150	120	120
Max. back pressure	inH ₂ O	0.6	0.48	0.48
Min. ambient temperature	°C	-25	-25	-25
Max. ambient temperature	°C	70	70	70

ml = Max. load · me = Max. efficiency · fa = Free air · cs = Customer specification · ce = Customer equipment
Subject to change



Technical description

Weight	3.2 kg
Fan size	250 mm
Rotor surface	Painted black
Blade material	Sheet steel, painted black
Fan housing material	Die-cast aluminum
Number of blades	7
Airflow direction	"V"
Direction of rotation	Counterclockwise, viewed toward rotor
Degree of protection	IP44; installation- and position-dependent
Insulation class	"F"
Moisture (F) / Environmental (H) protection class	H0 - dry environment
Max. permitted ambient temp. for motor (transport/storage)	+ 80 °C
Min. permitted ambient temp. for motor (transport/storage)	- 40 °C
Installation position	Any
Condensation drainage holes	None
Mode	S1
Motor bearing	Ball bearing
Touch current according to IEC 60990 (measuring circuit Fig. 4, TN system)	< 0.75 mA
Electrical hookup	Via terminal strip, capacitor connected
Motor protection	Thermal overload protector (TOP) internally connected
With cable	Variable
Protection class	I (with customer connection of protective earth)
Motor capacitor according to EN 60252-1 in safety protection class	P0/S0
Conformity with standards	EN 60335-1
Approval	UL 2111; CCC; CSA C22.2 No. 77

Product drawing

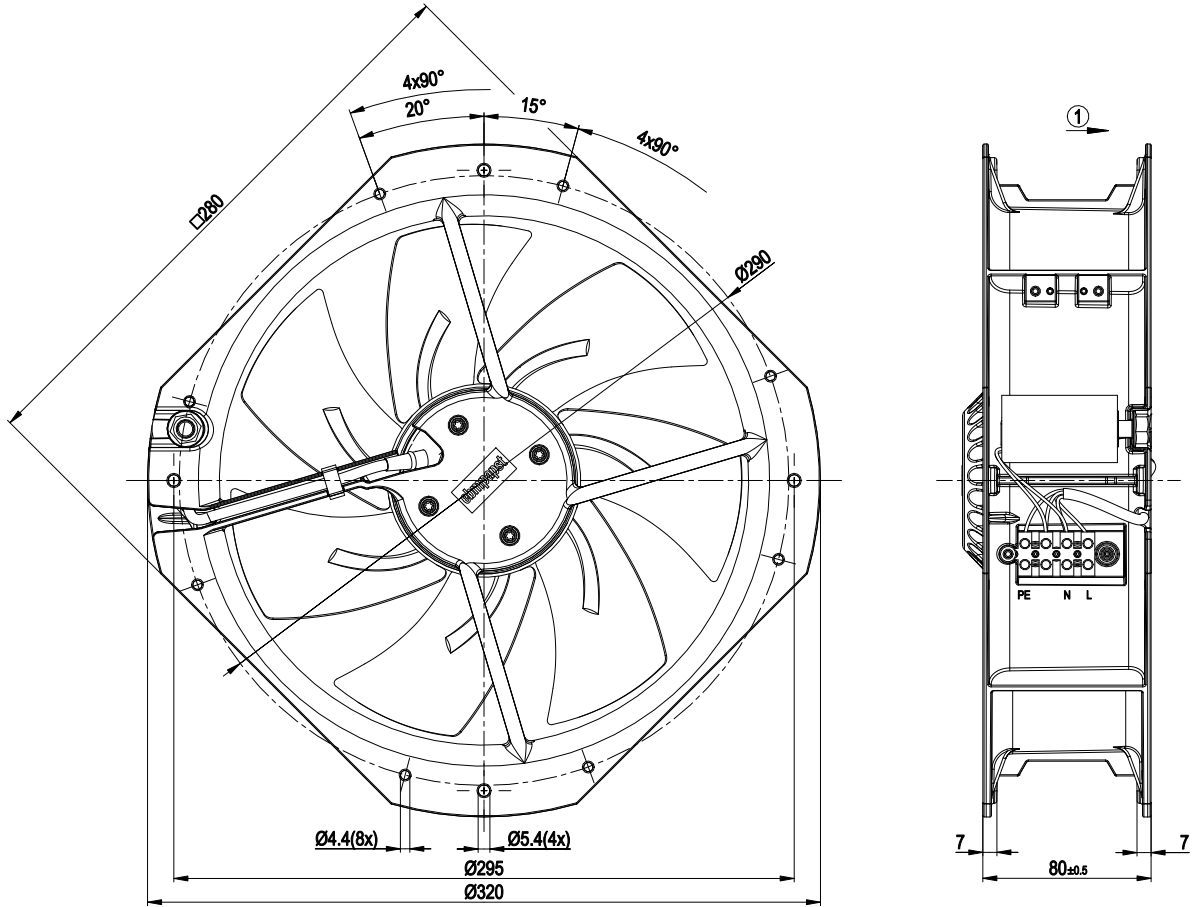

1 Direction of air flow "V"

Connection diagram

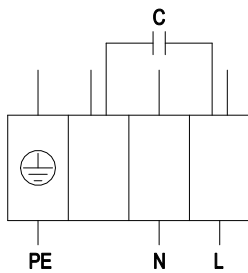

PE	green/yellow	N	blue	L	black
----	--------------	---	------	---	-------



Curves: Air performance 50 Hz

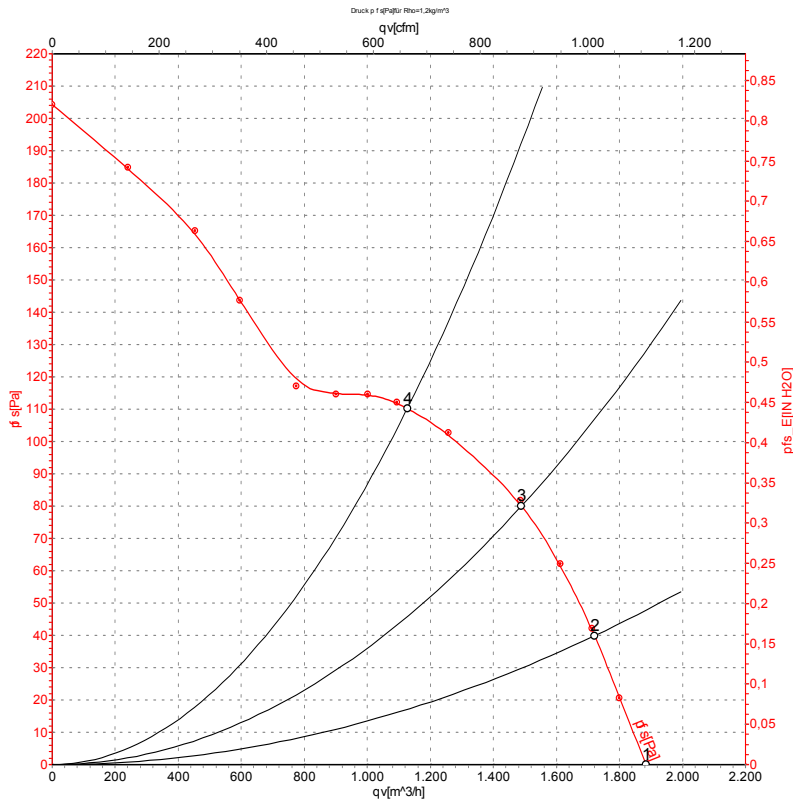

Measurement: LU-29331-1

Air performance measured according to ISO 5801 installation category A. For detailed information on the measurement setup, contact ebm-papst. Intake sound level: Sound power level according to ISO 13347 / sound pressure level measured at 1 m distance from fan axis. The values given are valid under the specified measuring conditions and may vary due to conditions of installation. For deviations from the standard configuration, the parameters have to be checked on the installed unit.

Measured values

	U	f	n	P _e	I	qv	p _{fs}	qv	p _{fs}
	V	Hz	min ⁻¹	W	A	m ³ /h	Pa	CFM	inH2O
1	230	50	2600	115	0.51	1885	0	1110	0.00
2	230	50	2550	124	0.54	1720	40	1015	0.16
3	230	50	2485	133	0.57	1490	80	875	0.32
4	230	50	2400	142	0.62	1125	110	665	0.44

U = Power supply · f = Frequency · n = Speed (rpm) · P_e = Power consumption · I = Current draw · qv = Air flow · p_{fs} = Pressure increase



Curves: Air performance 60 Hz

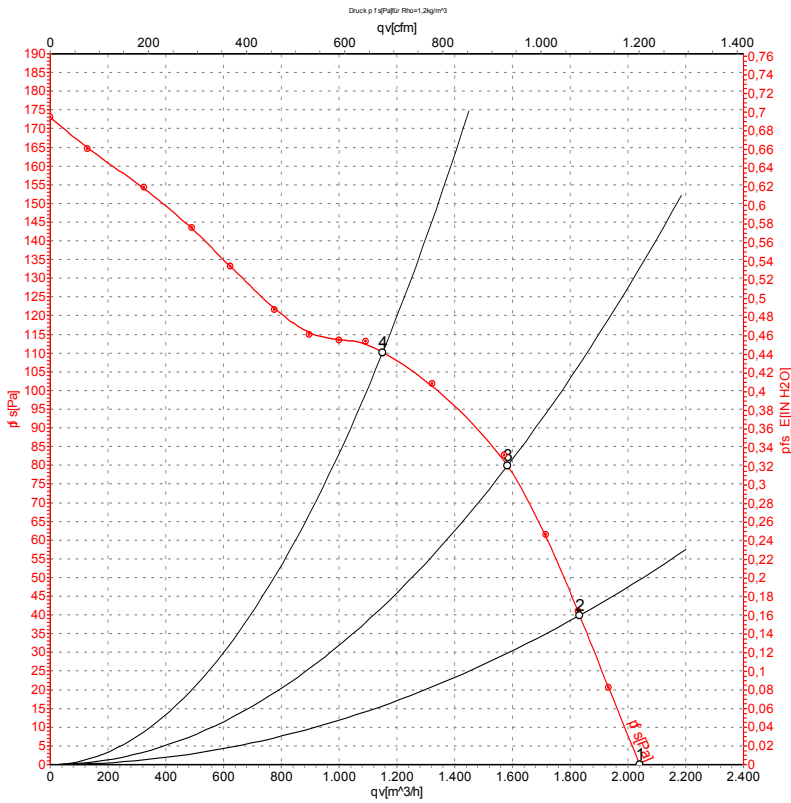

Measurement: LU-29332-1

Air performance measured according to ISO 5801 installation category A. For detailed information on the measurement setup, contact ebm-papst. Intake sound level: Sound power level according to ISO 13347 / sound pressure level measured at 1 m distance from fan axis. The values given are valid under the specified measuring conditions and may vary due to conditions of installation. For deviations from the standard configuration, the parameters have to be checked on the installed unit.

Measured values

	U	f	n	P _e	I	qv	p _{fs}	qv	p _{fs}
	V	Hz	min ⁻¹	W	A	m ³ /h	Pa	CFM	inH ₂ O
1	230	60	2850	160	0.70	2040	0	1200	0.00
2	230	60	2700	167	0.73	1835	40	1080	0.16
3	230	60	2585	176	0.76	1585	80	930	0.32
4	230	60	2410	183	0.80	1150	110	675	0.44

U = Power supply · f = Frequency · n = Speed (rpm) · P_e = Power consumption · I = Current draw · qv = Air flow · p_{fs} = Pressure increase

