

AC axial fan

sickle-shaped blades (S series)

Fan housing with guard grille

W2E250-CL06-75 ebmpapst Datasheet

sales@fansco.com

www.fansco.com

Nominal data

Type	W2E250-CL06-75			
Motor	M2E068-CF			
Phase		1~	1~	1~
Nominal voltage	VAC	230	230	230
Frequency	Hz	50	60	60
Method of obtaining data		fa	fa	fa
Valid for approval/standard		CE	CE	UL 2111
Speed	min ⁻¹	2450	2600	2600
Power consumption	W	115	150	165
Current draw	A	0.51	0.66	0.70
Capacitor	μF	3	3	3
Capacitor voltage	VDB	400	400	400
Capacitor standard		P0 (CE)	P0 (CE)	UL
Max. back pressure	Pa	120	85	85
Min. ambient temperature	°C	-25	-25	-25
Max. ambient temperature	°C	65	50	50
Starting current	A	0.88	0.87	

ml = Max. load · me = Max. efficiency · fa = Free air · cs = Customer specification · ce = Customer equipment
Subject to change



AC axial fan

sickle-shaped blades (S series)

Fan housing with guard grille

Technical description

Weight	2.2 kg
Fan size	250 mm
Rotor surface	Painted black
Blade material	Sheet steel, painted black
Fan housing material	Sheet steel, pre-galvanized and coated with black plastic (RAL 9005)
Guard grille material	Steel, coated with black plastic (RAL 9005)
Number of blades	7
Airflow direction	"V"
Direction of rotation	Counterclockwise, viewed toward rotor
Degree of protection	IP44; installation- and position-dependent
Insulation class	"B"
Moisture (F) / Environmental (H) protection class	F1-2
Max. permitted ambient temp. for motor (transport/storage)	+ 80 °C
Min. permitted ambient temp. for motor (transport/storage)	- 40 °C
Installation position	Any
Condensation drainage holes	On rotor side
Mode	S1
Motor bearing	Ball bearing
Touch current according to IEC 60990 (measuring circuit Fig. 4, TN system)	< 0.75 mA
Motor protection	Thermal overload protector (TOP) internally connected
With cable	Variable
Protection class	I (with customer connection of protective earth)
Conformity with standards	EN 60335-1; CE
Approval	CSA C22.2 No. 77; UL 1004-3



AC axial fan

sickle-shaped blades (S series)

Fan housing with guard grille

Product drawing

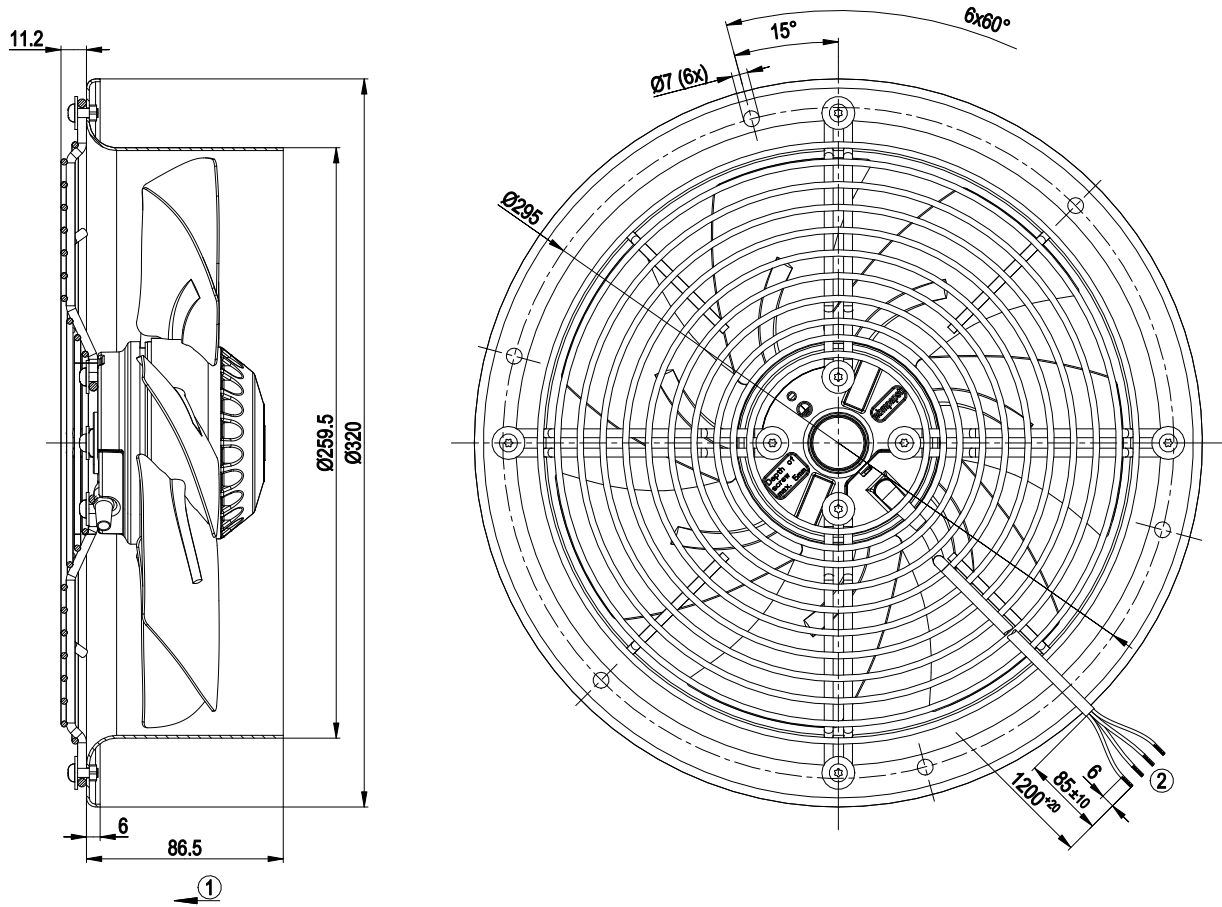

- 1 Direction of air flow "V"
- 2 Cable PVC 4G AWG20 UL, 4x crimped splices

Connection diagram

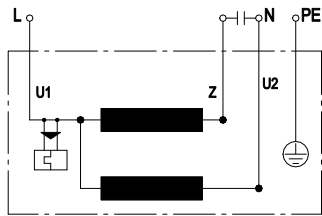

U1	blue	Z	brown	U2	black
PE	green/yellow				



AC axial fan

sickle-shaped blades (S series)

Fan housing with guard grille

Curves: Air performance 50 Hz

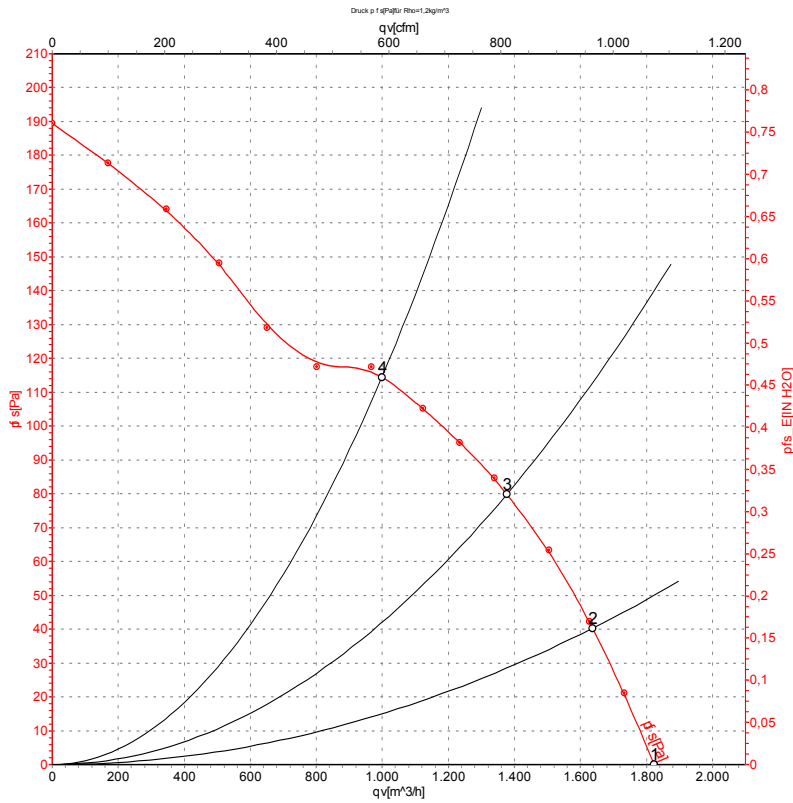

Measurement: LU-59608

Air performance measured according to ISO 5801 installation category A. For detailed information on the measurement setup, contact ebm-papst. Intake sound level: Sound power level according to ISO 13347 / sound pressure level measured at 1 m distance from fan axis. The values given are valid under the specified measuring conditions and may vary due to conditions of installation. For deviations from the standard configuration, the parameters have to be checked on the installed unit.

Measured values

	U	f	n	P _e	I	qv	p _{fs}
	V	Hz	min ⁻¹	W	A	m ³ /h	Pa
1	230	50	2450	115	0.51	1820	0
2	230	50	2420	120	0.52	1635	40
3	230	50	2335	125	0.56	1375	80
4	230	50	2270	134	0.58	1000	115

U = Power supply · f = Frequency · n = Speed · P_e = Power consumption · I = Current draw · qv = Air flow · p_{fs} = Pressure increase



AC axial fan

sickle-shaped blades (S series)

Fan housing with guard grille

Curves: Air performance 60 Hz

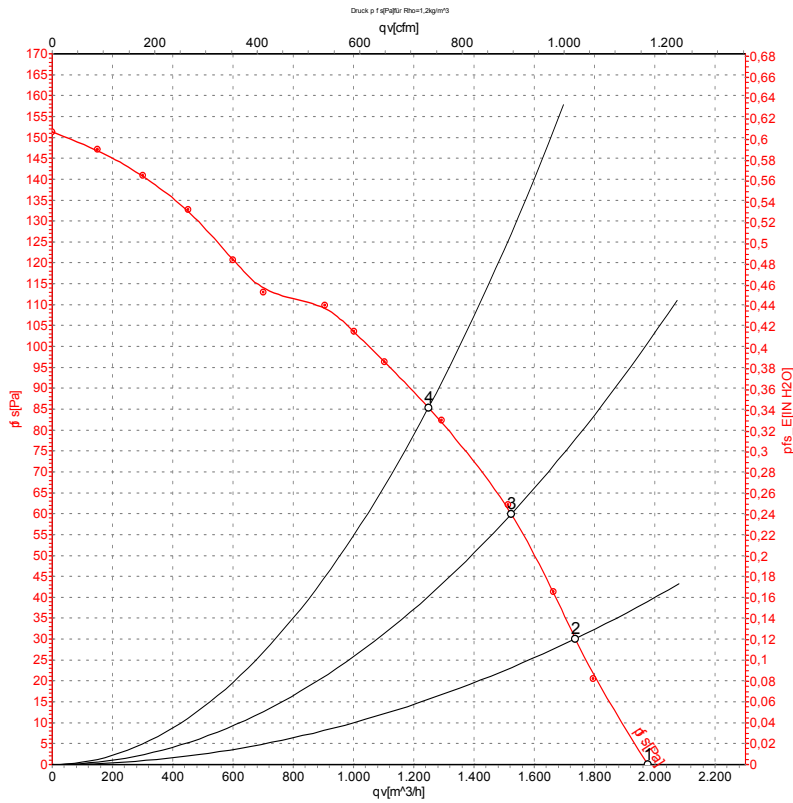

Measurement: LU-59609

Air performance measured according to ISO 5801 installation category A. For detailed information on the measurement setup, contact ebmpapst. Intake sound level: Sound power level according to ISO 13347 / sound pressure level measured at 1 m distance from fan axis. The values given are valid under the specified measuring conditions and may vary due to conditions of installation. For deviations from the standard configuration, the parameters have to be checked on the installed unit.

Measured values

	U	f	n	P_e	I	q_v	p_{fs}
	V	Hz	min ⁻¹	W	A	m³/h	Pa
1	230	60	2600	150	0.66	1970	0
2	230	60	2525	156	0.68	1735	30
3	230	60	2415	160	0.70	1525	60
4	230	60	2300	164	0.71	1250	85

U = Power supply · f = Frequency · n = Speed · P_e = Power consumption · I = Current draw · q_v = Air flow · p_{fs} = Pressure increase

