

W2E143-AA15-92 ebmpapst Datasheet
 sales@fansco.com
 www.fansco.com

Limited partnership · Headquarters Mulfingen
 Amtsgericht (court of registration) Stuttgart · HRA 590344
 General partner Elektrobau Mulfingen GmbH · Headquarters Mulfingen
 Amtsgericht (court of registration) Stuttgart · HRB 590142

Nominal data

Type	W2E143-AA15-92			
Motor	M2E052-BF			
Phase		1~	1~	1~
Nominal voltage	VAC	115	115	115
Frequency	Hz	50	60	60
Method of obtaining data		fa	fa	fa
Valid for approval/standard		CE	UL	CE
Speed (rpm)	min ⁻¹	2800	3300	3300
Power consumption	W	24	28	26
Current draw	A	0.25		0.23
Capacitor	µF	3	3	3
Capacitor voltage	VDB	250	250	250
Capacitor standard		S0 (CE)	UL	S0 (CE)
Min. ambient temperature	°C	-25	-25	-25
Max. ambient temperature	°C	70	70	70

ml = Max. load · me = Max. efficiency · fa = Free air · cs = Customer specification · ce = Customer equipment
 Subject to change



Technical description

Weight	0.96 kg
Size	143 mm
Motor size	52
Rotor surface	Painted black
Blade material	Sheet steel, painted black
Housing material	Sheet steel, painted black
Number of blades	5
Airflow direction	V
Direction of rotation	Counterclockwise, viewed toward rotor
Degree of protection	IP20
Insulation class	"B"
Moisture (F) / Environmental (H) protection class	H0+
Max. permitted ambient temp. for motor (transport/storage)	+ 80 °C
Min. permitted ambient temp. for motor (transport/storage)	- 40 °C
Installation position	Any
Condensation drainage holes	None
Mode	S1
Motor bearing	Ball bearing
Touch current according to IEC 60990 (measuring circuit Fig. 4, TN system)	< 0.75 mA
Motor protection	Thermal overload protector (TOP) internally connected
Protection class	I (with customer connection of protective earth)
Motor capacitor according to EN 60252-1 in safety protection class	S0
Conformity with standards	EN 60335-1; CE
Approval	CCC; CSA C22.2 No. 77; UL 1004-3



Product drawing

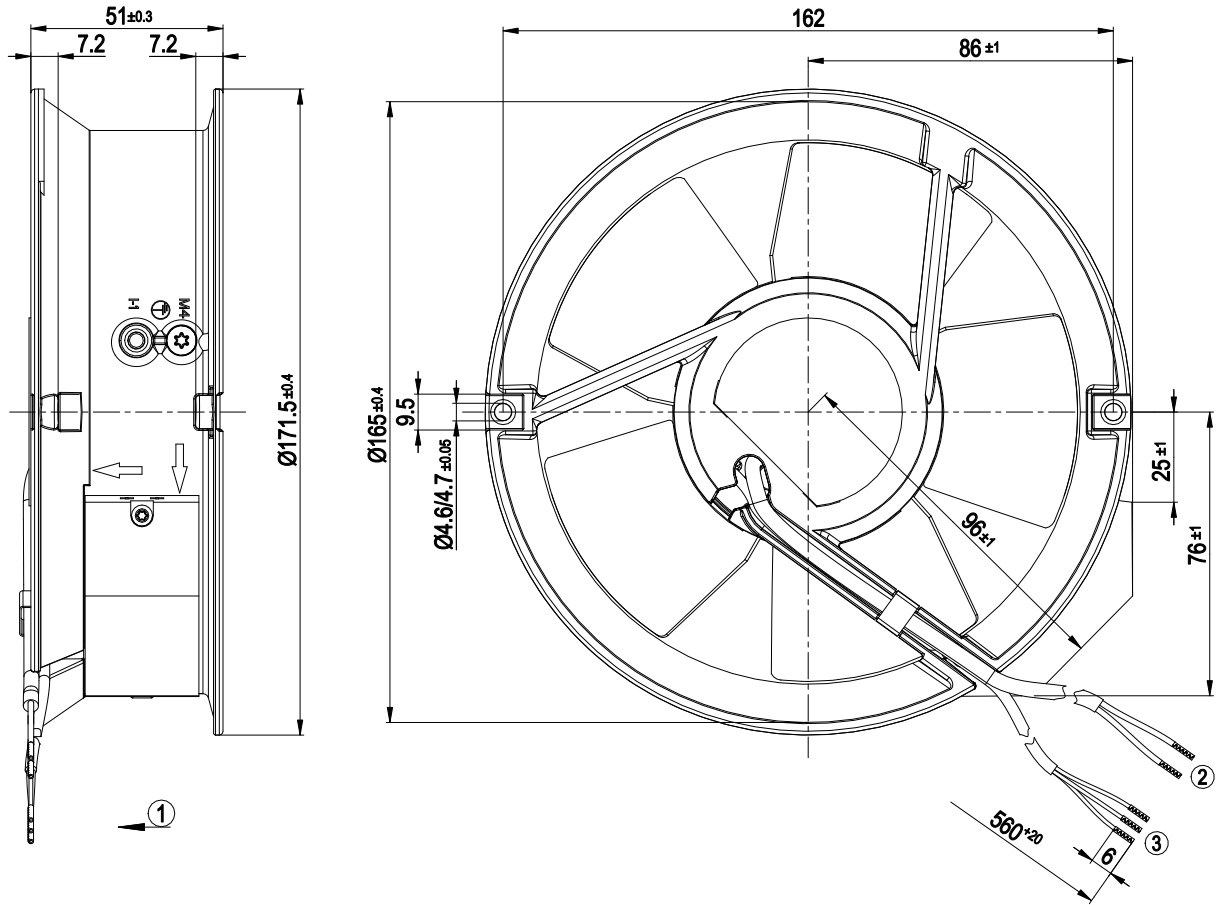

1	Direction of air flow "V"
2	Cable 2X AWG22, 2x crimped splices
3	Cable Hall IC 3X AWG26 AWG26, 3x crimped splices



Connection diagram

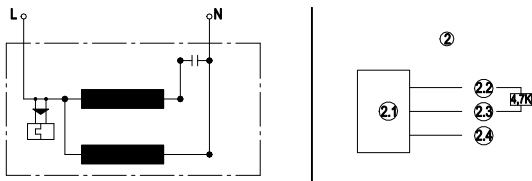

1	Fan connection diagram
L	blue
N	black
2	Hall IC circuit
2.1	Hall IC
2.2	Red (+5 V)
2.3	White (out)
2.4	Black (0 V)

Curves: Air performance 50 Hz

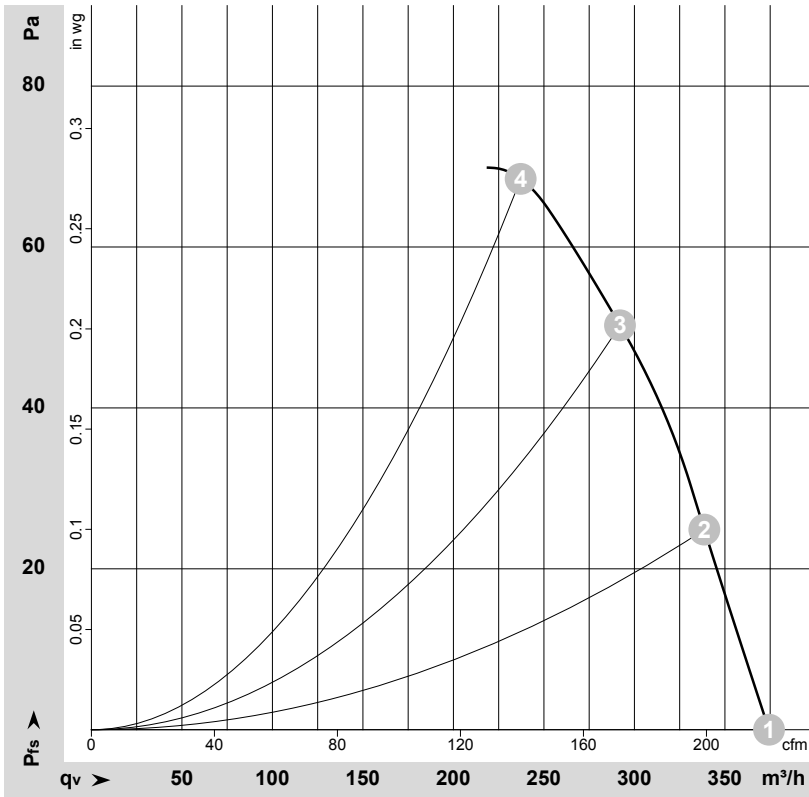

$\rho = 1.15 \text{ kg/m}^3 \pm 2 \%$

Measurement: LU-28180-1

Air performance measured according to ISO 5801 installation category A. For detailed information on the measurement setup, contact ebmpapst. Intake sound level: Sound power level according to ISO 13347 / sound pressure level measured at 1 m distance from fan axis. The values given are valid under the specified measuring conditions and may vary due to conditions of installation. For deviations from the standard configuration, the parameters have to be checked on the installed unit.

Measured values

	U	f	n	P _e	I	q _v	P _{fs}	q _v	P _{fs}
	V	Hz	min ⁻¹	W	A	m ³ /h	Pa	cfm	in. wg
1	115	50	2800	24	0.25	375	0	220	0.00
2	115	50	2850	25	0.25	340	25	200	0.10
3	115	50	2825	26	0.25	290	50	170	0.20
4	115	50	2815	27	0.25	235	70	140	0.28

U = Voltage · f = Frequency · n = Speed (rpm) · P_e = Power consumption · I = Current draw · q_v = Air flow · P_{fs} = Pressure increase



Curves: Air performance 60 Hz

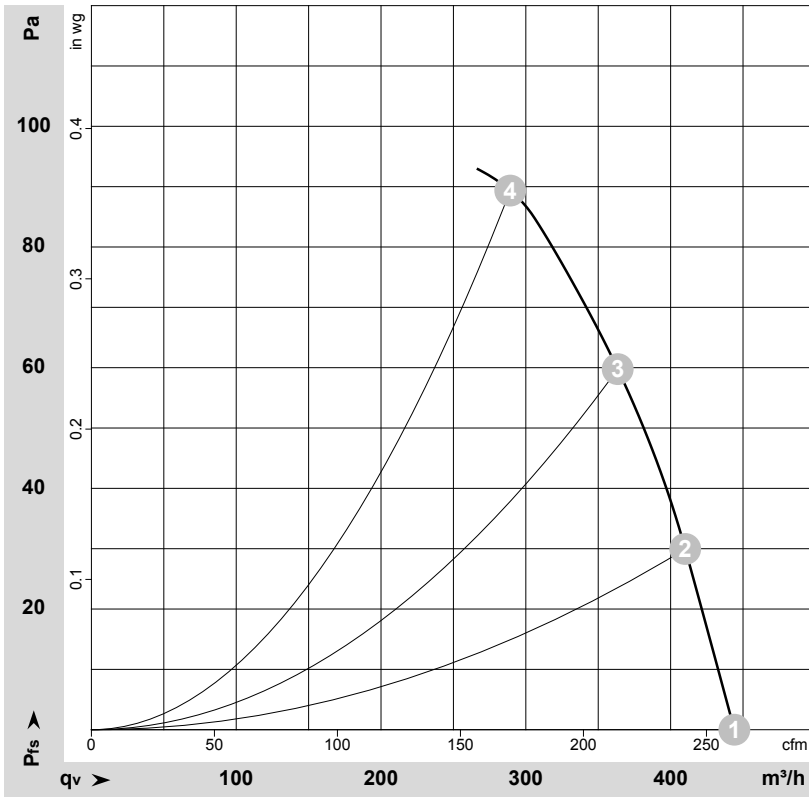

$\rho = 1.15 \text{ kg/m}^3 \pm 2 \%$

Measurement: LU-28191-1

Air performance measured according to ISO 5801 installation category A. For detailed information on the measurement setup, contact ebm-papst. Intake sound level: Sound power level according to ISO 13347 / sound pressure level measured at 1 m distance from fan axis. The values given are valid under the specified measuring conditions and may vary due to conditions of installation. For deviations from the standard configuration, the parameters have to be checked on the installed unit.

Measured values

	U	f	n	P _e	I	q _v	p _{fs}	q _v	p _{fs}
	V	Hz	min ⁻¹	W	A	m ³ /h	Pa	cfm	in. wg
1	115	60	3300	26	0.23	445	0	260	0.00
2	115	60	3340	28	0.24	410	30	240	0.12
3	115	60	3315	29	0.25	365	60	215	0.24
4	115	60	3270	30	0.27	290	90	170	0.36

U = Voltage · f = Frequency · n = Speed (rpm) · P_e = Power consumption · I = Current draw · q_v = Air flow · p_{fs} = Pressure increase

