

AC axial fan

sickle-shaped blades (S series)

with round full nozzle

W2D300-CP02-31 ebmpapst Datasheet

sales@fansco.com

www.fansco.com

Nominal data

| | | | | | |
|-----------------------------|-------------------|----------|----------|------|------|
| Type | W2D300-CP02-31 | | | | |
| Motor | M2D074-DF | | | | |
| Phase | | 3~ | 3~ | 3~ | 3~ |
| Nominal voltage | VAC | 230 | 230 | 400 | 400 |
| Wiring | | Δ | Δ | Y | Y |
| Frequency | Hz | 50 | 60 | 50 | 60 |
| Method of obtaining data | | fa | fa | fa | fa |
| Valid for approval/standard | | CE | CE | CE | CE |
| Speed (rpm) | min ⁻¹ | 2580 | 2750 | 2580 | 2750 |
| Power consumption | W | 210 | 300 | 210 | 300 |
| Current draw | A | 0.62 | 0.84 | 0.36 | 0.48 |
| Max. back pressure | Pa | 200 | 125 | 200 | 125 |
| Max. back pressure | in. wg | 0.8 | 0.5 | 0.8 | 0.5 |
| Min. ambient temperature | °C | -25 | -25 | -25 | -25 |
| Max. ambient temperature | °C | 75 | 40 | 75 | 40 |
| Starting current | A | 2.0 | 1.9 | 1.16 | 1.1 |

ml = Max. load · me = Max. efficiency · fa = Free air · cs = Customer specification · ce = Customer equipment
Subject to change

Data according to Commission Regulation (EU) 327/2011 (EN 17166)

| | | Actual | Req. 2015 | | | |
|-----------------------------------|---|--------|-----------|-------------------------------|-------------------|------|
| 01 Overall efficiency η_{es} | % | 32 | 29.8 | 09 Power consumption P_e | kW | 0.24 |
| 02 Measurement category | | A | | 09 Air flow q_v | m ³ /h | 2255 |
| 03 Efficiency category | | Static | | 09 Pressure increase p_{fs} | Pa | 127 |
| 04 Efficiency grade N | | 42.2 | 40 | 10 Speed (rpm) n | min ⁻¹ | 2485 |
| 05 Variable speed drive | | No | | 11 Specific ratio* | | 1.00 |

Data obtained at optimum efficiency level.
The ErP data is determined using a motor-impeller combination in a standardized measurement setup.

* Specific ratio = $1 + p_{fs} / 100\,000\text{ Pa}$

LU-189127



AC axial fan

sickle-shaped blades (S series)

with round full nozzle

Technical description

| | |
|--|--|
| Weight | 5.28 kg |
| Size | 300 mm |
| Motor size | 74 |
| Rotor surface | Painted black |
| Blade material | Sheet steel, painted black |
| Fan housing material | Sheet steel, pre-galvanized and coated with black plastic (RAL 9005) |
| Guard grille material | Steel, coated with black plastic (RAL 9005) |
| Number of blades | 5 |
| Airflow direction | A |
| Direction of rotation | Clockwise, viewed toward rotor |
| Degree of protection | IP44; installation- and position-dependent as per EN 60034-5 |
| Insulation class | "F" |
| Moisture (F) / Environmental (H) protection class | H1 |
| Max. permitted ambient temp. for motor (transport/storage) | + 80 °C |
| Min. permitted ambient temp. for motor (transport/storage) | - 40 °C |
| Installation position | Shaft horizontal or rotor on bottom; rotor on top on request |
| Condensation drainage holes | On rotor side |
| Mode | S1 |
| Motor bearing | Ball bearing |
| Touch current according to IEC 60990 (measuring circuit Fig. 4, TN system) | < 0.75 mA |
| With cable | Variable |
| Protection class | I (with customer connection of protective earth) |
| Conformity with standards | EN 60335-1; CE |
| Approval | EAC; CCC |



AC axial fan

sickle-shaped blades (S series)
with round full nozzle

Product drawing

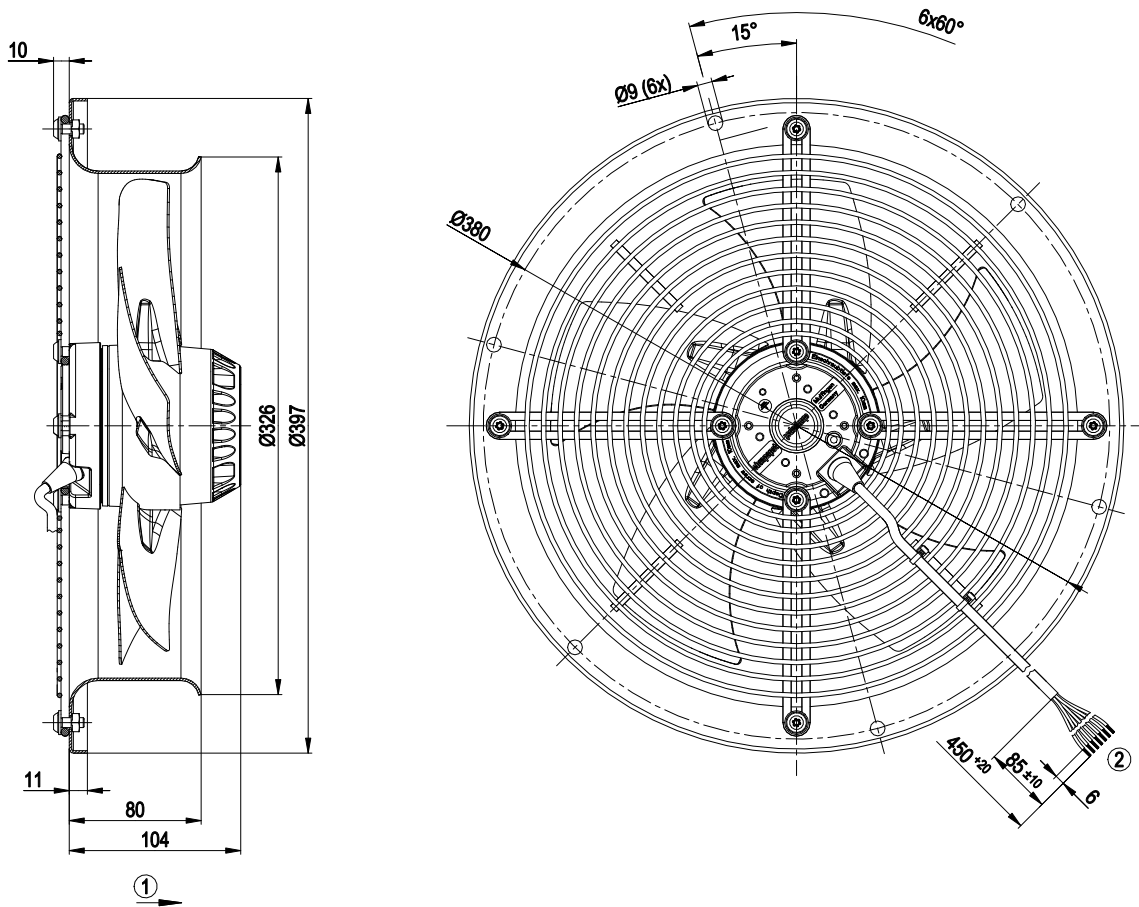

- | | |
|---|---|
| 1 | Direction of air flow "A" |
| 2 | Cable PFA AWG20 (gn/ye AWG18), 7x crimped splices |



AC axial fan

sickle-shaped blades (S series)

with round full nozzle

Connection diagram

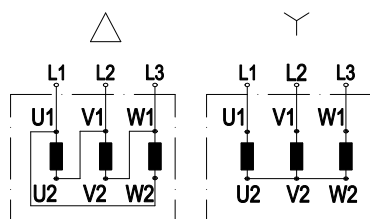

Change of rotation direction by reversing two phases

| | | | | | |
|----|-------------------|----|------------------|----|-----------------|
| | Three-phase motor | Δ | Delta connection | Y | Star connection |
| L1 | = U1 = black | L2 | = V1 = blue | L3 | = W1 = brown |
| U2 | green | V2 | white | W2 | yellow |

AC axial fan

sickle-shaped blades (S series)
with round full nozzle

Curves: Air performance 50 Hz

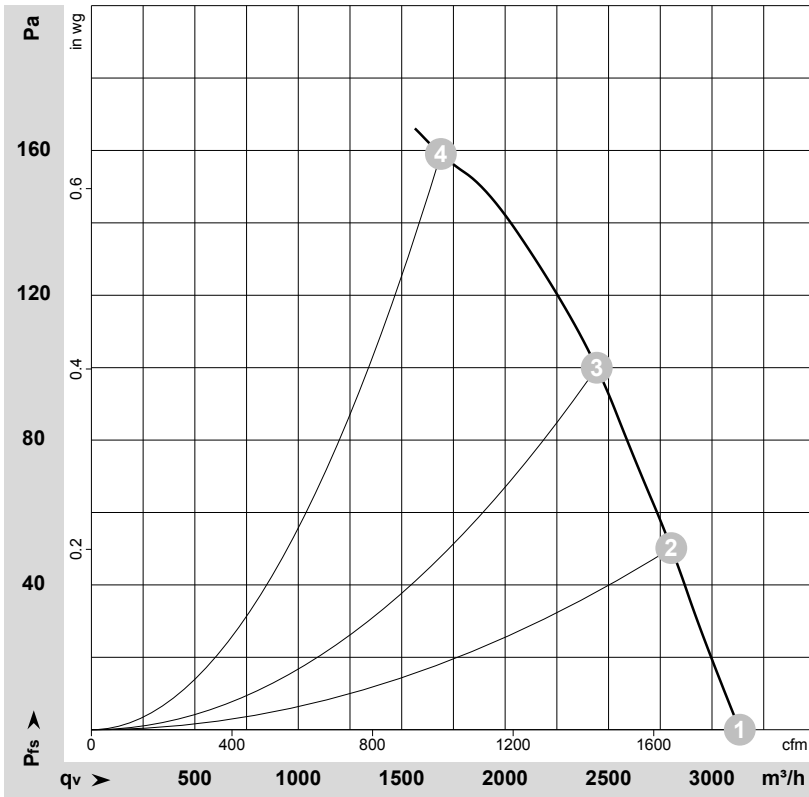

$\rho = 1.15 \text{ kg/m}^3 \pm 2 \%$

Measurement: LU-62732-1

Air performance measured according to ISO 5801 installation category A. For detailed information on the measurement setup, contact ebmpapst. Intake sound level: Sound power level according to ISO 13347 / sound pressure level measured at 1 m distance from fan axis. The values given are valid under the specified measuring conditions and may vary due to conditions of installation. For deviations from the standard configuration, the parameters have to be checked on the installed unit.

Measured values

| | Wired | U | f | n | P _e | I | q _v | P _{fs} | q _v | P _{fs} |
|---|-------|-----|----|-------------------|----------------|------|-------------------|-----------------|----------------|-----------------|
| | | V | Hz | min ⁻¹ | W | A | m ³ /h | Pa | cfm | in. wg |
| 1 | Y | 400 | 50 | 2580 | 210 | 0.36 | 3135 | 0 | 1845 | 0.00 |
| 2 | Y | 400 | 50 | 2540 | 228 | 0.36 | 2805 | 50 | 1650 | 0.20 |
| 3 | Y | 400 | 50 | 2490 | 244 | 0.39 | 2445 | 100 | 1440 | 0.40 |
| 4 | Y | 400 | 50 | 2385 | 281 | 0.44 | 1690 | 160 | 995 | 0.64 |

Wired = Wiring · U = Voltage · f = Frequency · n = Speed (rpm) · P_e = Power consumption · I = Current draw · q_v = Air flow · P_{fs} = Pressure increase



AC axial fan

sickle-shaped blades (S series)
with round full nozzle

Curves: Air performance 60 Hz

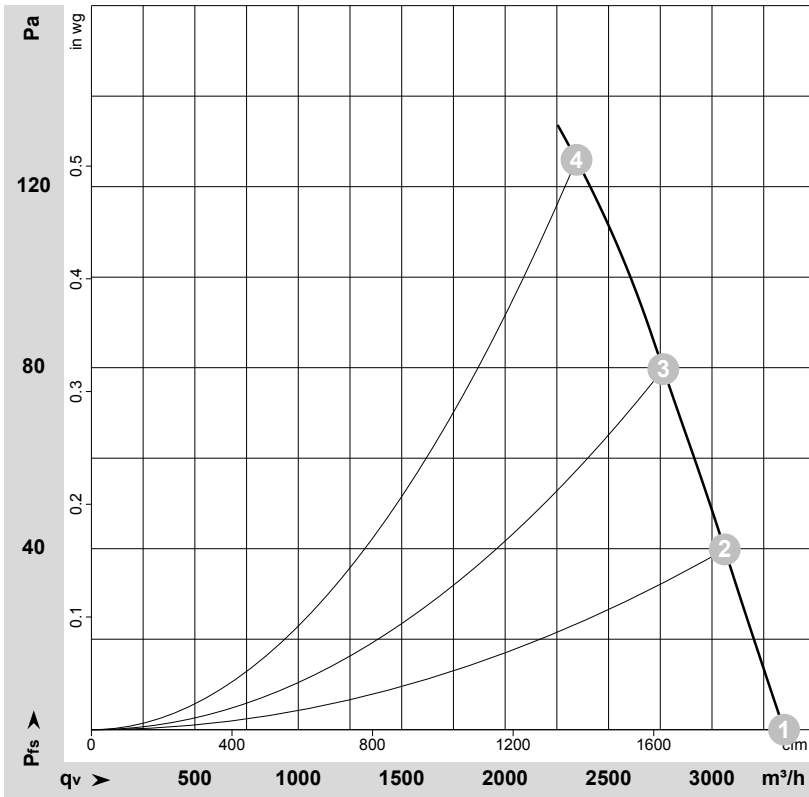

$\rho = 1.15 \text{ kg/m}^3 \pm 2 \%$

Measurement: LU-62733-1

Air performance measured according to ISO 5801 installation category A. For detailed information on the measurement setup, contact ebmpapst. Intake sound level: Sound power level according to ISO 13347 / sound pressure level measured at 1 m distance from fan axis. The values given are valid under the specified measuring conditions and may vary due to conditions of installation. For deviations from the standard configuration, the parameters have to be checked on the installed unit.

Measured values

| | U | f | n | P _e | I | q _v | P _{fs} | q _v | P _{fs} |
|---|-----|----|-------------------|----------------|------|-------------------|-----------------|----------------|-----------------|
| | V | Hz | min ⁻¹ | W | A | m ³ /h | Pa | cfm | in. wg |
| 1 | 400 | 60 | 2750 | 300 | 0.48 | 3350 | 0 | 1970 | 0.00 |
| 2 | 400 | 60 | 2685 | 316 | 0.48 | 3060 | 40 | 1800 | 0.16 |
| 3 | 400 | 60 | 2625 | 331 | 0.50 | 2765 | 80 | 1625 | 0.32 |
| 4 | 400 | 60 | 2540 | 349 | 0.53 | 2345 | 125 | 1380 | 0.50 |

U = Voltage · f = Frequency · n = Speed (rpm) · P_e = Power consumption · I = Current draw · q_v = Air flow · P_{fs} = Pressure increase

