

# EC axial fan

with brushless DC motor

Automotive



W1G300-EC12-06 ebmpapst Datasheet

sales@fansco.com

www.fansco.com

Limited partnership · Headquarters Mulfingen  
 Amtsgericht (court of registration) Stuttgart · HRA 590344

General partner Elektrobau Mulfingen GmbH · Headquarters Mulfingen  
 Amtsgericht (court of registration) Stuttgart · HRB 590142

## Nominal data

Type	W1G300-EC12-06	
Motor	M1G074-CF	
Nominal voltage	VDC	12
Nominal voltage range	VDC	9 .. 16
Method of obtaining data		fa
Speed (rpm)	min <sup>-1</sup>	2490
Power consumption	W	135
Current draw	A	11.0
Min. ambient temperature	°C	-40
Max. ambient temperature	°C	70
-with power derating to	°C	85

ml = Max. load · me = Max. efficiency · fa = Free air · cs = Customer specification · ce = Customer equipment  
 Subject to change

## Data according to Commission Regulation (EU) 327/2011

		Actual	Req. 2015
01 Overall efficiency $\eta_{es}$	%	41.2	28.2
02 Measurement category		A	
03 Efficiency category		Static	
04 Efficiency grade N		53	40
05 Variable speed drive		Yes	

Data obtained at optimum efficiency level.  
 The ErP data is determined using a motor-impeller combination in a standardized measurement setup.

09 Power consumption $P_e$	kW	0.13
09 Air flow $q_v$	m <sup>3</sup> /h	1205
09 Pressure increase $p_{fs}$	Pa	147
10 Speed (rpm) n	min <sup>-1</sup>	2370
11 Specific ratio*		1.00

\* Specific ratio =  $1 + p_s / 100\,000\text{ Pa}$

LU-177508



## Technical description

Weight	2.6 kg
Size	300 mm
Motor size	74
Electronics housing material	Die-cast aluminum, painted black
Impeller material	PA6 plastic
Housing material	Die-cast aluminum
Fan housing material	PP plastic
Number of blades	5
Motor suspension	Motor vibration-damped on both sides
Airflow direction	V
Direction of rotation	Clockwise, viewed toward rotor
Degree of protection	Motor IP24 KM, electronics IP6K9K (mating connector installed)
Insulation class	"B"
Moisture (F) / Environmental (H) protection class	H4
Ambient temperature note	Above +70°C with power derating; External sources of heat above 85°C can affect the service life
Max. permitted ambient temp. for motor (transport/storage)	+80 °C
Min. permitted ambient temp. for motor (transport/storage)	-40 °C
Installation position	Any
Condensation drainage holes	None, open rotor
Cooling hole/opening	On rotor side
Mode	S1
Motor bearing	Ball bearing
Technical features	<ul style="list-style-type: none"> <li>- Motor current limitation</li> <li>- Soft start</li> <li>- Control input 0-10 VDC / PWM</li> <li>- Temperature derating</li> <li>- Thermal overload protection for electronics</li> <li>- Reverse polarity protection</li> </ul>
Speed levels	2
Electrical hookup	Plug
Motor protection	Locked-rotor protection
Approval	EAC
Comment	E1 approval in preparation

# EC axial fan

with brushless DC motor

Automotive

## Product drawing

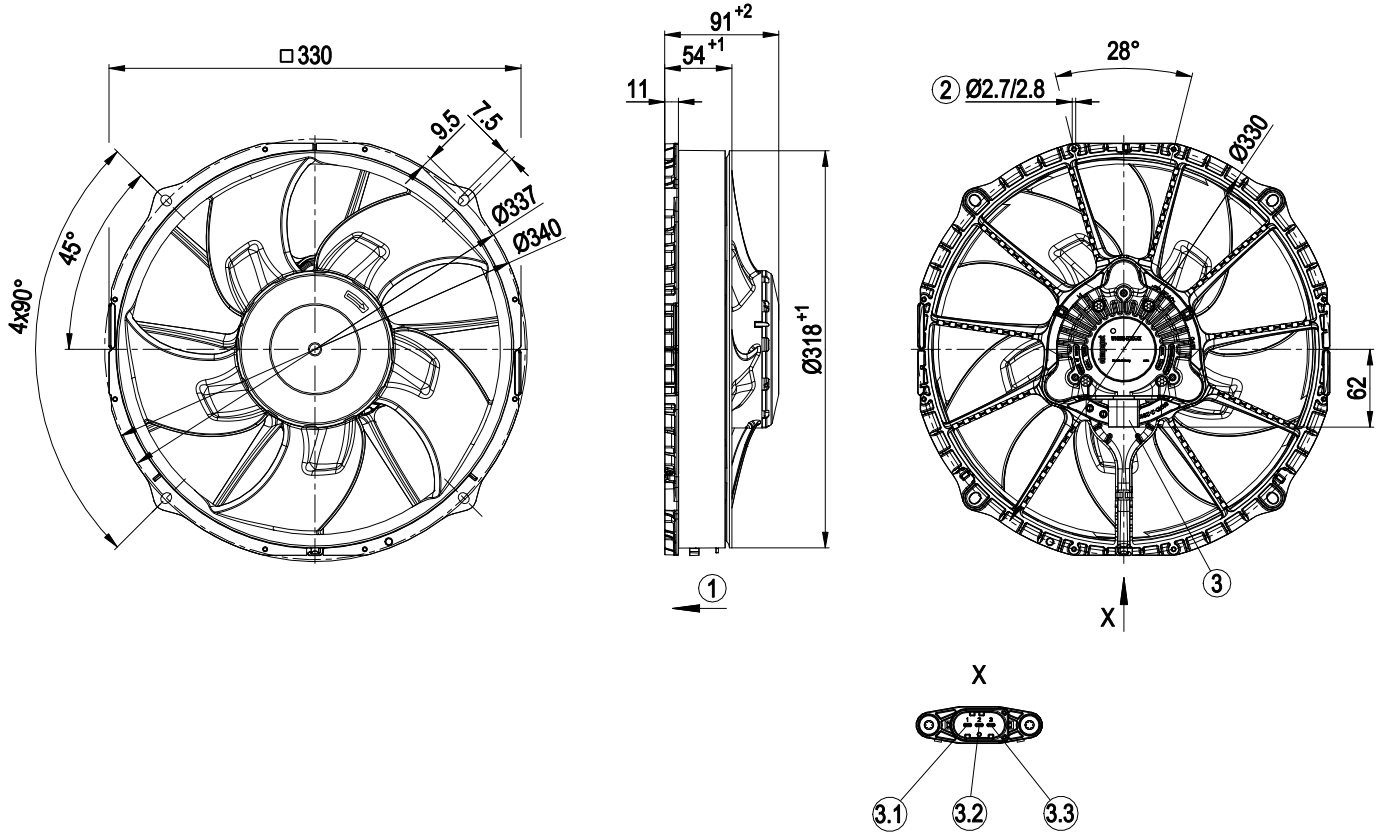

1	Airflow direction "V"
2	on both sides for screws for fastening plastics, Ø 3.5 mm
3	Plug TE MCP 2.8, 3-pole, coded
3.1	+ UB
3.2	0-10 V
3.3	GND
Accessory part: Cable (420 mm) with mating connector, part no. 02020-4-1021 not included in scope of delivery 3-pole mating connector TE 1-1718627-1, 2x socket TE 1241396-1, 1x socket TE 1241388-1, 2x seal TE 963292-1, 1x seal TE 963294-1	



# EC axial fan

with brushless DC motor  
Automotive

## Connection diagram

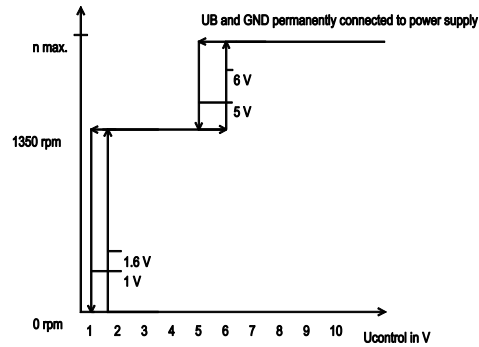
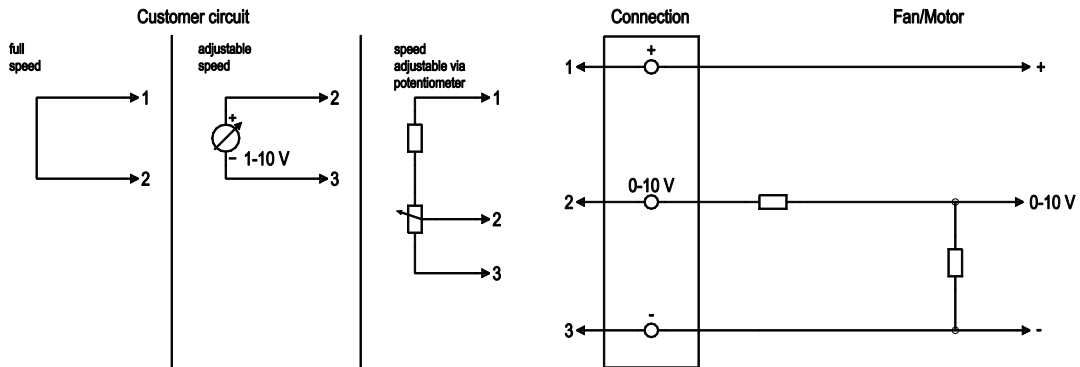

No.	Conn.	Designation	Function/assignment
1	1	UN +13 VDC	Power supply 13 VDC, maximum ripple 3.5%
2	2	PWM/LIN	Control input, 2 speed levels 0-10 V or PWM (1-10 kHz with 10 V level)
3	3	GND	Reference ground



## Curves: Air performance

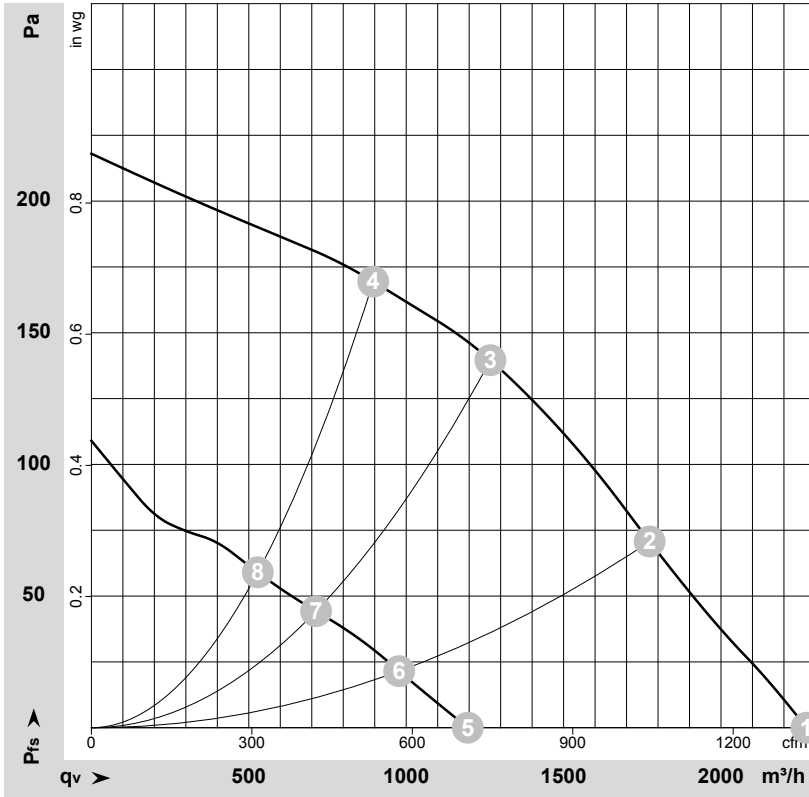

$\rho = 1.15 \text{ kg/m}^3 \pm 2 \%$

Measurement: LU-177508-1

Air performance measured according to ISO 5801 installation category A. For detailed information on the measurement setup, contact ebmpapst. Intake sound level: Sound power level according to ISO 13347 / sound pressure level measured at 1 m distance from fan axis. The values given are valid under the specified measuring conditions and may vary due to conditions of installation. For deviations from the standard configuration, the parameters have to be checked on the installed unit.

## Measured values

	U	n	P <sub>ed</sub>	I	LpA <sub>in</sub>	LwA <sub>in</sub>	q <sub>v</sub>	P <sub>fs</sub>	q <sub>v</sub>	P <sub>fs</sub>
	V	min <sup>-1</sup>	W	A	dB(A)	dB(A)	m <sup>3</sup> /h	Pa	cfm	in. wg
1	12	2490	135	11.00	69	76	2270	0	1335	0.00
2	12	2400	135	11.27	70	78	1775	70	1045	0.28
3	12	2375	137	11.33	70	78	1265	140	745	0.56
4	12	2275	137	11.36	71	79	895	170	525	0.68
5	12	1350	24	1.96	54	60	1195	0	705	0.00
6	12	1350	26	2.15	55	63	980	21	575	0.08
7	12	1350	28	2.30	56	64	715	44	420	0.18
8	12	1350	31	2.53	58	66	530	59	310	0.24

U = Voltage · n = Speed (rpm) · P<sub>ed</sub> = Power consumption · I = Current draw · LpA<sub>in</sub> = Sound pressure level intake side · LwA<sub>in</sub> = Sound power level intake side · q<sub>v</sub> = Air flow  
P<sub>fs</sub> = Pressure increase

