

EC axial fan - HyBlade

sickle-shaped blades (S series)

with round full nozzle

W1G300-DC33-52 ebmpapst Datasheet

sales@fansco.com

www.fansco.com

Limited partnership · Headquarters Muldingen

Amtsgericht (court of registration) Stuttgart · HRA 590344

General partner Elektrobau Muldingen GmbH · Headquarters Muldingen

Amtsgericht (court of registration) Stuttgart · HRB 590142

Nominal data

Type	W1G300-DC33-52	
Motor	M1G074-CF	
Nominal voltage	VDC	48
Nominal voltage range	VDC	36 .. 57
Method of obtaining data		fa
Speed (rpm)	min ⁻¹	1830
Power consumption	W	80
Current draw	A	1.9
Max. back pressure	Pa	100
Max. back pressure	in. wg	0.4
Min. ambient temperature	°C	-25
Max. ambient temperature	°C	60

ml = Max. load · me = Max. efficiency · fa = Free air · cs = Customer specification · ce = Customer equipment
Subject to change



EC axial fan - HyBlade

sickle-shaped blades (S series)

with round full nozzle

Technical description

Weight	3.8 kg
Size	300 mm
Motor size	74
Rotor surface	Painted black
Blade material	Press-fitted sheet steel blank, sprayed with PP plastic
Fan housing material	Sheet steel, galvanized and coated with black plastic (RAL 9005)
Guard grille material	Steel, coated with black plastic (RAL 9005)
Number of blades	5
Airflow direction	A
Direction of rotation	Clockwise, viewed toward rotor
Degree of protection	IP42
Insulation class	"B"
Moisture (F) / Environmental (H) protection class	F0; H0 - dry environment
Max. permitted ambient temp. for motor (transport/storage)	+80 °C
Min. permitted ambient temp. for motor (transport/storage)	-40 °C
Installation position	Any
Condensation drainage holes	None
Mode	S1
Motor bearing	Ball bearing
Technical features	<ul style="list-style-type: none"> - Tach output - Motor current limitation - Soft start - Control input 0-10 VDC / PWM
EMC immunity to interference	According to EN 61000-6-2 (industrial environment)
EMC interference emission	According to EN 55022 (Class B)
Motor protection	Reverse polarity and locked-rotor protection
With cable	Lateral
Conformity with standards	EN 60950-1
Approval	EAC; UL 1004-1; CSA C22.2 No. 77



EC axial fan - HyBlade

sickle-shaped blades (S series)

with round full nozzle

Product drawing

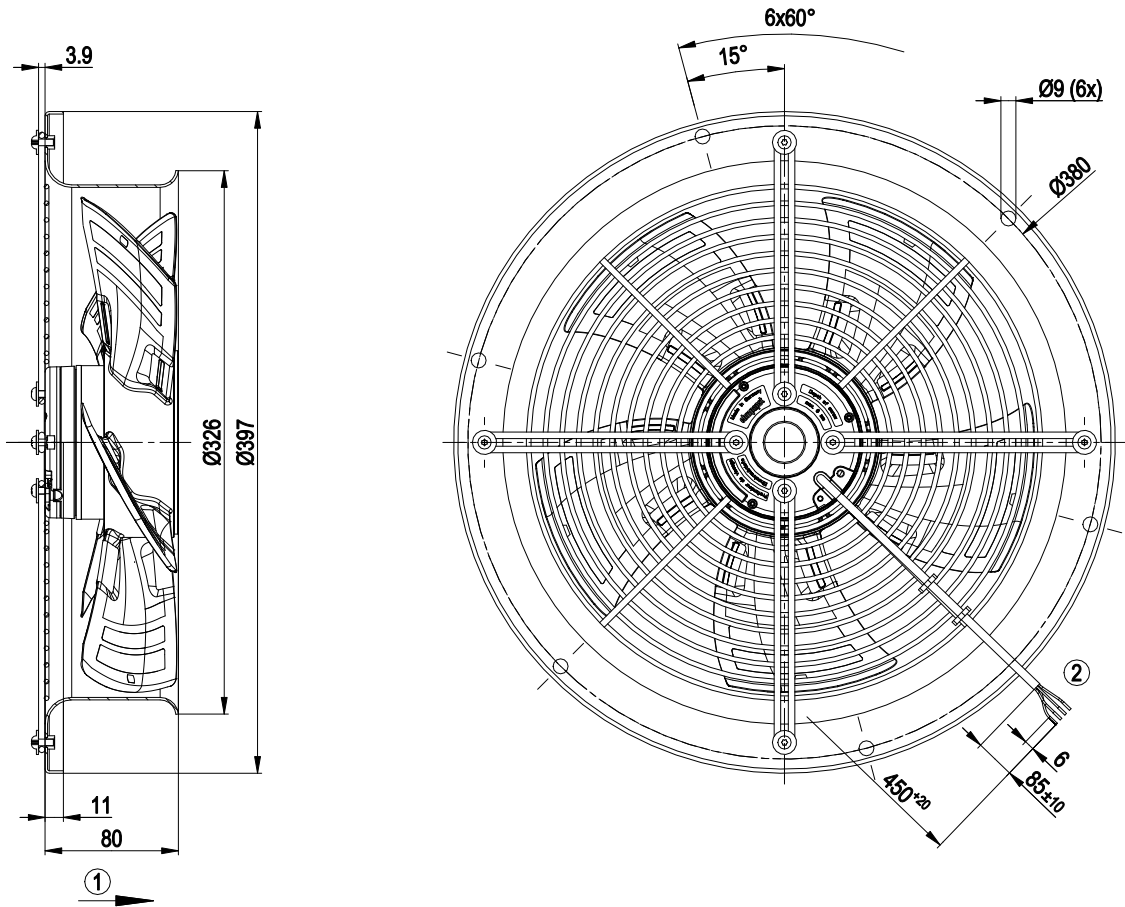

- 1 Direction of air flow "A"
- 2 Cable PVC AWG20, 4x crimped splices



EC axial fan - HyBlade

sickle-shaped blades (S series)

with round full nozzle

Connection diagram

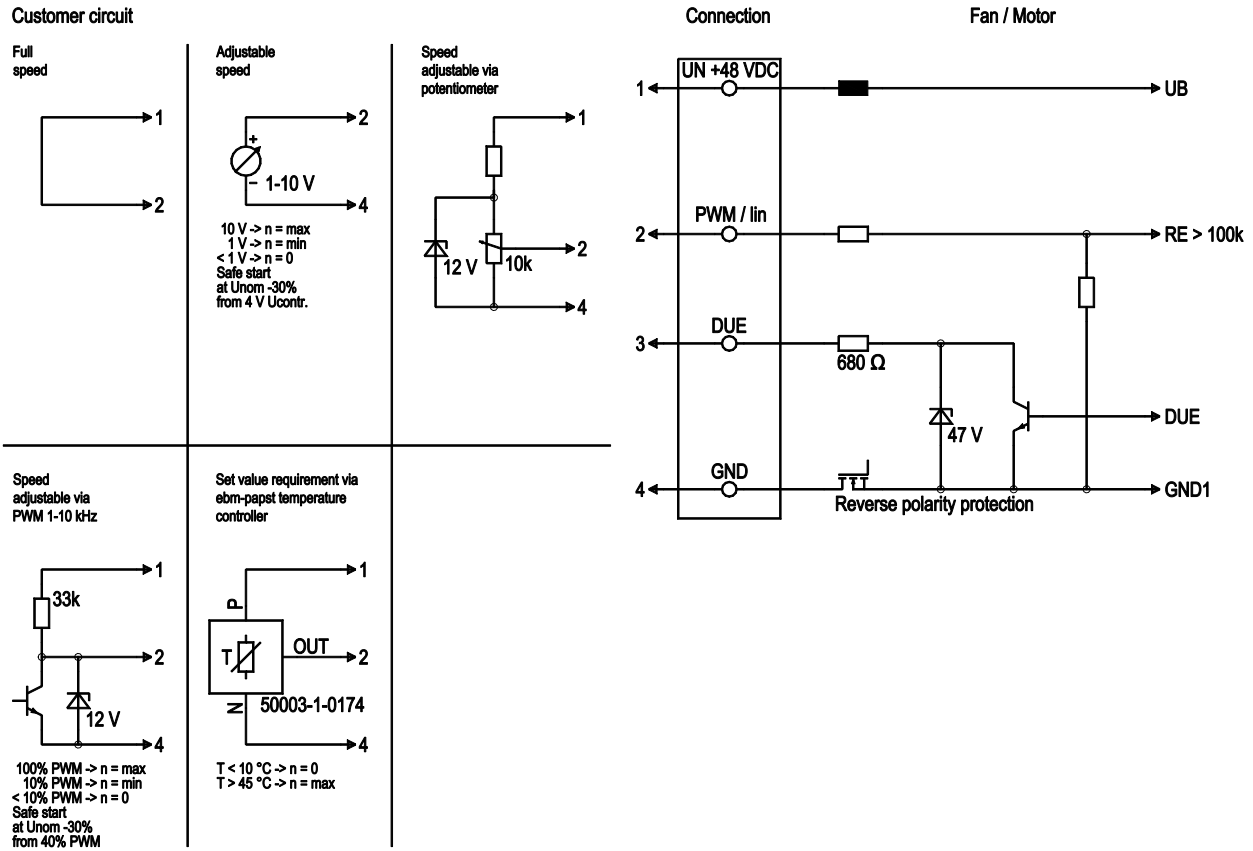

No.	Conn.	Designation	Color	Function/assignment
1	1	Un +48 VDC	red	Power supply 48 VDC, maximum ripple 3.5%
1	2	PWM / lin	yellow	PWM / lin. Control input 0-10 V
1	3	Tach	white	Tach output, 3 pulses per revolution, Isink max = 10 mA
1	4	GND	blue	Reference ground



Curves: Air performance

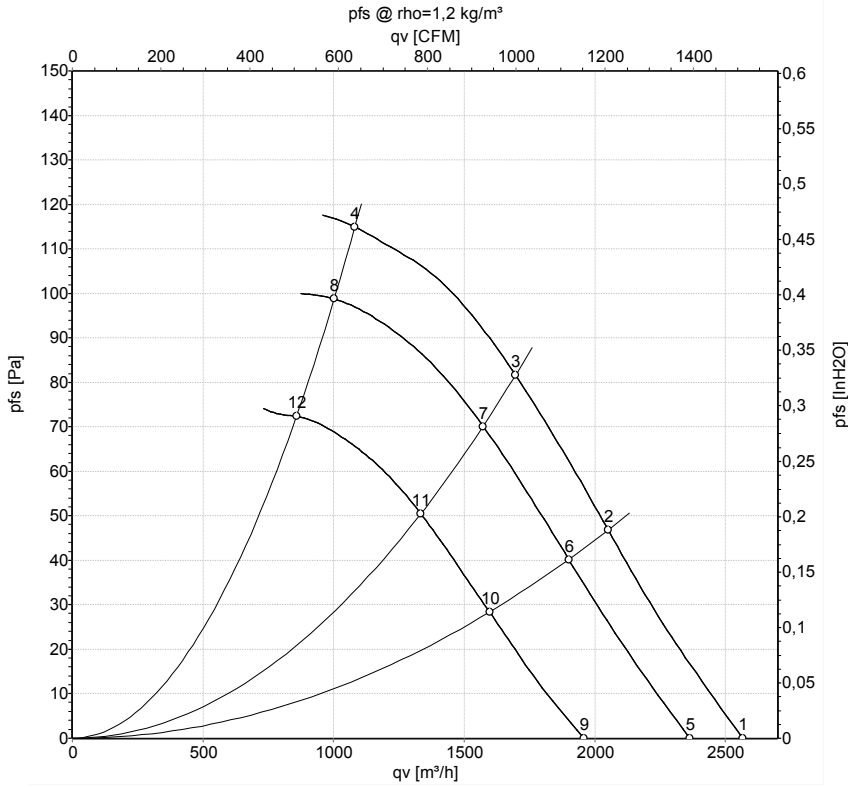

Measurement: LU-137645-1
 Measurement: LU-137650-1
 Measurement: LU-137644-1

Air performance measured according to ISO 5801 installation category A. For detailed information on the measurement setup, contact ebm-papst. Intake sound level: Sound power level according to ISO 13347 / sound pressure level measured at 1 m distance from fan axis. The values given are valid under the specified measuring conditions and may vary due to conditions of installation. For deviations from the standard configuration, the parameters have to be checked on the installed unit.

Measured values

	U	n	P _{ed}	I	LpA _{in}	LwA _{in}	q _v	P _{fs}	q _v	P _{fs}
	V	min ⁻¹	W	A	dB(A)	dB(A)	m ³ /h	Pa	cfm	in. wg
1	57	1985	103	2.05	62	69	2565	0	1510	0.00
2	57	1875	105	2.14	61	69	2050	47	1210	0.19
3	57	1820	107	2.20	60	68	1695	82	1000	0.33
4	57	1720	111	2.32	66	74	1080	115	635	0.46
5	48	1830	80	1.90	60	67	2365	0	1390	0.00
6	48	1735	84	1.97	60	68	1900	40	1120	0.16
7	48	1690	85	2.01	59	66	1575	70	925	0.28
8	48	1595	88	2.10	64	72	1000	100	590	0.40
9	36	1515	46	1.44	55	62	1960	0	1155	0.00
10	36	1455	50	1.56	55	63	1600	28	940	0.11
11	36	1430	52	1.62	54	62	1335	51	785	0.20
12	36	1375	56	1.74	59	67	860	72	505	0.29

U = Voltage · n = Speed (rpm) · P_{ed} = Power consumption · I = Current draw · LpA_{in} = Sound pressure level intake side · LwA_{in} = Sound power level intake side · q_v = Air flow
 P_{fs} = Pressure increase

