

W1G250-HJ63-02 ebmpapst Datasheet

sales@fansco.com

www.fansco.com

Limited partnership · Headquarters Muldingen

Amtsgericht (court of registration) Stuttgart · HRA 590344

General partner Elektrobau Muldingen GmbH · Headquarters Muldingen

Amtsgericht (court of registration) Stuttgart · HRB 590142

## Nominal data

Type	W1G250-HJ63-02	
Motor	M1G074-BF	
Nominal voltage	VDC	48
Nominal voltage range	VDC	36 .. 57
Method of obtaining data		fa
Speed (rpm)	min <sup>-1</sup>	3090
Power consumption	W	120
Current draw	A	3.4
Max. back pressure	Pa	150
Max. back pressure	inH <sub>2</sub> O	0.6
Min. ambient temperature	°C	-40
Max. ambient temperature	°C	60

ml = Max. load · me = Max. efficiency · fa = Free air · cs = Customer specification · ce = Customer equipment  
Subject to change



### Technical description

Weight	2.35 kg
Fan size	250 mm
Rotor surface	Galvanized
Electronics housing material	Die-cast aluminum, painted black
Impeller material	PP plastic
Fan housing material	Die-cast aluminum
Number of blades	7
Airflow direction	"V"
Direction of rotation	Counterclockwise, viewed toward rotor
Degree of protection	IP24 KM
Insulation class	"B"
Moisture (F) / Environmental (H) protection class	H2+
Ambient temperature note	Occasional start-up between -40°C and -25°C is permissible. For continuous operation at temperatures below -25°C (e.g. refrigeration applications) we recommend our fan design with special low-temperature bearings.
Max. permitted ambient temp. for motor (transport/storage)	+70 °C
Min. permitted ambient temp. for motor (transport/storage)	-40 °C
Installation position	Shaft horizontal or rotor on bottom; rotor on top on request
Condensation drainage holes	On rotor side
Mode	S1
Motor bearing	Ball bearing; (sealed)
Technical features	<ul style="list-style-type: none"> <li>- Tach output</li> <li>- Motor current limitation</li> <li>- Soft start</li> <li>- Control input 0-10 VDC / PWM</li> <li>- Overvoltage detection</li> <li>- Thermal overload protection for electronics</li> </ul>
Electrical hookup	Via terminal strip
Motor protection	Reverse polarity and locked-rotor protection
Approval	UL 507; EAC

## Product drawing

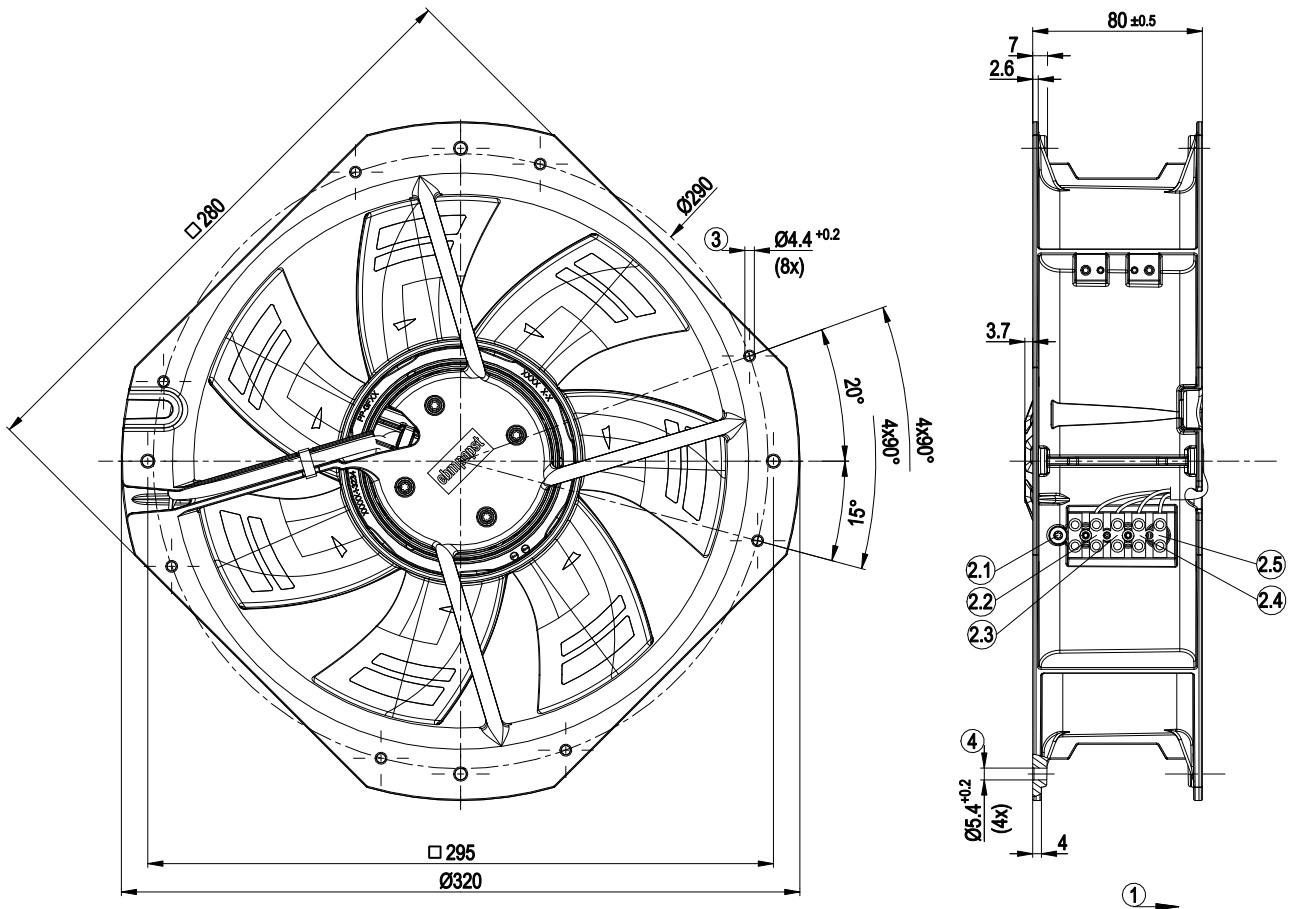

1	Direction of air flow "V"
2.1	Protective earth
2.2	Control input yellow
2.3	Speed monitoring white
2.4	(-) blue
2.5	(+) red
3	For self-tapping M5 screws
4	For self-tapping M6 screws

## Connection diagram

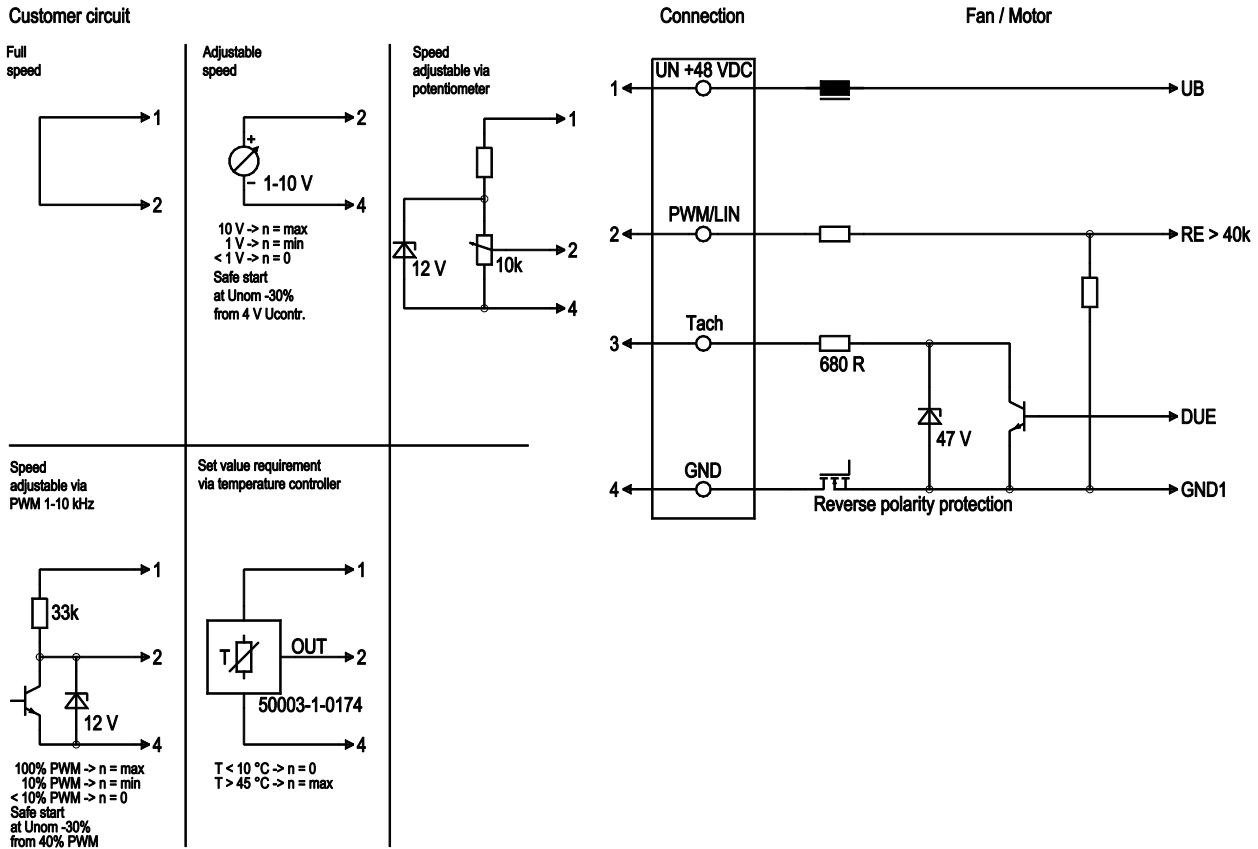

No.	Conn.	Designation	Color	Function/assignment
1	1	UN +48 VDC	red	Power supply 48 VDC, maximum ripple 3.5%
1	2	PWM/LIN	yellow	Control input Re > 100k
1	3	Tach	white	Tach output, 3 pulses per revolution, Isink max = 10 mA
1	4	GND	blue	Reference ground



## Curves: Air performance

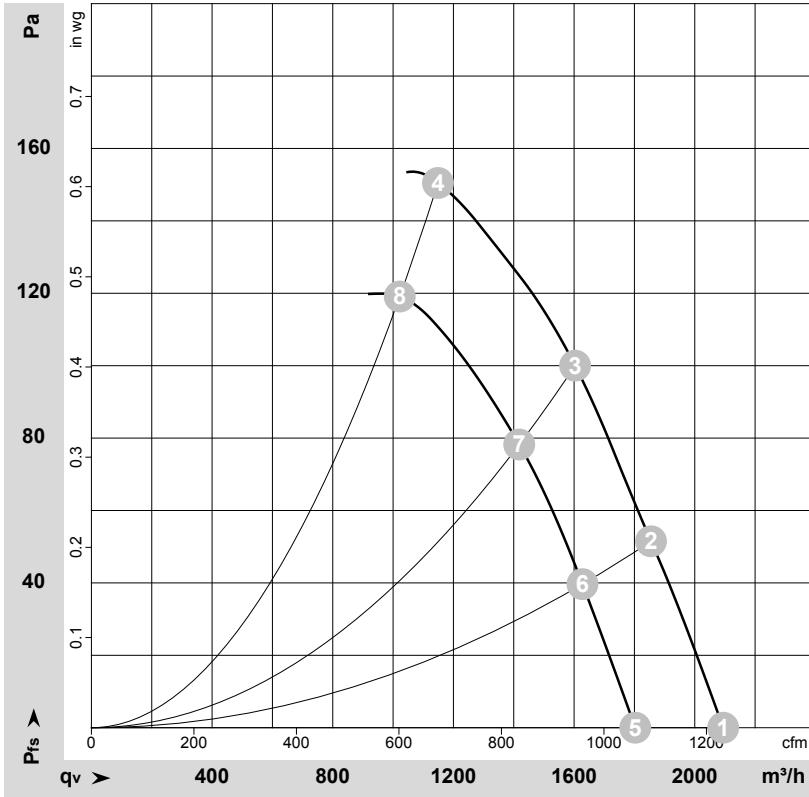

$\rho = 1.15 \text{ kg/m}^3 \pm 2 \%$

Measurement: LU-169648-1  
Measurement: LU-169680-1

Air performance measured according to ISO 5801 installation category A. For detailed information on the measurement setup, contact ebm-papst. Intake sound level: Sound power level according to ISO 13347 / sound pressure level measured at 1 m distance from fan axis. The values given are valid under the specified measuring conditions and may vary due to conditions of installation. For deviations from the standard configuration, the parameters have to be checked on the installed unit.

## Measured values

	U	n	P <sub>ed</sub>	I	q <sub>v</sub>	p <sub>fs</sub>	q <sub>v</sub>	p <sub>fs</sub>
	V	min <sup>-1</sup>	W	A	m <sup>3</sup> /h	Pa	cfm	inH <sub>2</sub> O
1	48-57	3090	120		2095	0	1230	0.00
2	48-57	2925	128		1855	50	1090	0.20
3	48-57	2800	131		1605	100	945	0.40
4	48-57	2715	133		1150	150	675	0.60
5	36	2660	78	2.94	1805	0	1060	0.00
6	36	2565	84	3.17	1630	40	960	0.16
7	36	2490	89	3.34	1420	78	835	0.31
8	36	2435	92	3.46	1020	120	600	0.48

U = Power supply · n = Speed (rpm) · P<sub>ed</sub> = Power consumption · I = Current draw · q<sub>v</sub> = Air flow · p<sub>fs</sub> = Pressure increase

