

W1G250-HH37-42 ebmpapst Datasheet

sales@fansco.com

www.fansco.com

Limited partnership · Headquarters Muldingen

Amtsgericht (court of registration) Stuttgart · HRA 590344

General partner Elektrobau Muldingen GmbH · Headquarters Muldingen

Amtsgericht (court of registration) Stuttgart · HRB 590142

## Nominal data

Type	W1G250-HH37-42	
Motor	M1G074-BF	
Nominal voltage	VDC	24
Nominal voltage range	VDC	16 .. 28
Method of obtaining data		fa
Speed (rpm)	min <sup>-1</sup>	2750
Power consumption	W	105
Current draw	A	5.0
Max. back pressure	Pa	140
Max. back pressure	inH <sub>2</sub> O	0.56
Min. ambient temperature	°C	-25
Max. ambient temperature	°C	50

ml = Max. load · me = Max. efficiency · fa = Free air · cs = Customer specification · ce = Customer equipment  
Subject to change



### Technical description

<b>Weight</b>	2.3 kg
<b>Fan size</b>	250 mm
<b>Rotor surface</b>	Painted black
<b>Blade material</b>	Sheet steel, painted black
<b>Fan housing material</b>	Die-cast aluminum
<b>Number of blades</b>	7
<b>Airflow direction</b>	"V"
<b>Direction of rotation</b>	Counterclockwise, viewed toward rotor
<b>Degree of protection</b>	IP42
<b>Insulation class</b>	"B"
<b>Moisture (F) / Environmental (H) protection class</b>	F3-1
<b>Max. permitted ambient temp. for motor (transport/storage)</b>	+80 °C
<b>Min. permitted ambient temp. for motor (transport/storage)</b>	-40 °C
<b>Installation position</b>	Any
<b>Condensation drainage holes</b>	On rotor side
<b>Mode</b>	S1
<b>Motor bearing</b>	Ball bearing
<b>Technical features</b>	<ul style="list-style-type: none"> <li>- Tach output</li> <li>- Motor current limitation</li> <li>- Soft start</li> <li>- Control input 0-10 VDC / PWM</li> </ul>
<b>EMC immunity to interference</b>	According to EN 61000-6-2 (industrial environment)
<b>EMC interference emission</b>	According to EN 55022 (Class B)
<b>Motor protection</b>	Reverse polarity and locked-rotor protection
<b>With cable</b>	Variable
<b>Conformity with standards</b>	EN 60950-1

Product drawing

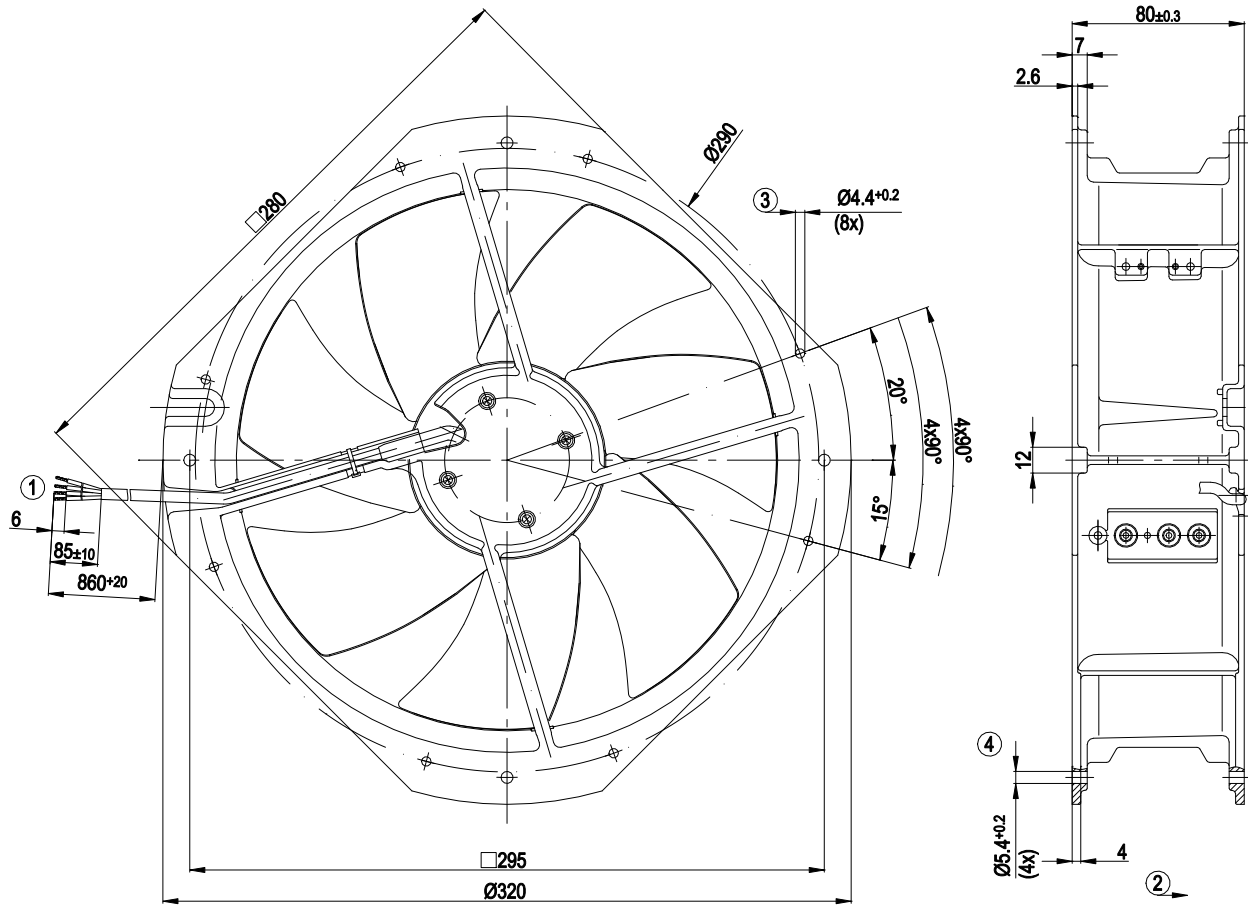

1	Cable halogen-free, 4x crimped splices
2	Direction of air flow "V"
3	For self-tapping M5 screws
4	For self-tapping M6 screws



## Connection diagram

### Customer circuit

Full speed

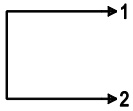

Adjustable speed

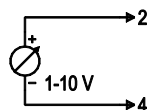

10 V → n = max  
1 V → n = min  
< 1 V → n = 0  
Safe start at Unom -30% from 4 V Ucontr.

Speed adjustable via potentiometer

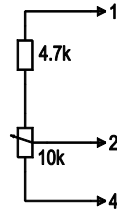

Speed adjustable via PWM 1-10 kHz

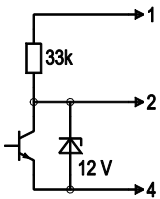

100% PWM → n = max  
10% PWM → n = min  
< 10% PWM → n = 0  
Safe start at Unom -30% from 40% PWM

Set value requirement via temperature controller

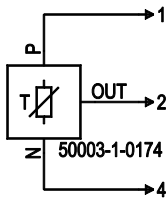

T < 10 °C → n = 0  
T > 45 °C → n = max

### Connection

### Fan / Motor

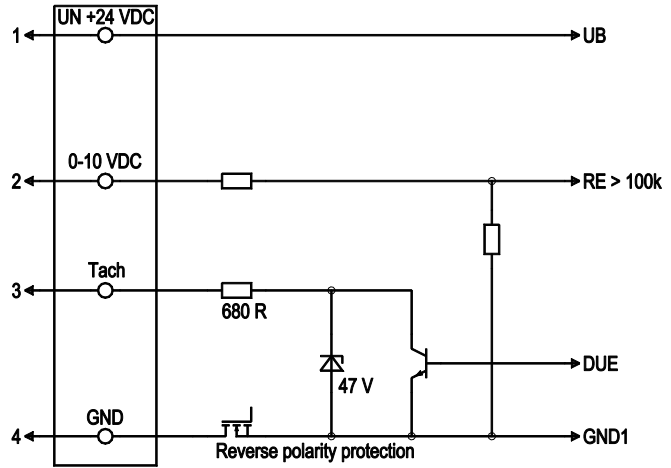

No.	Conn.	Designation	Color	Function/assignment
1	1	Un +24 VDC	red	Power supply 24 VDC, maximum ripple 3.5 %
1	2	0-10 VDC	yellow	Control input Re > 100k
1	3	Tach	white	Tach output, 3 pulses per revolution, Isink max = 10 mA
1	4	GND	blue	Reference ground



## Curves: Air performance

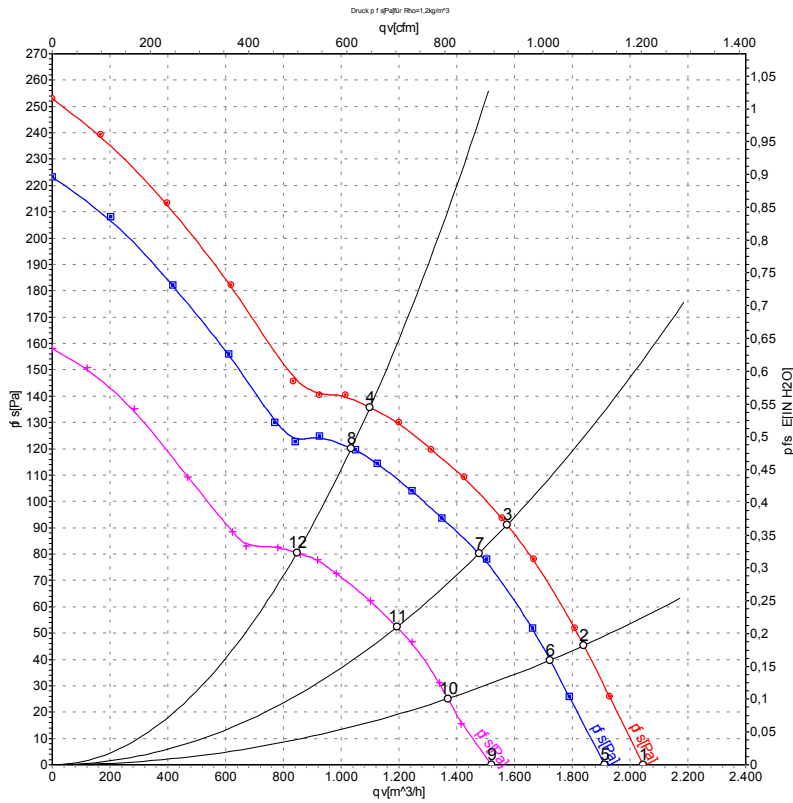

Measurement: LU-54187-1  
 Measurement: LU-54186-1  
 Measurement: LU-54185-1

Air performance measured according to ISO 5801 installation category A. For detailed information on the measurement setup, contact ebmpapst. Intake sound level: Sound power level according to ISO 13347 / sound pressure level measured at 1 m distance from fan axis. The values given are valid under the specified measuring conditions and may vary due to conditions of installation. For deviations from the standard configuration, the parameters have to be checked on the installed unit.

## Measured values

	U	n	P <sub>ed</sub>	I	qv	p <sub>fs</sub>	qv	p <sub>fs</sub>
	V	min <sup>-1</sup>	W	A	m <sup>3</sup> /h	Pa	CFM	inH <sub>2</sub> O
1	28	2905	125	5.31	2045	0	1205	0.00
2	28	2785	128	5.51	1840	46	1080	0.18
3	28	2660	131	5.76	1575	91	925	0.37
4	28	2580	134	5.93	1100	136	645	0.55
5	24	2750	105	5.00	1920	0	1130	0.00
6	24	2615	106	5.11	1725	40	1015	0.16
7	24	2510	108	5.29	1475	80	870	0.32
8	24	2420	110	5.47	1035	120	610	0.48
9	16	2180	53	3.74	1520	0	895	0.00
10	16	2120	56	3.91	1370	25	805	0.10
11	16	2050	59	4.12	1195	52	700	0.21
12	16	1995	61	4.29	845	80	500	0.32

U = Power supply · n = Speed (rpm) · P<sub>ed</sub> = Power consumption · I = Current draw · qv = Air flow · p<sub>fs</sub> = Pressure increase

