

EC axial fan

sickle-shaped blades (S series)

ESM fan housing

W1G250-EB17-01 ebmpapst Datasheet

sales@fansco.com

www.fansco.com

Limited partnership · Headquarters Mulfingen

Amtsgericht (court of registration) Stuttgart · HRA 590344

General partner Elektrobau Mulfingen GmbH · Headquarters Mulfingen

Amtsgericht (court of registration) Stuttgart · HRB 590142

Nominal data

Type	W1G250-EB17-01		
Motor	M1G055-BI		
Phase		1~	1~
Nominal voltage	VAC	230	230
Frequency	Hz	50/60	50/60
Method of obtaining data		ml	ml
Speed (rpm)	min ⁻¹	1700	1200
Power consumption	W	35	
Current draw	A	0.28	
Max. back pressure	Pa	50	
Max. back pressure	in. wg	0.2	
Min. ambient temperature	°C	-30	-30
Max. ambient temperature	°C	50	50

ml = Max. load · me = Max. efficiency · fa = Free air · cs = Customer specification · ce = Customer equipment
Subject to change



Technical description

Weight	1 kg
Size	250 mm
Motor size	55
Impeller material	PA plastic
Fan housing material	PP plastic
Number of blades	5
Airflow direction	V
Direction of rotation	Counterclockwise, viewed toward rotor
Degree of protection	IP55
Insulation class	"B"
Moisture (F) / Environmental (H) protection class	H1+
Max. permitted ambient temp. for motor (transport/storage)	+ 80 °C
Min. permitted ambient temp. for motor (transport/storage)	- 40 °C
Installation position	Any
Condensation drainage holes	None
Mode	S1
Motor bearing	Ball bearing
Technical features	<ul style="list-style-type: none"> - Speed setting input (230 V) - ESM+ expandable with plug-in module - Soft start - Thermal overload protection for motor
Speed levels	2
EMC immunity to interference	According to EN 61000-6-2 (industrial environment)
EMC circuit feedback	According to EN 61000-3-2/3
EMC interference emission	According to EN 61000-6-3 (household environment)
Motor protection	Thermal overload protector (TOP) internally connected
With cable	Lateral
Protection class	II
Conformity with standards	EN 60335-1; EN 60335-2-24; EN 60335-2-80; EN 60335-2-89; CE
Approval	VDE; CSA C22.2 No. 77 + CAN/CSA-E60730-1; EAC; UL 1004-3

EC axial fan

sickle-shaped blades (S series)

ESM fan housing

Product drawing

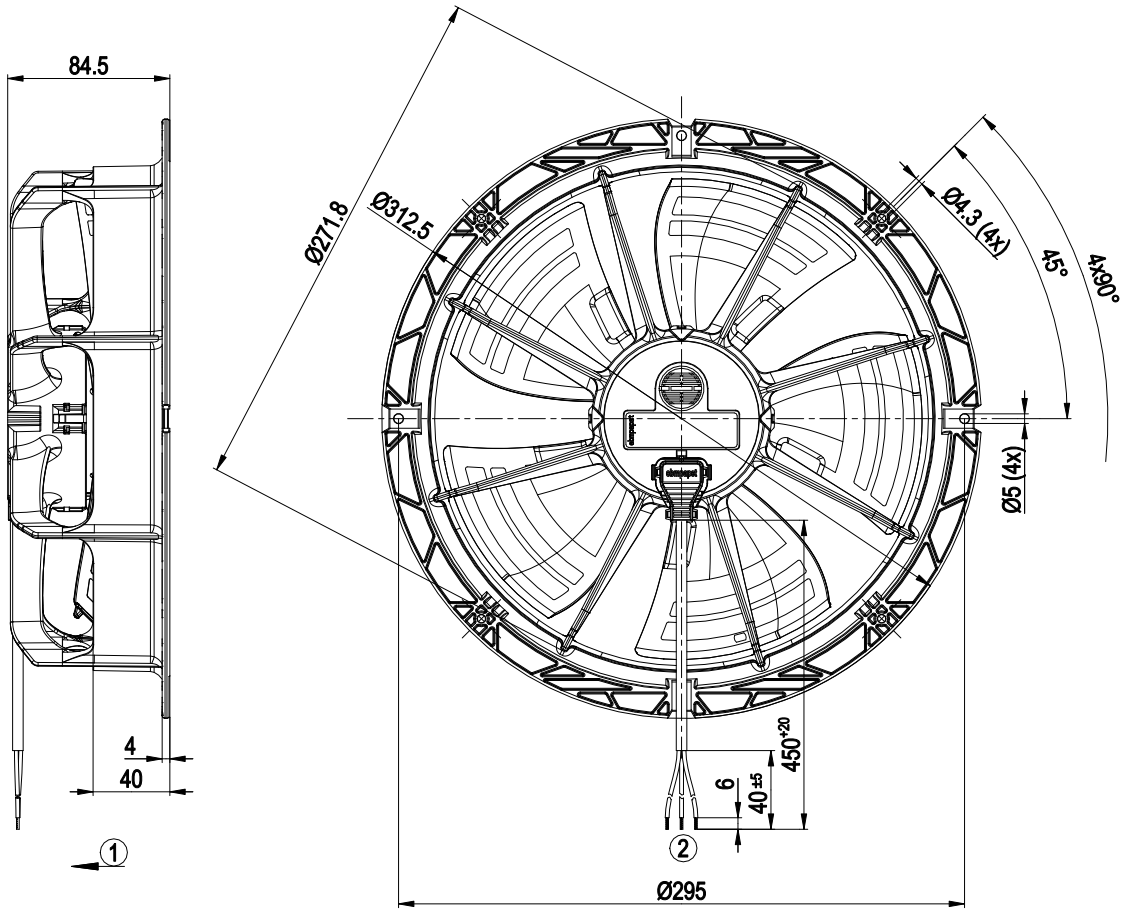

- 1 Airflow direction "V"
- 2 Cable PVC AWG20, 3x crimped splices

Connection diagram

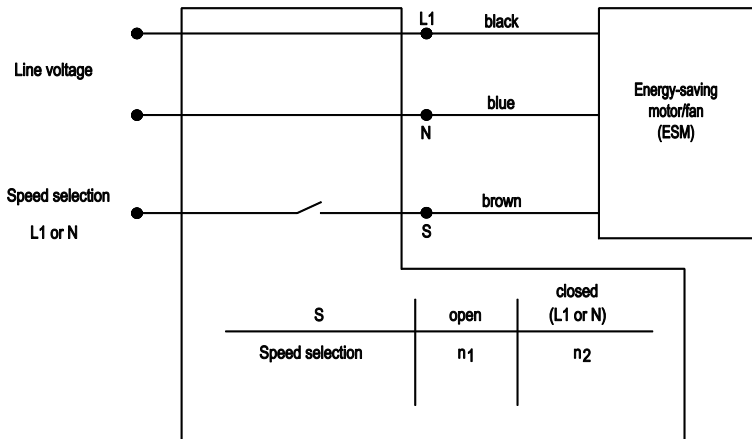

EC axial fan

sickle-shaped blades (S series)

ESM fan housing

Curves: Air performance 50 Hz

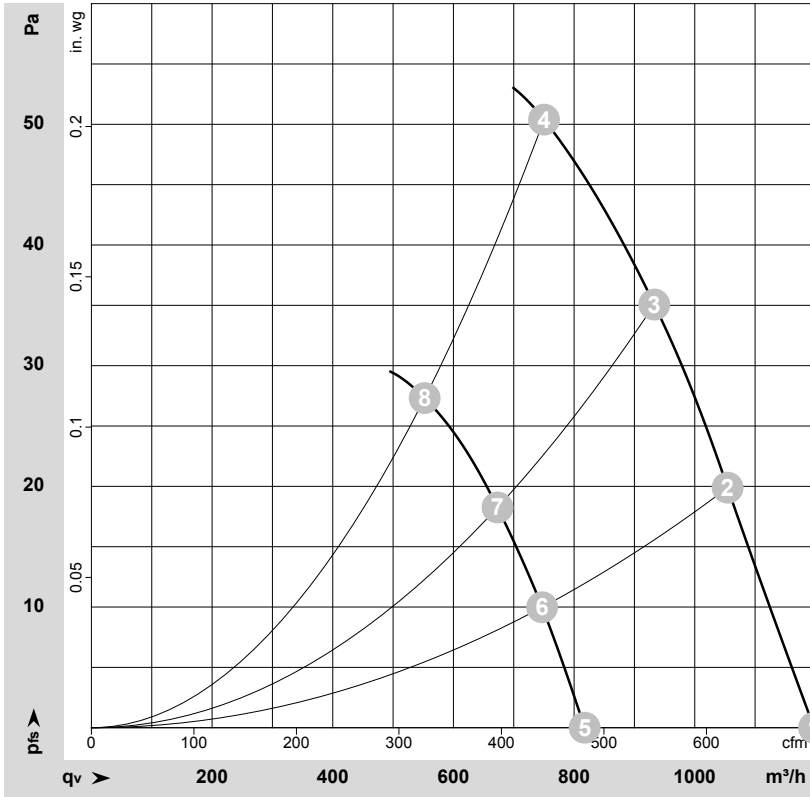

$\rho = 1.15 \text{ kg/m}^3 \pm 2 \%$

Measurement: LU-185362-1
Measurement: LU-185408-1

Air performance measured according to ISO 5801 installation category A. For detailed information on the measurement setup, contact ebm-papst. Intake sound level: Sound power level according to ISO 13347 / sound pressure level measured at 1 m distance from fan axis. The values given are valid under the specified measuring conditions and may vary due to conditions of installation. For deviations from the standard configuration, the parameters have to be checked on the installed unit.

Measured values

	Stage	Wired	U	f	n	P _{ed}	I	LpA _{in}	LwA _{in}	q _v	p _{fs}	q _v	p _{fs}
			V	Hz	min ⁻¹	W	A	dB(A)	dB(A)	m ³ /h	Pa	cfm	in. wg
1	1	1~	230	50	1700	29	0.23	56	64	1200	0	705	0.00
2	1	1~	230	50	1670	31	0.25	55	63	1055	20	620	0.08
3	1	1~	230	50	1650	33	0.26	54	62	935	35	550	0.14
4	1	1~	230	50	1600	35	0.28	54	63	750	50	440	0.20
5	2	1~	230	50	1200	13	0.12	47	55	815	0	480	0.00
6	2	1~	230	50	1200	14	0.13	45	53	745	10	440	0.04
7	2	1~	230	50	1200	16	0.15	44	52	675	18	395	0.07
8	2	1~	230	50	1200	17	0.16	47	56	550	27	325	0.11

Wired = Wiring · U = Voltage · f = Frequency · n = Speed (rpm) · P_{ed} = Power consumption · I = Current draw · LpA_{in} = Sound pressure level intake side · LwA_{in} = Sound power level intake side
q_v = Air flow · p_{fs} = Pressure increase

