

# EC axial fan - ESM

sickle-shaped blades (S series), single-intake

ESM fan housing with guard grille

W1G250-BB29-15 ebmpapst Datasheet

[sales@fansco.com](mailto:sales@fansco.com)

[www.fansco.com](http://www.fansco.com)

Limited partnership · Headquarters Muldingen

Amtsgericht (court of registration) Stuttgart · HRA 590344

General partner Elektrobau Muldingen GmbH · Headquarters Muldingen

Amtsgericht (court of registration) Stuttgart · HRB 590142

## Nominal data

Type	W1G250-BB29-15	
Motor	M1G055-BI	
Phase		1~
Nominal voltage	VAC	230
Frequency	Hz	50/60
Method of obtaining data		ml
Status		prelim.
Speed (rpm)	min <sup>-1</sup>	1150
Power consumption	W	11
Current draw	A	0.1
Max. back pressure	Pa	19
Max. back pressure	in. wg	0.08
Min. ambient temperature	°C	-30
Max. ambient temperature	°C	50

ml = Max. load · me = Max. efficiency · fa = Free air · cs = Customer specification · ce = Customer equipment  
Subject to change



# EC axial fan - ESM

sickle-shaped blades (S series), single-intake

ESM fan housing with guard grille

## Technical description

<b>Weight</b>	1.5 kg
<b>Size</b>	250 mm
<b>Motor size</b>	55
<b>Blade material</b>	PA plastic
<b>Fan housing material</b>	PP plastic
<b>Number of blades</b>	5
<b>Airflow direction</b>	V
<b>Direction of rotation</b>	Counterclockwise, viewed toward rotor
<b>Degree of protection</b>	IP55; only with suitable plug, to be installed by customer
<b>Insulation class</b>	"B"
<b>Moisture (F) / Environmental (H) protection class</b>	H1+
<b>Max. permitted ambient temp. for motor (transport/storage)</b>	+ 80 °C
<b>Min. permitted ambient temp. for motor (transport/storage)</b>	- 40 °C
<b>Installation position</b>	Any
<b>Condensation drainage holes</b>	None
<b>Mode</b>	S1
<b>Motor bearing</b>	Ball bearing
<b>Technical features</b>	<ul style="list-style-type: none"> <li>- Speed setting input (230 V)</li> <li>- Power limiter</li> <li>- Motor current limitation</li> <li>- Soft start</li> <li>- Thermal overload protection for motor</li> </ul>
<b>Electrical hookup</b>	Plug
<b>Motor protection</b>	Thermal overload protector (TOP) internally connected
<b>With cable</b>	Lateral
<b>Protection class</b>	II
<b>Conformity with standards</b>	EN 60034-1; EN 60204-1; EN 60335-1; EN 60335-2-24; EN 60335-2-80; EN 60335-2-89; CE
<b>Approval</b>	VDE; EAC



# EC axial fan - ESM

sickle-shaped blades (S series), single-intake

ESM fan housing with guard grille

## Product drawing

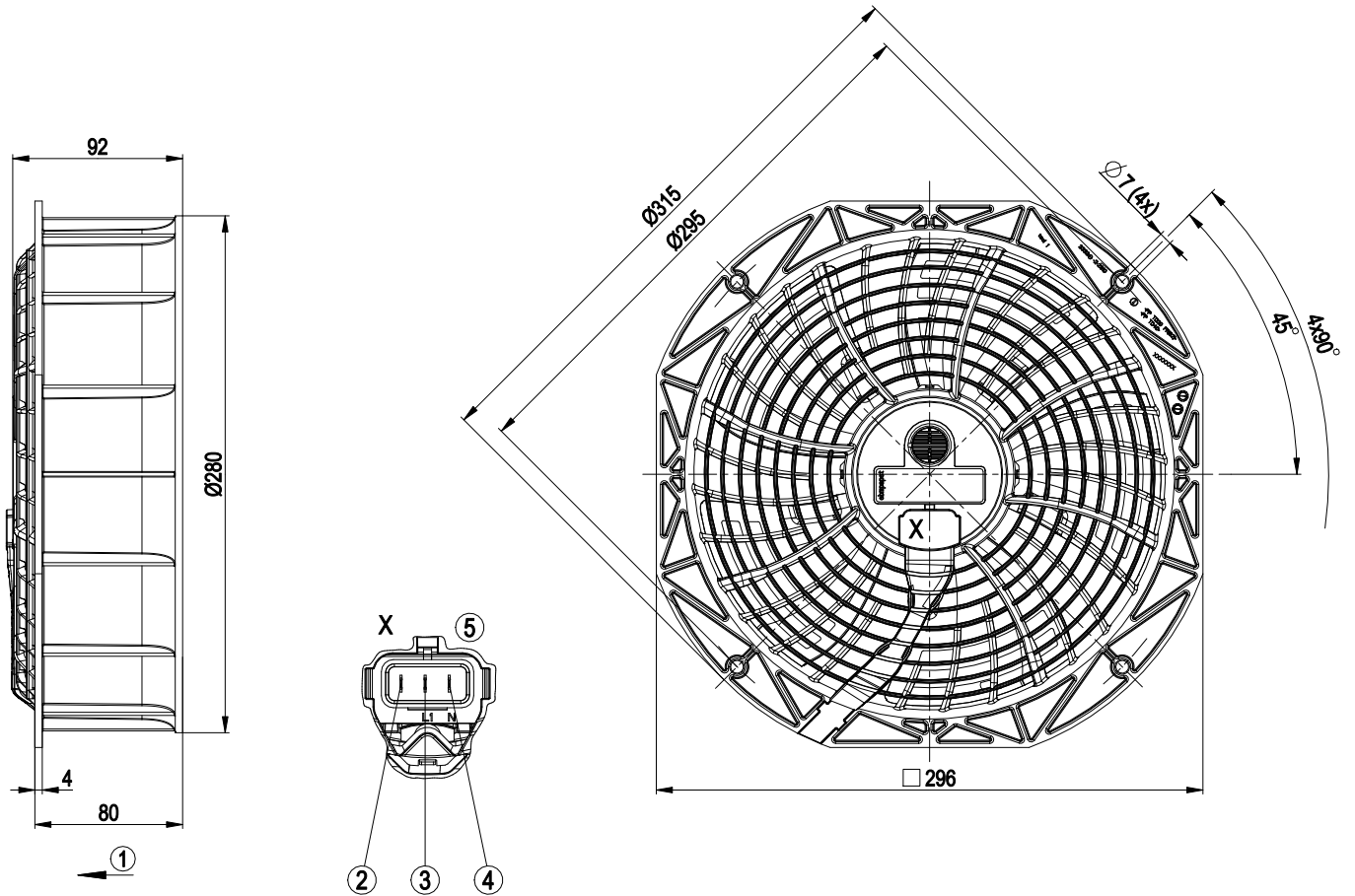

1	Airflow direction "V"
2	Pin S, speed selection (flat plug 2.8 x 0.5)
3	Pin L1, phase (flat plug 2.8 x 0.5)
4	Pin N, neutral conductor (flat plug 2.8 x 0.5)
5	View without cap



# EC axial fan - ESM

sickle-shaped blades (S series), single-intake

ESM fan housing with guard grille

## Connection diagram

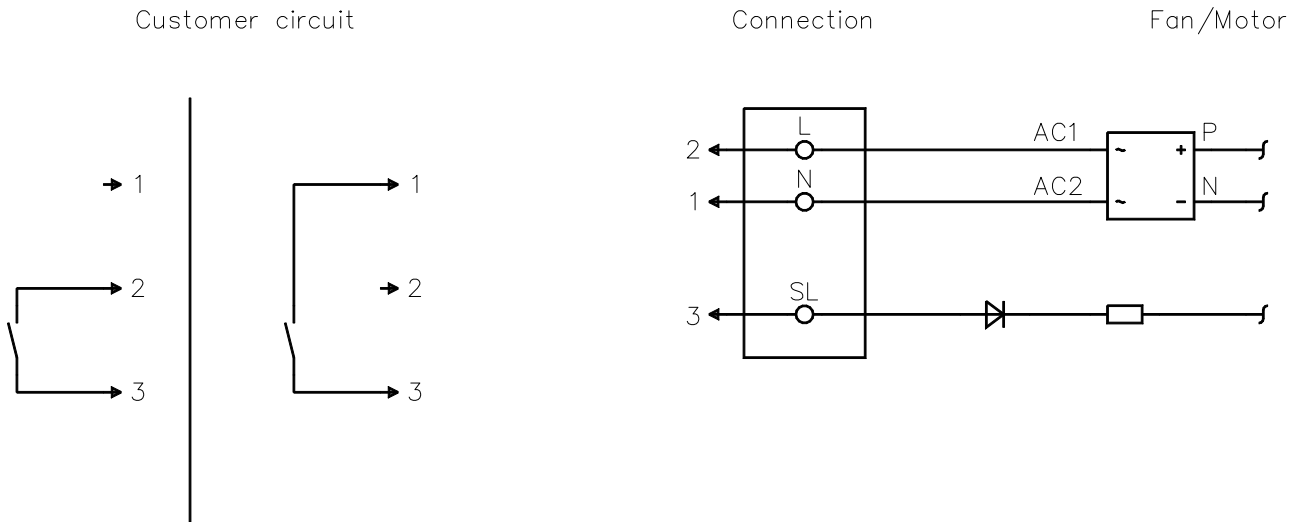

No.	Conn.	Designation	Color	Function/assignment
1	N		blue	Power supply, neutral conductor, see nameplate for voltage range
2	L		black	Power supply, phase, see nameplate for voltage range
3	SL		brown	Speed selection: switch open speed 1, switch closed speed 2



# EC axial fan - ESM

sickle-shaped blades (S series), single-intake

ESM fan housing with guard grille

## Curves: Air performance 50 Hz

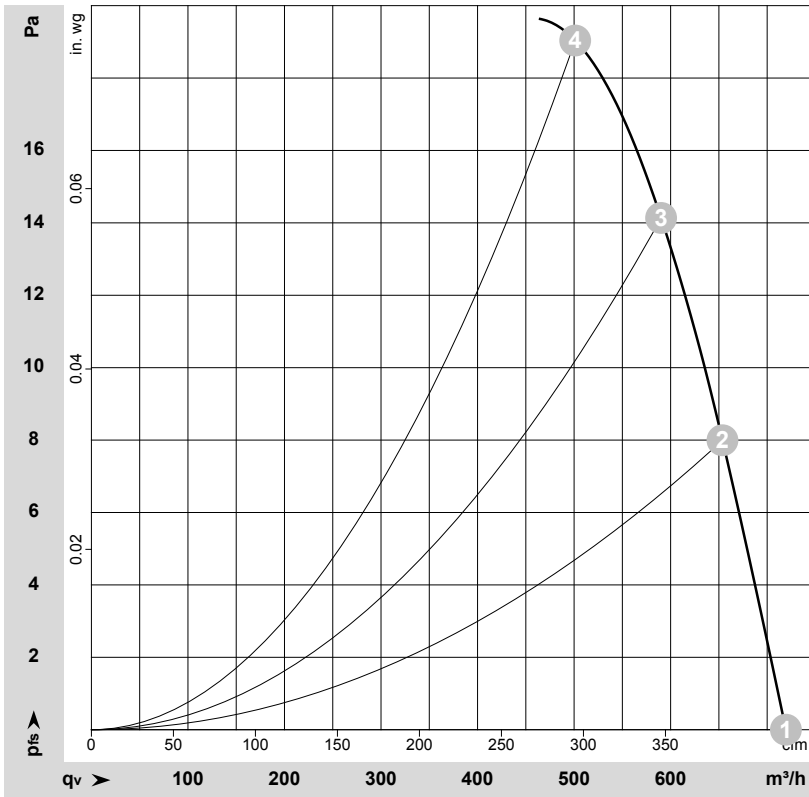

$\rho = 1.15 \text{ kg/m}^3 \pm 2 \%$

Measurement: LU-201126-1

Air performance measured according to ISO 5801 installation category A. For detailed information on the measurement setup, contact ebmpapst. Intake sound level: Sound power level according to ISO 13347 / sound pressure level measured at 1 m distance from fan axis. The values given are valid under the specified measuring conditions and may vary due to conditions of installation. For deviations from the standard configuration, the parameters have to be checked on the installed unit.

## Measured values

	Stage	Wired	U	f	n	P <sub>ed</sub>	I	LpA <sub>in</sub>	LwA <sub>in</sub>	q <sub>v</sub>	p <sub>fs</sub>	q <sub>v</sub>	p <sub>fs</sub>
			V	Hz	min <sup>-1</sup>	W	A	dB(A)	dB(A)	m <sup>3</sup> /h	Pa	cfm	in. wg
1	1	1~	230	50	1150	10.0	0.09	44	51	720	0	425	0.00
2	1	1~	230	50	1150	11	0.10	46	53	655	8	385	0.03
3	1	1~	230	50	1150	11	0.10	47	55	590	14	345	0.06
4	1	1~	230	50	1150	11	0.10	47	55	500	19	295	0.08

Wired = Wiring · U = Voltage · f = Frequency · n = Speed (rpm) · P<sub>ed</sub> = Power consumption · I = Current draw · LpA<sub>in</sub> = Sound pressure level intake side · LwA<sub>in</sub> = Sound power level intake side  
 q<sub>v</sub> = Air flow · p<sub>fs</sub> = Pressure increase

