

W1G200-HH77-56

EC axial compact fan

sickle-shaped blades (S series)



W1G200-HH77-56 ebmpapst Datasheet

sales@fansco.com

www.fansco.com

Limited partnership · Headquarters Muldingen
Amtsgericht (court of registration) Stuttgart · HRA 590344

General partner Elektrobau Muldingen GmbH · Headquarters Muldingen
Amtsgericht (court of registration) Stuttgart · HRB 590142

Nominal data

Type	W1G200-HH77-56	
Motor	M1G074-BF	
Nominal voltage	VDC	24
Nominal voltage range	VDC	16 .. 28
Frequency	Hz	-
Method of obtaining data		fa
Speed (rpm)	min ⁻¹	2950
Power consumption	W	55
Current draw	A	2.6
Max. ambient temperature	°C	60

ml = Max. load · me = Max. efficiency · fa = Free air · cs = Customer specification · ce = Customer equipment
Subject to change



Technical description

Weight	2.22 kg
Size	200 mm
Motor size	74
Rotor surface	Painted black
Blade material	Sheet steel, painted black
Fan housing material	Die-cast aluminum
Number of blades	9
Airflow direction	V
Direction of rotation	Counterclockwise, viewed toward rotor
Degree of protection	IP44; installation- and position-dependent as per EN 60034-5
Insulation class	"B"
Moisture (F) / Environmental (H) protection class	H2
Max. permitted ambient temp. for motor (transport/storage)	+ 70 °C
Min. permitted ambient temp. for motor (transport/storage)	- 40 °C
Installation position	Shaft horizontal or rotor on bottom; rotor on top on request
Condensation drainage holes	On rotor side
Mode	S1
Motor bearing	Ball bearing with low-temperature lubricant
Technical features	<ul style="list-style-type: none"> - Tach output - Motor current limitation - Soft start - Control input 0-10 VDC / PWM
Motor protection	Reverse polarity and locked-rotor protection
Protection class	I (if the protective earth is connected by the customer to the marked PE connection point)
Conformity with standards	EN 60335-1
Approval	UL 1004-1; CSA C22.2 No. 77

Product drawing

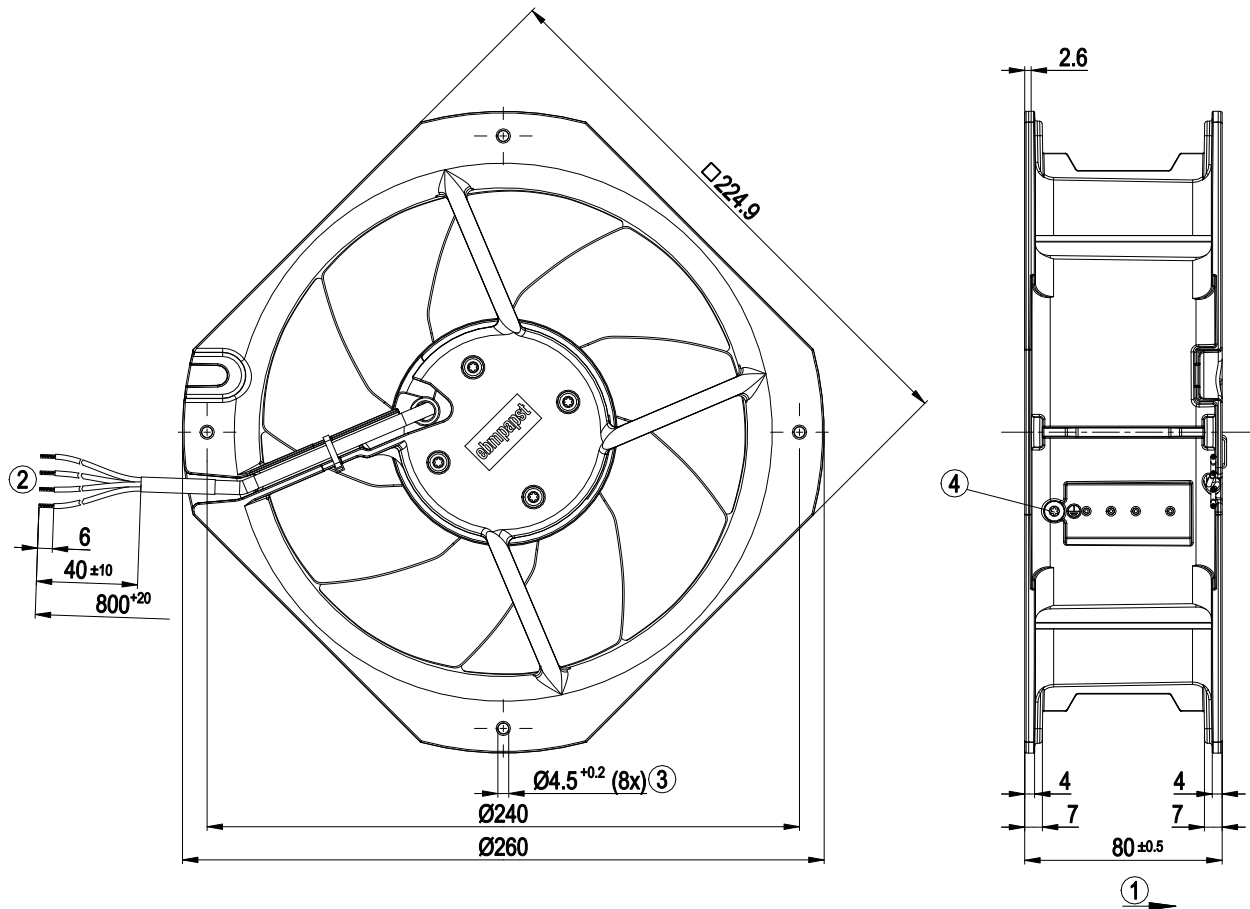

1	Airflow direction "V"
2	Cable silicone 4x 0.5 mm ² , 4x crimped splices
3	For self-tapping M5 screws
4	M4 screw for fastening ground connector

Connection diagram

Customer circuit

Full speed

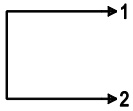

Adjustable speed

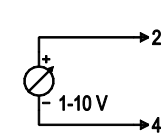

10 V → n = max
1 V → n = min
< 1 V → n = 0
Safe start at Unom -30% from 4 V Ucontr.

Speed adjustable via potentiometer

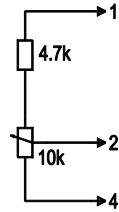

Speed adjustable via PWM 1-10 kHz

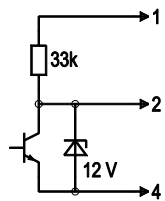

100% PWM → n = max
10% PWM → n = min
< 10% PWM → n = 0
Safe start at Unom -30% from 40% PWM

Set value requirement via temperature controller

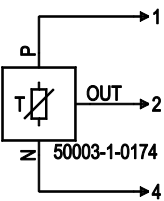

T < 10 °C → n = 0
T > 45 °C → n = max

Connection

Fan / Motor

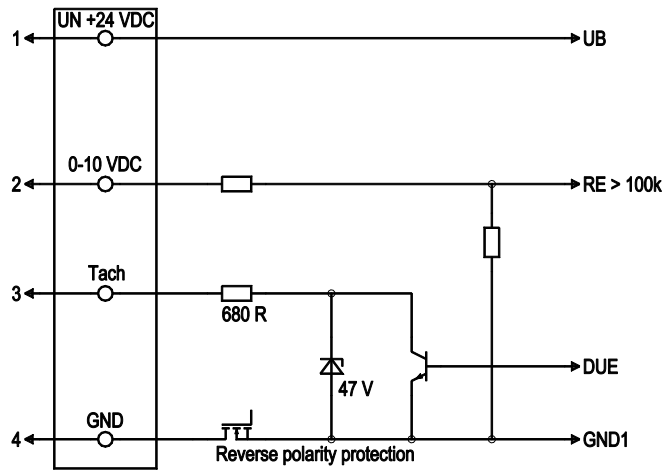

No.	Conn.	Designation	Color	Function/assignment
1	1	Un +24 VDC	red	Power supply 24 VDC, maximum ripple 3.5 %
1	2	0-10 VDC	yellow	Control input Re > 100k
1	3	Tach	white	Tach output, 3 pulses per revolution, Isink max = 10 mA
1	4	GND	blue	Reference ground



Curves: Air performance

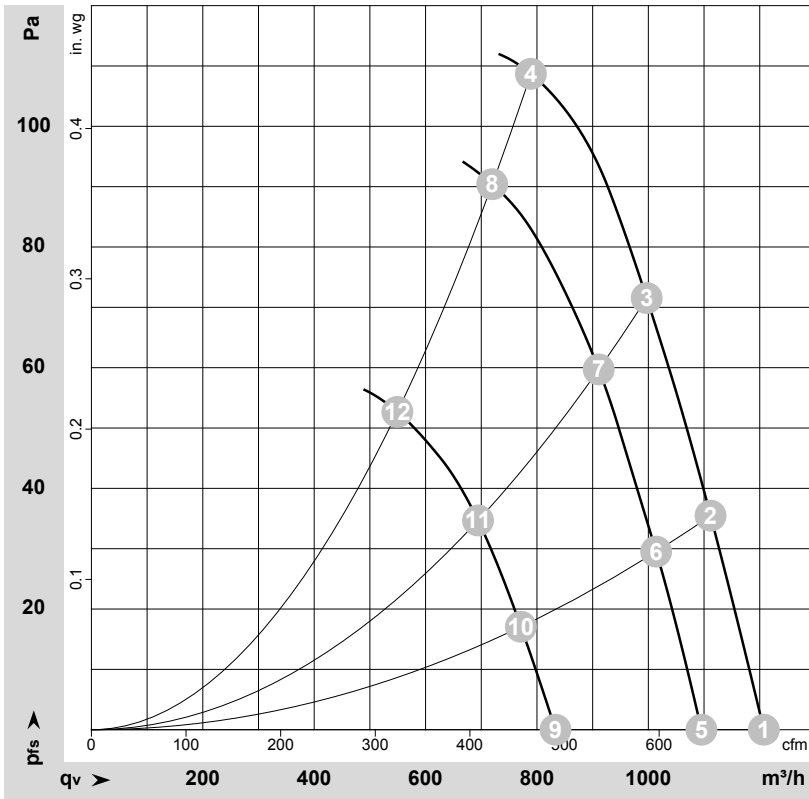

$\rho = 1.15 \text{ kg/m}^3 \pm 2 \%$

Measurement: LU-48037-1
 Measurement: LU-48036-1
 Measurement: LU-48038-1

Air performance measured according to ISO 5801 installation category A. For detailed information on the measurement setup, contact ebmpapst. Intake sound level: Sound power level according to ISO 13347 / sound pressure level measured at 1 m distance from fan axis. The values given are valid under the specified measuring conditions and may vary due to conditions of installation. For deviations from the standard configuration, the parameters have to be checked on the installed unit.

Measured values

	U	n	P _{ed}	I	q _v	p _{fs}	q _v	p _{fs}
	V	min ⁻¹	W	A	m ³ /h	Pa	cfm	in. wg
1	28	3285	73	2.91	1205	0	710	0.00
2	28	3200	76	3.01	1110	37	655	0.15
3	28	3140	78	3.11	995	72	585	0.29
4	28	3060	83	3.27	790	109	465	0.44
5	24	2950	55	2.60	1095	0	645	0.00
6	24	2915	57	2.67	1015	30	595	0.12
7	24	2860	60	2.77	910	60	535	0.24
8	24	2785	63	2.89	720	90	425	0.36
9	16	2285	28	2.08	835	0	490	0.00
10	16	2245	28	2.10	770	18	455	0.07
11	16	2195	29	2.13	695	35	410	0.14
12	16	2145	30	2.18	550	53	325	0.21

U = Voltage · n = Speed (rpm) · P_{ed} = Power consumption · I = Current draw · q_v = Air flow · p_{fs} = Pressure increase

