

W1G200-EF01-20

EC axial fan - ESM

sickle-shaped blades (S series), single-intake

ESM fan housing

W1G200-EF01-20 ebmpapst Datasheet

sales@fansco.com

www.fansco.com

Limited partnership · Headquarters Muldingen

Amtsgericht (court of registration) Stuttgart · HRA 590344

General partner Elektrobau Muldingen GmbH · Headquarters Muldingen

Amtsgericht (court of registration) Stuttgart · HRB 590142

Nominal data

Type	W1G200-EF01-20	
Motor	M1G055-BD	
Nominal voltage	VDC	24
Nominal voltage range	VDC	16 .. 28
Method of obtaining data		fa
Speed	min ⁻¹	2100
Power consumption	W	28
Current draw	A	1.5
Max. back pressure	Pa	55
Min. ambient temperature	°C	-30
Max. ambient temperature	°C	50

ml = Max. load · me = Max. efficiency · fa = Free air · cs = Customer specification · ce = Customer equipment
Subject to change



Technical description

Weight	1 kg
Fan size	200 mm
Blade material	PA plastic
Fan housing material	PP plastic
Number of blades	5
Airflow direction	"V"
Direction of rotation	Counterclockwise, viewed toward rotor
Degree of protection	IP54; only with suitable plug, to be installed by customer
Insulation class	"B"
Moisture (F) / Environmental (H) protection class	F3-1
Max. permitted ambient temp. for motor (transport/storage)	+ 80 °C
Min. permitted ambient temp. for motor (transport/storage)	- 40 °C
Installation position	Any
Condensation drainage holes	None
Mode	S1
Motor storage	Ball bearing
Technical features	<ul style="list-style-type: none"> - Cable break detection with control line - Motor current limitation - Emergency operation - Soft start - Control input via LIN bus - Overvoltage detection - Line undervoltage detection
Motor protection	Thermal overload protector (TOP) internally connected
With cable	Lateral
Protection class	II
Conformity with standards	EN 60335-1; EN 60335-2-24; EN 60335-2-80; EN 60335-2-89

EC axial fan - ESM

sickle-shaped blades (S series), single-intake

ESM fan housing

Connection diagram

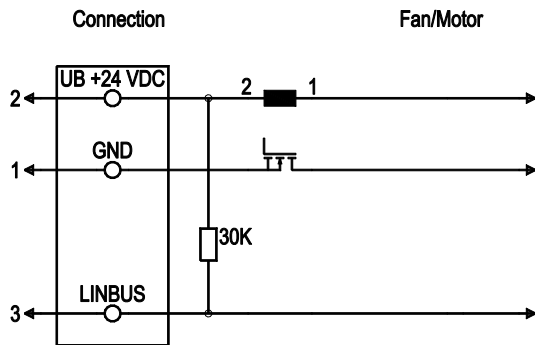

No.	Conn.	Designation	Function/assignment
	1	- UB 0VDC	Power supply GND, reference ground
	2	+ UB 24VDC	Power supply +24 V, see nameplate for voltage range
	3	LIN-Bus 2.1	Bus interface



Curves: Air performance

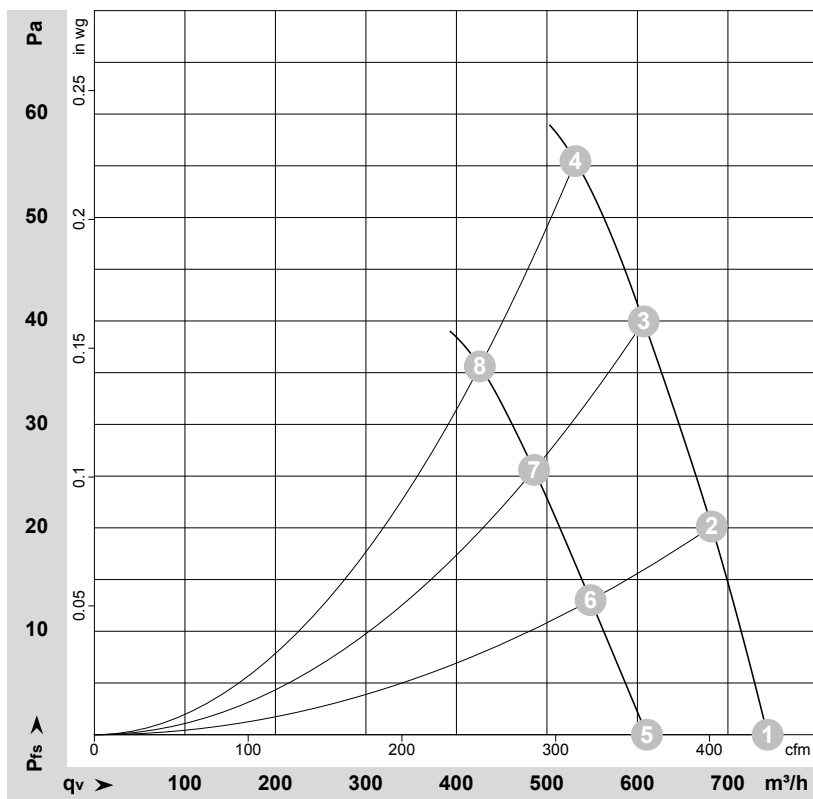

$\rho = 1,15 \text{ kg/m}^3 \pm 2\%$

Measurement: LU-169670
Measurement: LU-169731

Air performance measured according to ISO 5801 installation category A. For detailed information on the measurement setup, contact ebm-papst. Intake sound level: Sound power level according to ISO 13347 / sound pressure level measured at 1 m distance from fan axis. The values given are valid under the specified measuring conditions and may vary due to conditions of installation. For deviations from the standard configuration, the parameters have to be checked on the installed unit.

Measured values

	U	n	P _{ed}	I	qv	p _{fs}
	V	min ⁻¹	W	A	m ³ /h	Pa
1	24	2100	28	1.50	745	0
2	24	2090	30	1.56	680	20
3	24	2060	31	1.62	605	40
4	24	2070	31	1.61	530	55
5	16	1715	14	0.94	610	0
6	16	1680	15	0.99	550	13
7	16	1655	15	1.01	485	26
8	16	1645	15	1.03	425	36

U = Power supply · n = Speed · P_{ed} = Power consumption · I = Current draw · qv = Air flow · p_{fs} = Pressure increase

