

W1G200-EF01-01

# EC axial fan - ESM

sickle-shaped blades (S series)

ESM fan housing



W1G200-EF01-01 ebmpapst Datasheet

[sales@fansco.com](mailto:sales@fansco.com)

[www.fansco.com](http://www.fansco.com)

Limited partnership · Headquarters Muldingen

Amtsgericht (court of registration) Stuttgart · HRA 590344

General partner Elektrobau Muldingen GmbH · Headquarters Muldingen

Amtsgericht (court of registration) Stuttgart · HRB 590142

## Nominal data

Type	W1G200-EF01-01	
Motor	M1G055-BD	
Nominal voltage	VDC	24
Nominal voltage range	VDC	22 .. 26
Method of obtaining data		fa
Speed (rpm)	min <sup>-1</sup>	2130
Power consumption	W	29
Current draw	A	1.5
Max. back pressure	Pa	55
Max. back pressure	in. wg	0.22
Min. ambient temperature	°C	-30
Max. ambient temperature	°C	50

ml = Max. load · me = Max. efficiency · fa = Free air · cs = Customer specification · ce = Customer equipment  
Subject to change



### Technical description

Weight	1 kg
Size	200 mm
Motor size	55
Electronics housing material	PP plastic
Blade material	PA plastic
Fan housing material	PP plastic
Number of blades	5
Airflow direction	V
Direction of rotation	Counterclockwise, viewed toward rotor
Degree of protection	IP55
Insulation class	"B"
Moisture (F) / Environmental (H) protection class	H1+
Max. permitted ambient temp. for motor (transport/storage)	+ 80 °C
Min. permitted ambient temp. for motor (transport/storage)	- 40 °C
Installation position	Any
Condensation drainage holes	None
Mode	S1
Motor bearing	Ball bearing
Technical features	<ul style="list-style-type: none"> <li>- Tach output</li> <li>- Motor current limitation</li> <li>- Soft start</li> <li>- Control input 0-10 VDC / PWM</li> <li>- Thermal overload protection for electronics/motor</li> </ul>
Motor protection	Thermal overload protector (TOP) internally connected
With cable	Lateral
Protection class	II
Conformity with standards	EN 60335-1; EN 60335-2-24; EN 60335-2-80; EN 60335-2-89
Approval	VDE; CSA C22.2 No. 77; EAC; UL 1004-3

# EC axial fan - ESM

sickle-shaped blades (S series)

ESM fan housing

## Product drawing

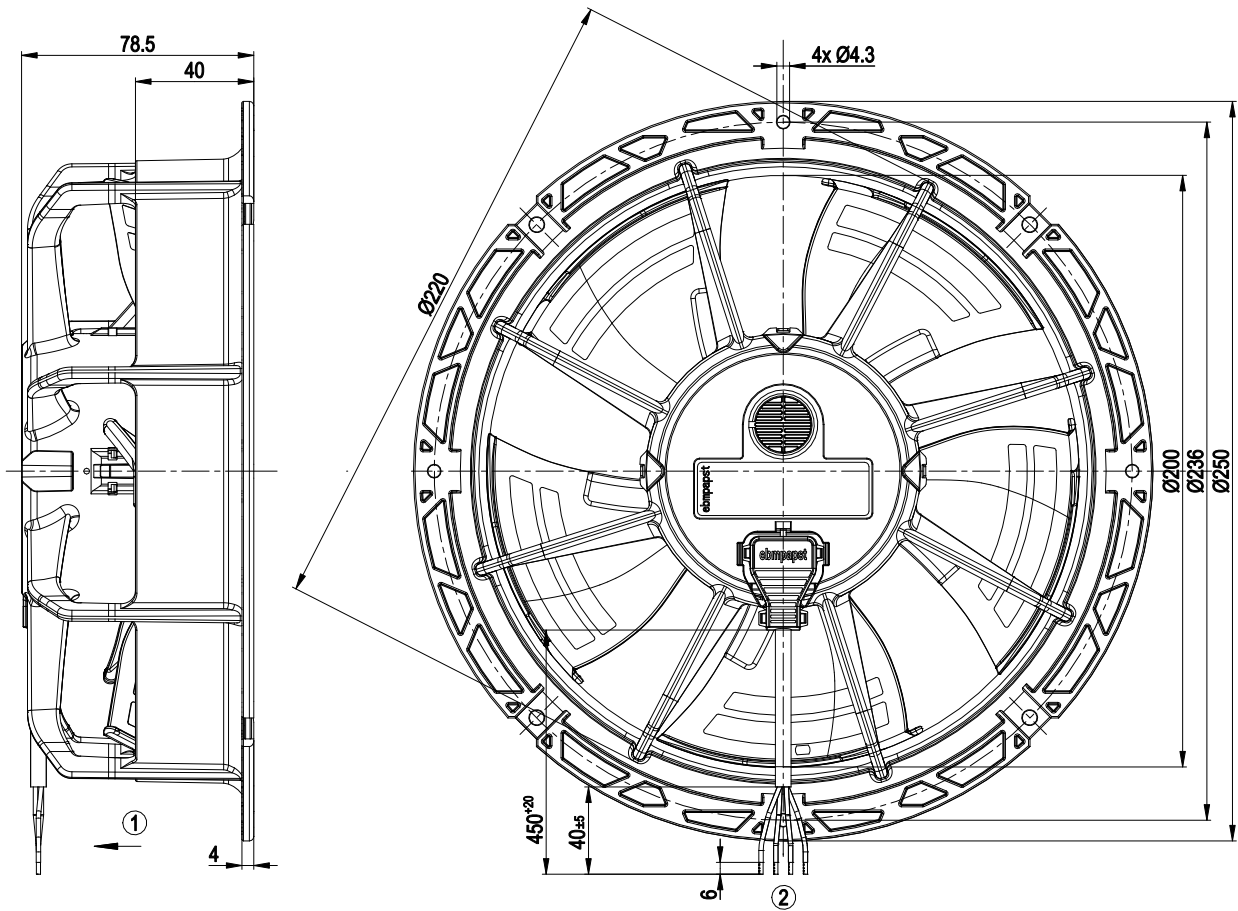

- |   |                                 |
|---|---------------------------------|
| 1 | Direction of air flow "V"       |
| 2 | Cable AWG20, 4x crimped splices |



# EC axial fan - ESM

sickle-shaped blades (S series)

ESM fan housing

## Connection diagram

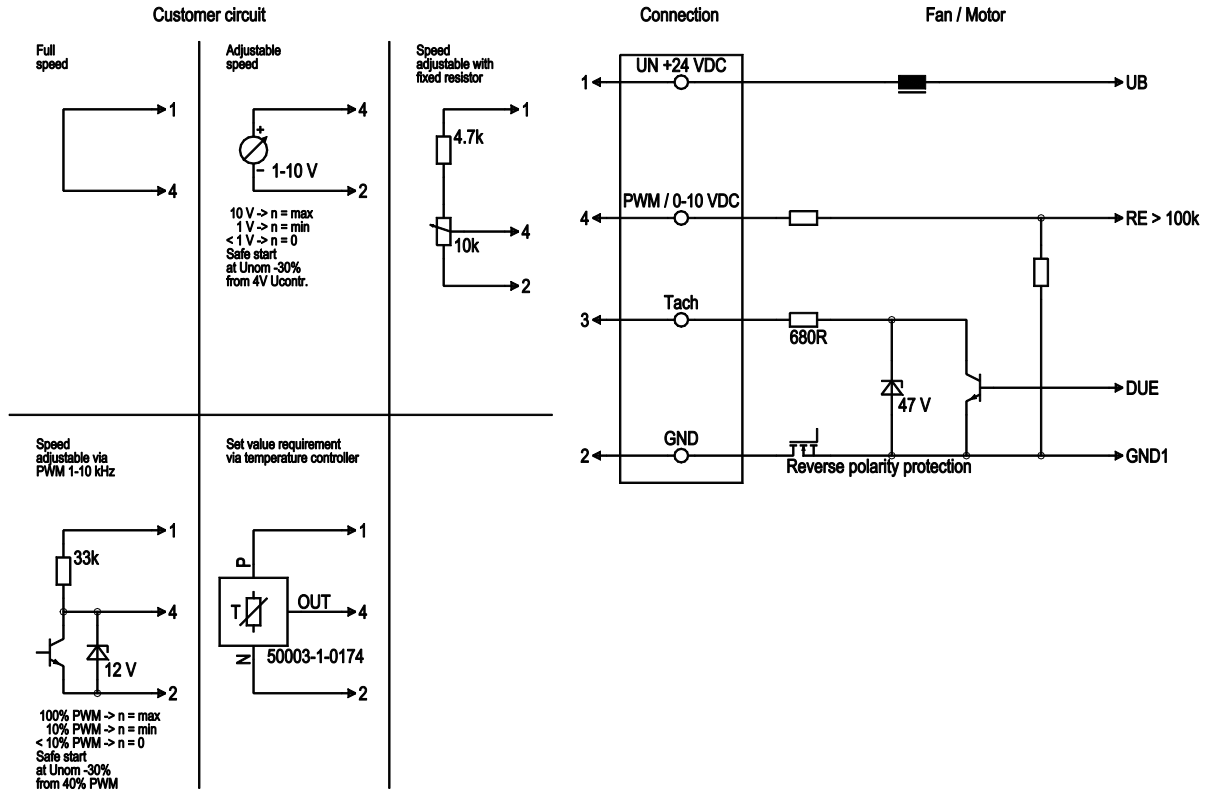

No.	Conn.	Designation	Color	Function/assignment
	1	UN +24 VDC	red	Power supply 24 VDC, maximum ripple 3.5%
	2	GND	blue	Reference ground
	3	Tach	white	Tach output, 1 pulse per revolution, Isink max = 10 mA, open collector
	4	PWM / 0-10 VDC	yellow	Control input PWM or 0-10 V, RE > 100k



# EC axial fan - ESM

sickle-shaped blades (S series)

ESM fan housing

## Curves: Air performance

$$\rho = 1.15 \text{ kg/m}^3 \pm 2 \%$$

Measurement: LU-140491-1  
Measurement: LU-140490-1

Air performance measured according to ISO 5801 installation category A. For detailed information on the measurement setup, contact ebm-papst. Intake sound level: Sound power level according to ISO 13347 / sound pressure level measured at 1 m distance from fan axis. The values given are valid under the specified measuring conditions and may vary due to conditions of installation. For deviations from the standard configuration, the parameters have to be checked on the installed unit.

## Measured values

	U	n	P <sub>ed</sub>	I	LpA <sub>in</sub>	LwA <sub>in</sub>	q <sub>v</sub>	p <sub>fs</sub>	q <sub>v</sub>	p <sub>fs</sub>
	V	min <sup>-1</sup>	W	A	dB(A)	dB(A)	m <sup>3</sup> /h	Pa	cfm	in. wg
1	28	2310	38	1.80			830	0	490	0.00
2	28	2255	40	1.88			750	24	440	0.10
3	28	2220	42	1.97			650	48	385	0.19
4	28	2245	41	1.91			560	65	330	0.26
5	24	2130	29	1.50	55	63	755	0	445	0.00
6	24	2085	30	1.56	54	61	675	20	400	0.08
7	24	2050	31	1.61	52	60	590	40	350	0.16
8	24	2060	31	1.60	50	58	515	55	305	0.22

U = Voltage · n = Speed (rpm) · P<sub>ed</sub> = Power consumption · I = Current draw · LpA<sub>in</sub> = Sound pressure level intake side · LwA<sub>in</sub> = Sound power level intake side · q<sub>v</sub> = Air flow  
p<sub>fs</sub> = Pressure increase

