

W1G200-EC91-44

## EC axial fan - ESM

sickle-shaped blades (S series)

ESM fan housing



W1G200-EC91-44 ebmpapst Datasheet

[sales@fansco.com](mailto:sales@fansco.com)

[www.fansco.com](http://www.fansco.com)

### Nominal data

|                          |                   |       |       |
|--------------------------|-------------------|-------|-------|
| Type                     | W1G200-EC91-44    |       |       |
| Motor                    | M1G055-BD         |       |       |
| Phase                    |                   | 1~    | 1~    |
| Nominal voltage          | VAC               | 230   | 230   |
| Frequency                | Hz                | 50/60 | 50/60 |
| Method of obtaining data |                   | ml    |       |
| Speed (rpm)              | min <sup>-1</sup> | 2100  | 1500  |
| Power consumption        | W                 | 31    |       |
| Current draw             | A                 | 0.24  |       |
| Max. back pressure       | Pa                | 55    |       |
| Max. back pressure       | in. wg            | 0.22  |       |
| Min. ambient temperature | °C                | -30   | -30   |
| Max. ambient temperature | °C                | 50    | 50    |

ml = Max. load · me = Max. efficiency · fa = Free air · cs = Customer specification · ce = Customer equipment  
Subject to change



# EC axial fan - ESM

sickle-shaped blades (S series)

ESM fan housing

## Technical description

|   |  |
|---|--|
| <b>Weight</b>   | 0.86 kg  |
| <b>Size</b>   | 200 mm   |
| <b>Motor size</b>   | 55   |
| <b>Blade material</b>   | PA plastic   |
| <b>Fan housing material</b>   | PP plastic   |
| <b>Number of blades</b>   | 5  |
| <b>Airflow direction</b>  | V  |
| <b>Direction of rotation</b>  | Counterclockwise, viewed toward rotor  |
| <b>Degree of protection</b>   | IP55; only with suitable plug, to be installed by customer   |
| <b>Insulation class</b>   | "B"  |
| <b>Moisture (F) / Environmental (H) protection class</b>                          | H1+  |
| <b>Max. permitted ambient temp. for motor (transport/storage)</b>                 | +80 °C   |
| <b>Min. permitted ambient temp. for motor (transport/storage)</b>                 | -40 °C   |
| <b>Installation position</b>  | Any  |
| <b>Condensation drainage holes</b>  | None   |
| <b>Mode</b>   | S1   |
| <b>Motor bearing</b>  | Ball bearing   |
| <b>Technical features</b>   | <ul style="list-style-type: none"> <li>- Speed selection max./min.</li> <li>- ESM+ expandable with plug-in module</li> <li>- Soft start</li> <li>- Thermal overload protection for motor</li> </ul>  |
| <b>Speed levels</b>   | 2  |
| <b>EMC immunity to interference</b>   | According to EN 61000-6-2 (industrial environment)   |
| <b>EMC circuit feedback</b>   | According to EN 61000-3-2/3  |
| <b>EMC interference emission</b>  | According to EN 61000-6-3 (household environment)  |
| <b>Touch current according to IEC 60990 (measuring circuit Fig. 4, TN system)</b> | <= 0.25 mA   |
| <b>Electrical hookup</b>  | Plug   |
| <b>Motor protection</b>   | Thermal overload protector (TOP) internally connected  |
| <b>Protection class assignment</b>  | <p>II; This component for installation may have several local protection classes. This information relates to this component's basic design.</p> <p>The final protection class is based on the component's intended installation and connection.</p> |
| <b>Conformity with standards</b>  | EN 60034-1; EN 60204-1; EN 60335-1; EN 60335-2-24; EN 60335-2-80; EN 60335-2-89; CE; UKCA  |
| <b>Approval</b>   | CSA C22.2 No. 77; CCC; VDE; UL 1004-3; EAC   |



# EC axial fan - ESM

sickle-shaped blades (S series)

ESM fan housing

## Product drawing

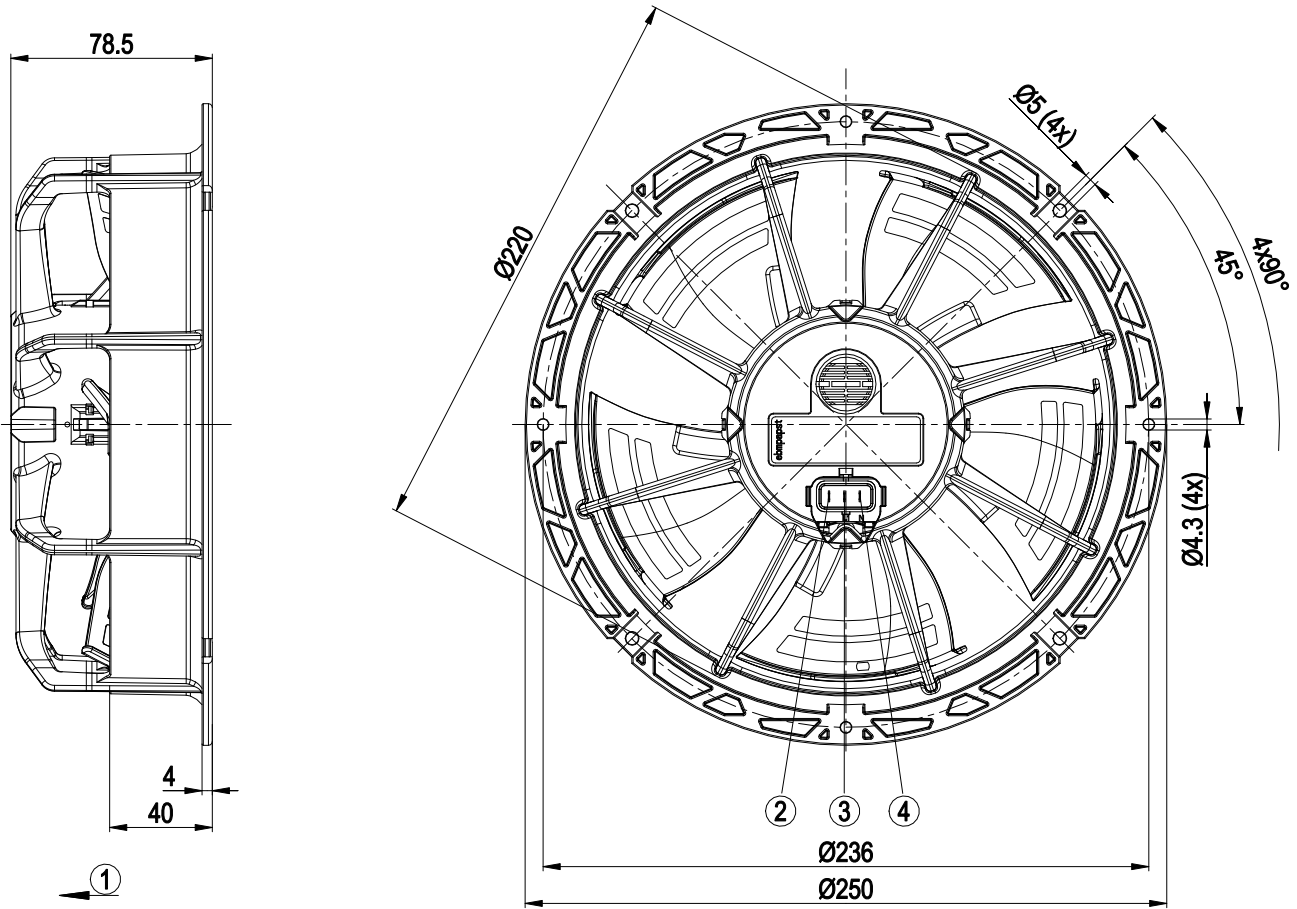

|   |  |
|---|--|
| 1 | Direction of air flow "V"                      |
| 2 | Pin S, speed selection (flat plug 2.8 x 0.5)   |
| 3 | Pin L1, phase (flat plug 2.8 x 0.5)            |
| 4 | Pin N, neutral conductor (flat plug 2.8 x 0.5) |



# EC axial fan - ESM

sickle-shaped blades (S series)

ESM fan housing

## Connection diagram

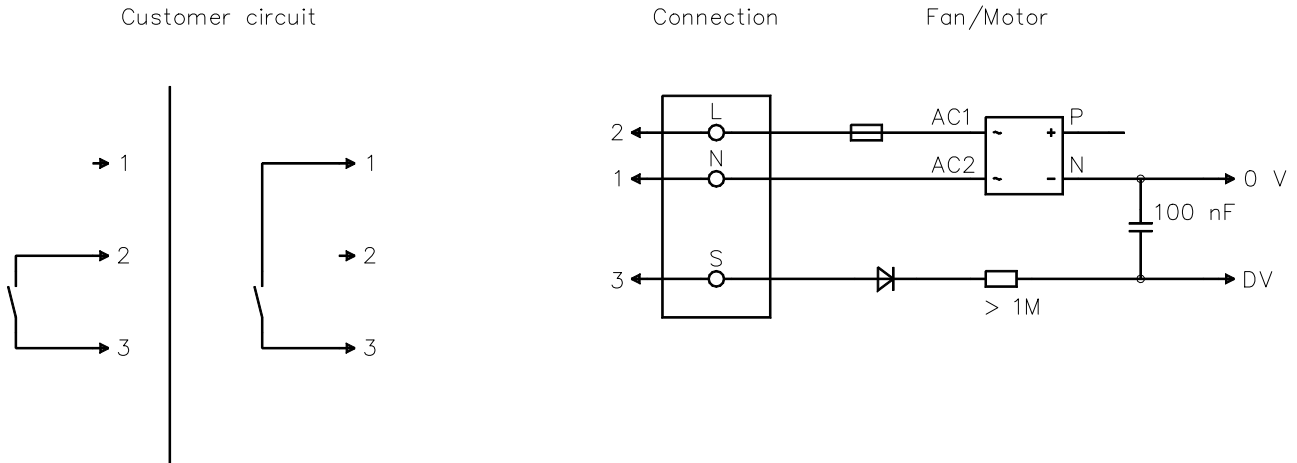

| No. | Conn. | Designation | Color | Function/assignment   |
|-----|-------|-------------|-------|---|
| 1   | N     |             | blue  | Neutral conductor   |
| 2   | L     |             | black | Power supply 230 VAC, 50-60 Hz, see nameplate for voltage range           |
| 3   | S     |             | brown | Speed selection: switch open speed 1 (fast), switch closed speed 2 (slow) |



## Curves: Air performance 50 Hz

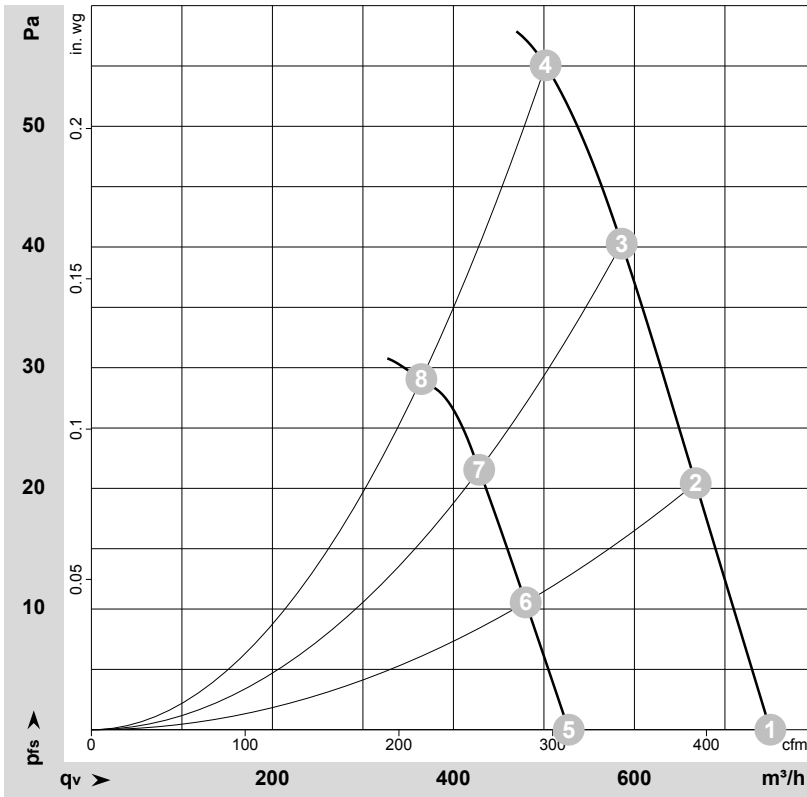

$\rho = 1.15 \text{ kg/m}^3 \pm 2 \%$

Measurement: LU-113351-1  
Measurement: LU-113352-1

Air performance measured according to ISO 5801 installation category A. For detailed information on the measurement setup, contact ebm-papst. Intake sound level: Sound power level according to ISO 13347 / sound pressure level measured at 1 m distance from fan axis. The values given are valid under the specified measuring conditions and may vary due to conditions of installation. For deviations from the standard configuration, the parameters have to be checked on the installed unit.

## Measured values

|   | U   | f  | n                 | P <sub>ed</sub> | I    | LpA <sub>in</sub> | LwA <sub>in</sub> | q <sub>v</sub>    | P <sub>fs</sub> | q <sub>v</sub> | P <sub>fs</sub> |
|---|-----|----|-------------------|-----------------|------|-------------------|-------------------|-------------------|-----------------|----------------|-----------------|
|   | V   | Hz | min <sup>-1</sup> | W               | A    | dB(A)             | dB(A)             | m <sup>3</sup> /h | Pa              | cfm            | in. wg          |
| 1 | 230 | 50 | 2100              | 28              | 0.22 | 55                | 62                | 750               | 0               | 440            | 0.00            |
| 2 | 230 | 50 | 2100              | 30              | 0.23 | 54                | 61                | 670               | 20              | 395            | 0.08            |
| 3 | 230 | 50 | 2100              | 31              | 0.24 | 53                | 60                | 585               | 40              | 345            | 0.16            |
| 4 | 230 | 50 | 2100              | 31              | 0.24 | 56                | 64                | 500               | 55              | 295            | 0.22            |
| 5 | 230 | 50 | 1500              | 14              | 0.11 | 46                | 54                | 525               | 0               | 310            | 0.00            |
| 6 | 230 | 50 | 1500              | 15              | 0.12 | 46                | 54                | 480               | 11              | 285            | 0.04            |
| 7 | 230 | 50 | 1500              | 15              | 0.12 | 45                | 53                | 430               | 22              | 250            | 0.09            |
| 8 | 230 | 50 | 1500              | 15              | 0.12 | 48                | 56                | 365               | 29              | 215            | 0.12            |

U = Voltage · f = Frequency · n = Speed (rpm) · P<sub>ed</sub> = Power consumption · I = Current draw · LpA<sub>in</sub> = Sound pressure level intake side · LwA<sub>in</sub> = Sound power level intake side  
q<sub>v</sub> = Air flow · P<sub>fs</sub> = Pressure increase

