

W1G200-EC91-27

EC axial fan - ESM

sickle-shaped blades (S series)

ESM fan housing



W1G200-EC91-27 ebmpapst Datasheet

sales@fansco.com

www.fansco.com

Nominal data

Type	W1G200-EC91-27		
Motor	M1G055-BD		
Phase		1~	1~
Nominal voltage	VAC	115	115
Frequency	Hz	50/60	50/60
Method of obtaining data		ml	
Speed (rpm)	min ⁻¹	1300	900
Power consumption	W	8.0	
Current draw	A	0.11	
Max. back pressure	Pa	23	
Max. back pressure	in. wg	0.09	
Min. ambient temperature	°C	-30	-30
Max. ambient temperature	°C	50	50

ml = Max. load · me = Max. efficiency · fa = Free air · cs = Customer specification · ce = Customer equipment
Subject to change



Technical description

Weight	0.9 kg
Size	200 mm
Motor size	55
Blade material	PA plastic
Fan housing material	PP plastic
Number of blades	5
Airflow direction	V
Direction of rotation	Counterclockwise, viewed toward rotor
Degree of protection	IP55
Insulation class	"B"
Moisture (F) / Environmental (H) protection class	H1+
Max. permitted ambient temp. for motor (transport/storage)	+ 80 °C
Min. permitted ambient temp. for motor (transport/storage)	- 40 °C
Installation position	Any
Condensation drainage holes	None
Mode	S1
Motor bearing	Ball bearing
Technical features	<ul style="list-style-type: none"> - Speed selection max./min. - ESM+ expandable with plug-in module - Soft start - Thermal overload protection for motor
Speed levels	2
EMC immunity to interference	According to EN 61000-6-2 (industrial environment)
EMC interference emission	According to EN 61000-6-3 (household environment)
Motor protection	Thermal overload protector (TOP) internally connected
With cable	Lateral
Protection class	II
Conformity with standards	EN 60335-1; EN 60335-2-24; EN 60335-2-80; EN 60335-2-89; CE; UKCA
Approval	VDE; CSA C22.2 No. 77; EAC; UL 1004-3

EC axial fan - ESM

sickle-shaped blades (S series)

ESM fan housing

Product drawing

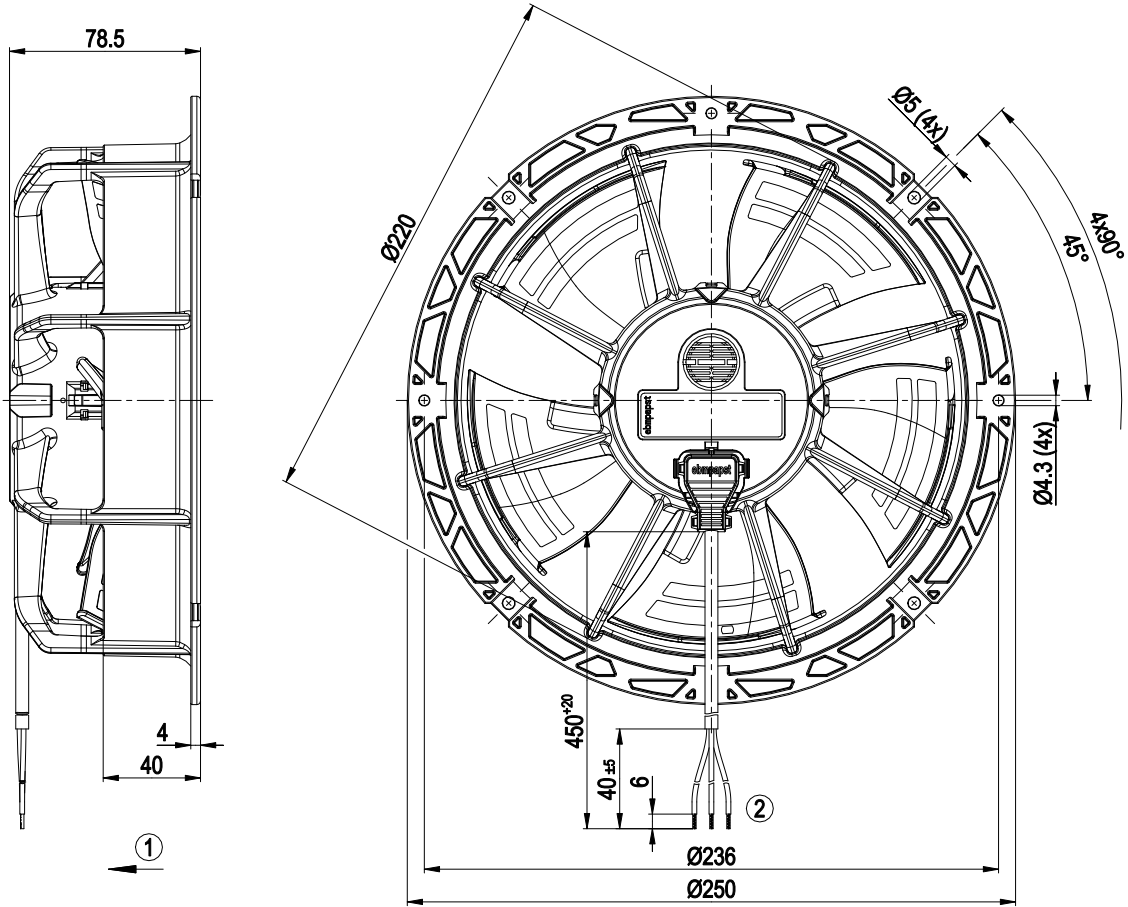

1	Airflow direction "V"
2	Cable PVC AWG20
	3x splice



EC axial fan - ESM

sickle-shaped blades (S series)

ESM fan housing

Connection diagram

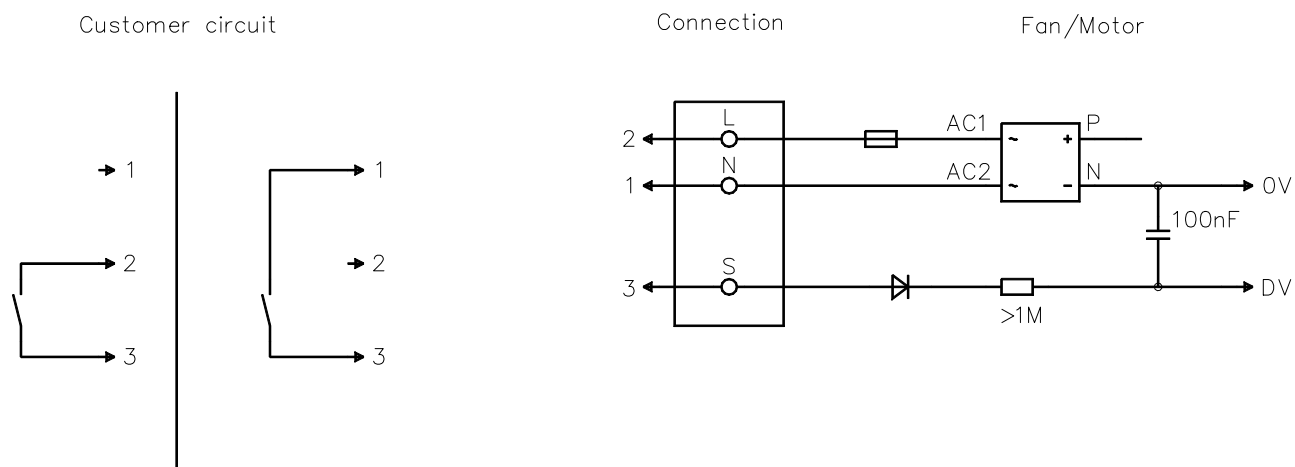

No.	Conn.	Designation	Color	Function/assignment
1	N		blue	Neutral conductor
2	L		black	Power supply 115 VAC, 50-60 Hz, see nameplate for voltage range
3	S		brown	Speed selection: switch open speed 1 (fast), switch closed speed 2 (slow)



EC axial fan - ESM

sickle-shaped blades (S series)

ESM fan housing

Curves: Air performance 50 Hz

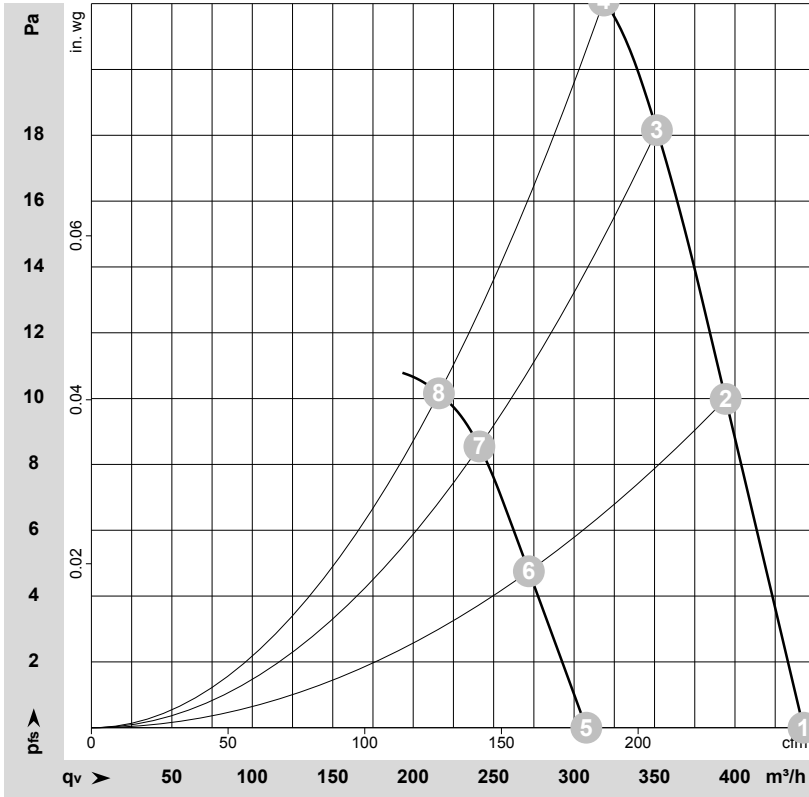

$\rho = 1.15 \text{ kg/m}^3 \pm 2 \%$

Measurement: LU-115139-1
Measurement: LU-115142-1

Air performance measured according to ISO 5801 installation category A. For detailed information on the measurement setup, contact ebm-papst. Intake sound level: Sound power level according to ISO 13347 / sound pressure level measured at 1 m distance from fan axis. The values given are valid under the specified measuring conditions and may vary due to conditions of installation. For deviations from the standard configuration, the parameters have to be checked on the installed unit.

Measured values

	Stage	Wired	U	f	n	P _{ed}	I	LpA _{in}	LwA _{in}	q _v	p _{fs}	q _v	p _{fs}
			V	Hz	min ⁻¹	W	A	dB(A)	dB(A)	m ³ /h	Pa	cfm	in. wg
1	1	1~	115	50	1300	7.0	0.09	42	50	445	0	260	0.00
2	1	1~	115	50	1300	8.0	0.10	41	49	395	10	230	0.04
3	1	1~	115	50	1300	8.0	0.11	40	48	350	18	205	0.07
4	1	1~	115	50	1300	8.0	0.11	42	50	320	23	190	0.09
5	2	1~	115	50	900	3.00	0.05	33	41	310	0	180	0.00
6	2	1~	115	50	900	3.00	0.05	32	41	270	5	160	0.02
7	2	1~	115	50	900	4.0	0.05	32	41	240	9	140	0.04
8	2	1~	115	50	900	4.0	0.05	32	41	215	10	125	0.04

Wired = Wiring · U = Voltage · f = Frequency · n = Speed (rpm) · P_{ed} = Power consumption · I = Current draw · LpA_{in} = Sound pressure level intake side · LwA_{in} = Sound power level intake side
q_v = Air flow · p_{fs} = Pressure increase

