

W1G200-EC91-10 ebmpapst Datasheet FansCo

sales@fansco.com

www.fansco.com

Nominal data

Type	W1G200-EC91-10		
Motor	M1G055-BD		
Phase		1~	1~
Nominal voltage	VAC	230	230
Frequency	Hz	50/60	50/60
Method of obtaining data		ml	
Speed (rpm)	min ⁻¹	2100	1500
Power consumption	W	31	
Current draw	A	0.24	
Max. back pressure	Pa	55	
Max. back pressure	in. wg	0.22	
Min. ambient temperature	°C	-30	-30
Max. ambient temperature	°C	50	50

ml = Max. load · me = Max. efficiency · fa = Free air · cs = Customer specification · ce = Customer equipment
Subject to change



Technical description

Weight	1 kg
Size	200 mm
Motor size	55
Blade material	PA plastic
Fan housing material	PP plastic
Number of blades	5
Airflow direction	V
Direction of rotation	Counterclockwise, viewed toward rotor
Degree of protection	IP55
Insulation class	"B"
Moisture (F) / Environmental (H) protection class	H1+
Max. permitted ambient temp. for motor (transport/storage)	+ 80 °C
Min. permitted ambient temp. for motor (transport/storage)	- 40 °C
Installation position	Any
Condensation drainage holes	None
Mode	S1
Motor bearing	Ball bearing
Technical features	<ul style="list-style-type: none"> - Speed selection max./min. - Soft start - Thermal overload protection for motor
Speed levels	2
EMC immunity to interference	According to EN 61000-6-2 (industrial environment)
EMC circuit feedback	According to EN 61000-3-2/3
EMC interference emission	According to EN 61000-6-3 (household environment)
Motor protection	Thermal overload protector (TOP) internally connected
With cable	Lateral
Protection class	II
Conformity with standards	EN 60335-1; EN 60335-2-24; EN 60335-2-80; EN 60335-2-89; CE
Approval	VDE; CSA C22.2 No. 77; EAC; UL 1004-3

EC axial fan - ESM

sickle-shaped blades (S series)

ESM fan housing

Product drawing

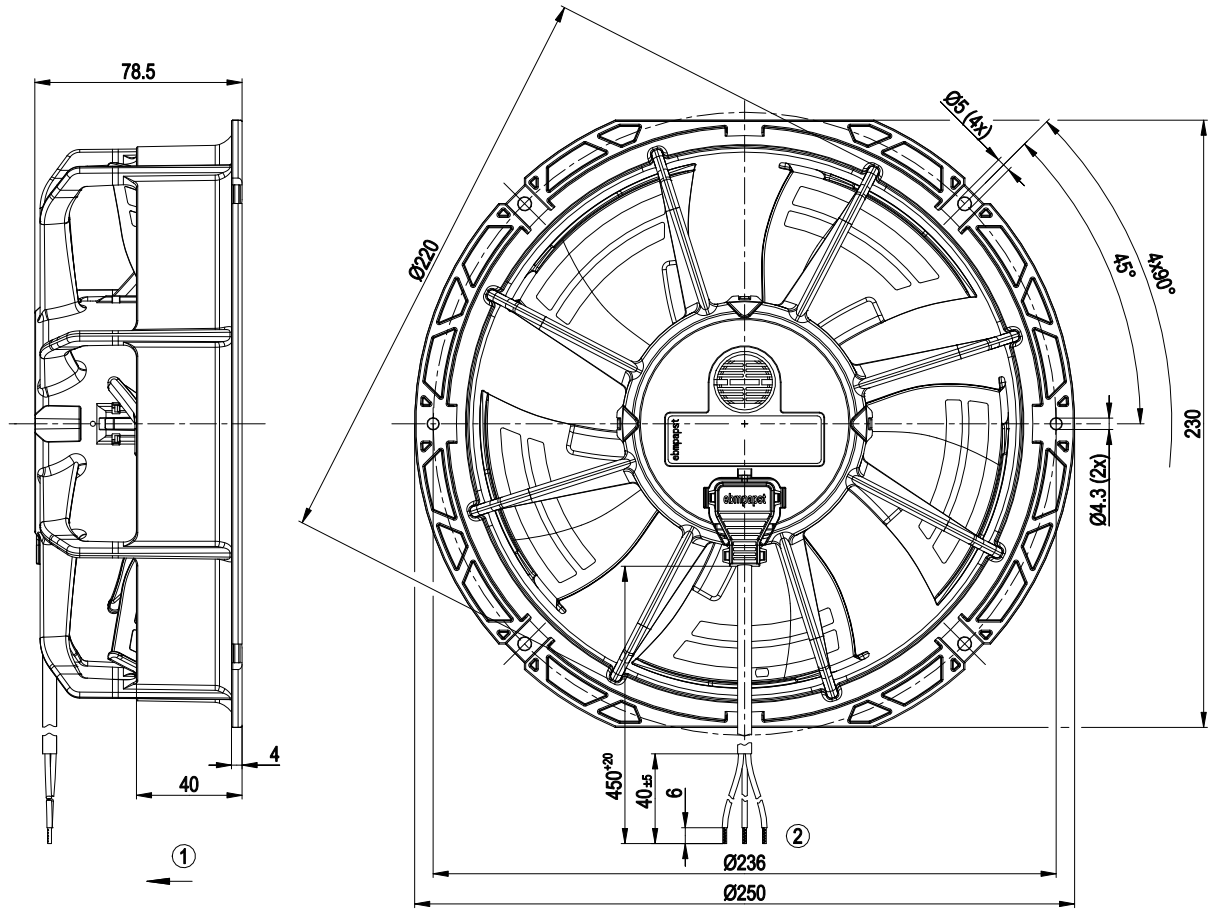

- 1 Direction of air flow "V"
- 2 Cable PVC AWG20, 3x crimped splices

Connection diagram

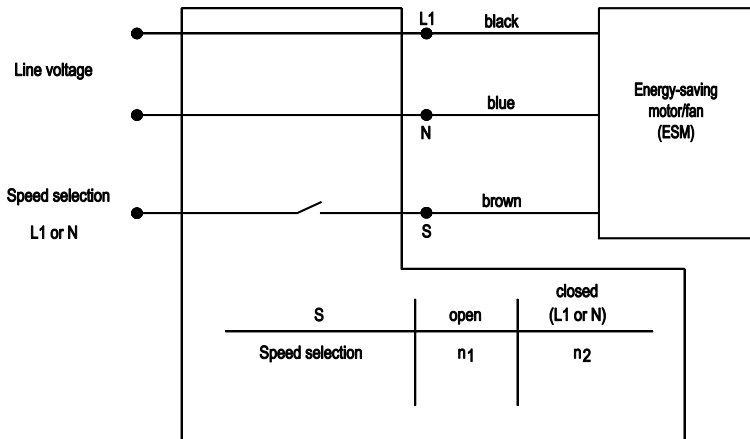

Curves: Air performance 50 Hz

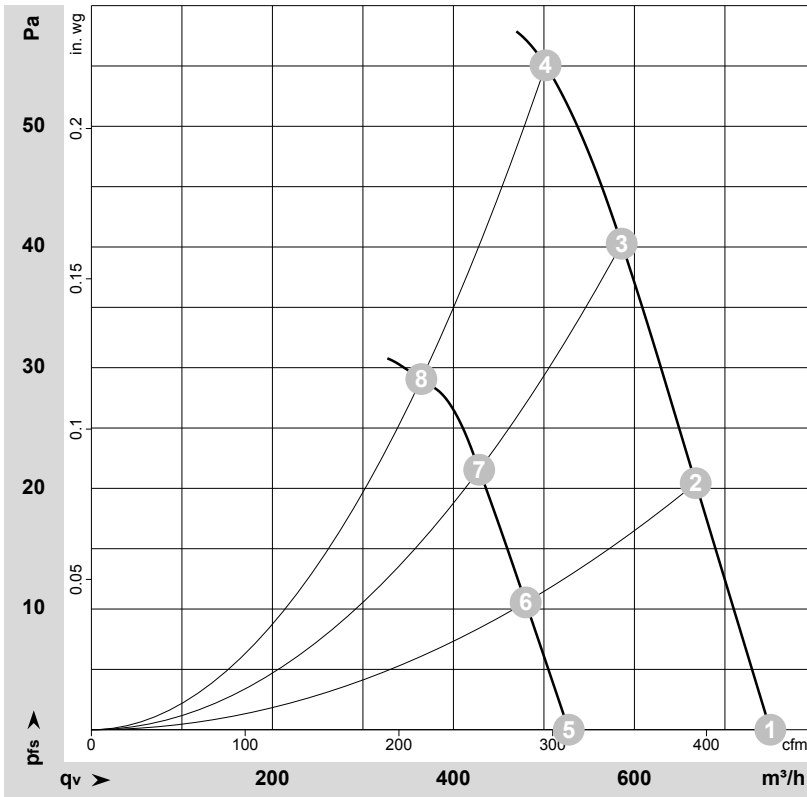

$\rho = 1.15 \text{ kg/m}^3 \pm 2 \%$

Measurement: LU-113351-1
Measurement: LU-113352-1

Air performance measured according to ISO 5801 installation category A. For detailed information on the measurement setup, contact ebm-papst. Intake sound level: Sound power level according to ISO 13347 / sound pressure level measured at 1 m distance from fan axis. The values given are valid under the specified measuring conditions and may vary due to conditions of installation. For deviations from the standard configuration, the parameters have to be checked on the installed unit.

Measured values

	U	f	n	P _{ed}	I	LpA _{in}	LwA _{in}	q _v	P _{fs}	q _v	P _{fs}
	V	Hz	min ⁻¹	W	A	dB(A)	dB(A)	m ³ /h	Pa	cfm	in. wg
1	230	50	2100	28	0.22	55	62	750	0	440	0.00
2	230	50	2100	30	0.23	54	61	670	20	395	0.08
3	230	50	2100	31	0.24	53	60	585	40	345	0.16
4	230	50	2100	31	0.24	56	64	500	55	295	0.22
5	230	50	1500	14	0.11	46	54	525	0	310	0.00
6	230	50	1500	15	0.12	46	54	480	11	285	0.04
7	230	50	1500	15	0.12	45	53	430	22	250	0.09
8	230	50	1500	15	0.12	48	56	365	29	215	0.12

U = Voltage · f = Frequency · n = Speed (rpm) · P_{ed} = Power consumption · I = Current draw · LpA_{in} = Sound pressure level intake side · LwA_{in} = Sound power level intake side
q_v = Air flow · P_{fs} = Pressure increase

