

EC axial fan

sickle-shaped blades (S series), single-intake

ESM fan housing

W1G200-EA91-35 ebmpapst Datasheet

sales@fansco.com

www.fansco.com

Limited partnership · Headquarters Muldingen

Amtsgericht (court of registration) Stuttgart · HRA 590344

General partner Elektrobau Muldingen GmbH · Headquarters Muldingen

Amtsgericht (court of registration) Stuttgart · HRB 590142

Nominal data

Type	W1G200-EA91-35		
Motor	M1G055-BD		
Phase		1~	1~
Nominal voltage	VAC	230	230
Frequency	Hz	50/60	50/60
Method of obtaining data		ml	
Speed	min ⁻¹	1500	1400
Power consumption	W	14	-
Current draw	A	0.11	
Min. ambient temperature	°C	-30	-30
Max. ambient temperature	°C	50	50

ml = Max. load · me = Max. efficiency · fa = Free air · cs = Customer specification · ce = Customer equipment
Subject to change



EC axial fan

sickle-shaped blades (S series), single-intake

ESM fan housing

Technical description

Weight	1 kg
Fan size	200 mm
Rotor surface	Painted black
Blade material	Sheet steel, painted black
Fan housing material	PP plastic
Number of blades	5
Direction of rotation	"V"
Degree of protection	IP54; only with suitable plug, to be installed by customer
Insulation class	"B"
Max. permitted ambient temp. for motor (transport/storage)	+80 °C
Min. permitted ambient temp. for motor (transport/storage)	- 40 °C
Installation position	Any
Condensation drainage holes	None
Mode	S1
Motor bearing	Ball bearing
Technical features	<ul style="list-style-type: none"> - Speed setting input (230 V) - Soft start - Thermal overload protection for motor
Motor protection	Thermal overload protector (TOP) internally connected
With cable	Lateral
Protection class	II
Conformity with standards	EN 60335-1; EN 60335-2-24; EN 60335-2-80; EN 60335-2-89; CE
Approval	VDE; UL 2111; CSA C22.2 No. 77



EC axial fan

sickle-shaped blades (S series), single-intake

ESM fan housing

Product drawing

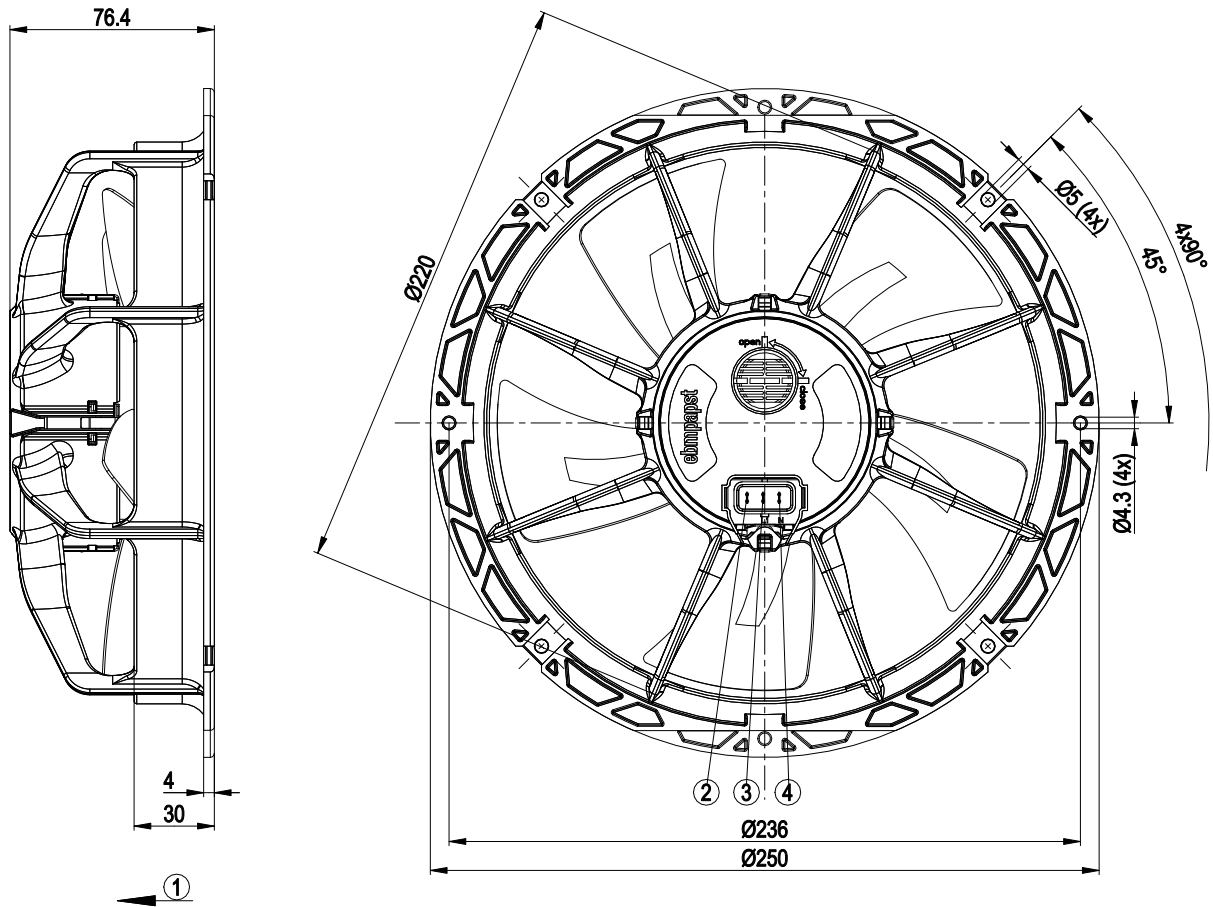

1	Direction of air flow "V"
2	Pin S, speed selection (flat plug 2.8 x 0.5)
3	Pin L1, phase (flat plug 2.8 x 0.5)
4	Pin N, neutral conductor (flat plug 2.8 x 0.5)

Connection diagram

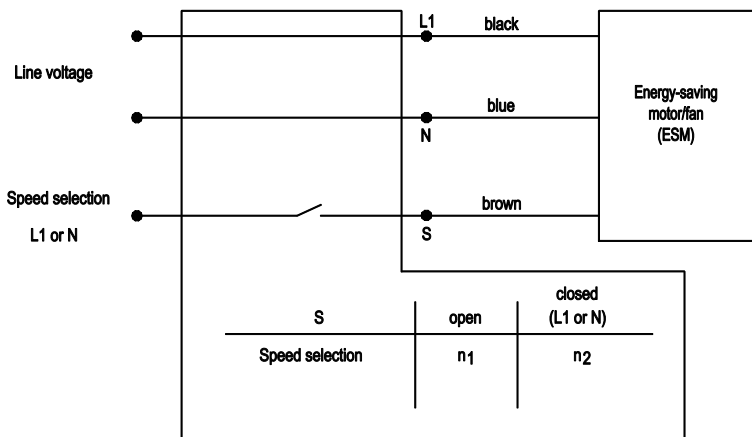

Curves: Air performance 50 Hz

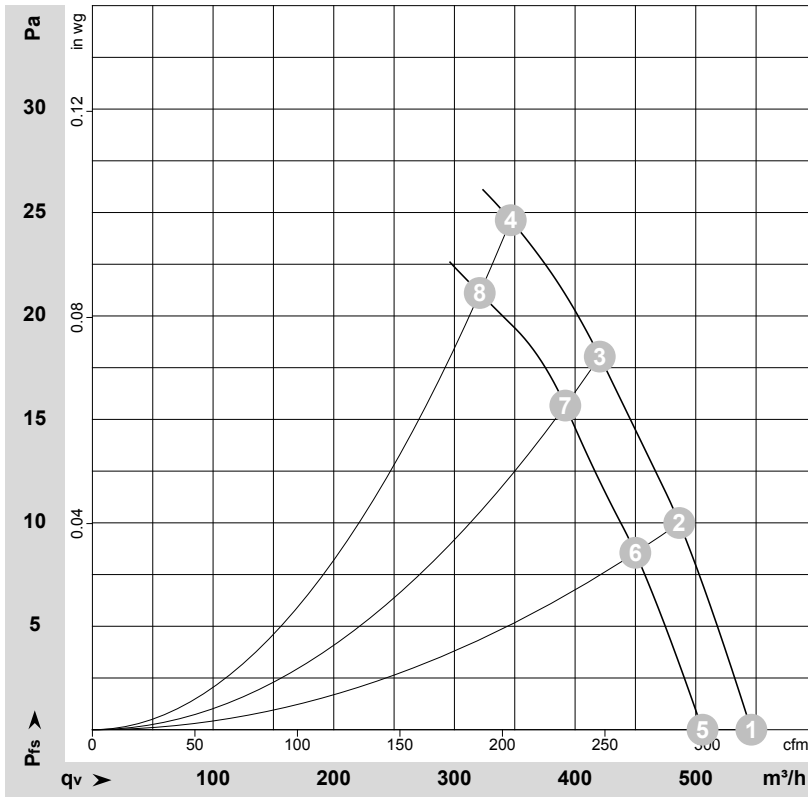

$\rho = 1.15 \text{ kg/m}^3 \pm 2 \%$

Measurement: LU-68033-1

Air performance measured according to ISO 5801 installation category A. For detailed information on the measurement setup, contact ebmpapst. Intake sound level: Sound power level according to ISO 13347 / sound pressure level measured at 1 m distance from fan axis. The values given are valid under the specified measuring conditions and may vary due to conditions of installation. For deviations from the standard configuration, the parameters have to be checked on the installed unit.

Measured values

	Stage	U	f	n	P _{ed}	I	q _v	p _{fs}
		V	Hz	min ⁻¹	W	A	m ³ /h	Pa
1	1	230	50	1500	13	0.10	545	0
2	1	230	50	1500	13	0.10	485	10
3	1	230	50	1500	14	0.10	420	18
4	1	230	50	1500	14	0.11	345	25
5	1	230	50	1400	10.0	0.08	505	0
6	1	230	50	1400	11	0.08	450	9
7	1	230	50	1400	11	0.08	390	16
8	1	230	50	1400	12	0.08	320	21

U = Power supply · f = Frequency · n = Speed · P_{ed} = Power consumption · I = Current draw · q_v = Air flow · p_{fs} = Pressure increase

