

W1G180-AB47-15 ebmpapst Datasheet

sales@fansco.com

www.fansco.com

Limited partnership · Headquarters Muldingen

Amtsgericht (court of registration) Stuttgart · HRA 590344

General partner Elektrobau Muldingen GmbH · Headquarters Muldingen

Amtsgericht (court of registration) Stuttgart · HRB 590142

## Nominal data

Type	W1G180-AB47-15	
Motor	M1G074-BF	
Nominal voltage	VDC	48
Nominal voltage range	VDC	36 .. 72
Method of obtaining data		fa
Speed (rpm)	min <sup>-1</sup>	4600
Power consumption	W	95
Current draw	A	2.27
Max. back pressure	Pa	275
Max. back pressure	in. wg	1.1
Min. ambient temperature	°C	-25
Max. ambient temperature	°C	60

ml = Max. load · me = Max. efficiency · fa = Free air · cs = Customer specification · ce = Customer equipment  
Subject to change



### Technical description

<b>Weight</b>	2.0 kg
<b>Size</b>	180 mm
<b>Motor size</b>	74
<b>Rotor surface</b>	Painted black
<b>Impeller material</b>	PA plastic
<b>Fan housing material</b>	Die-cast aluminum, painted black
<b>Number of blades</b>	5
<b>Airflow direction</b>	V
<b>Direction of rotation</b>	Counterclockwise, viewed toward rotor
<b>Degree of protection</b>	IP44
<b>Insulation class</b>	"B"
<b>Moisture (F) / Environmental (H) protection class</b>	H2
<b>Max. permitted ambient temp. for motor (transport/storage)</b>	+80 °C
<b>Min. permitted ambient temp. for motor (transport/storage)</b>	-40 °C
<b>Installation position</b>	Any
<b>Condensation drainage holes</b>	None
<b>Mode</b>	S1
<b>Motor bearing</b>	Ball bearing
<b>Technical features</b>	<ul style="list-style-type: none"> <li>- Fault output (open collector)</li> <li>- Motor current limitation</li> <li>- Soft start</li> <li>- Reverse polarity protection</li> </ul>
<b>Motor protection</b>	Reverse polarity and locked-rotor protection
<b>With cable</b>	Lateral
<b>Conformity with standards</b>	EN 60034-1; EN 60204-1; EN 60335-1
<b>Approval</b>	UL 507; CCC; CSA C22.2 No. 113

## Product drawing

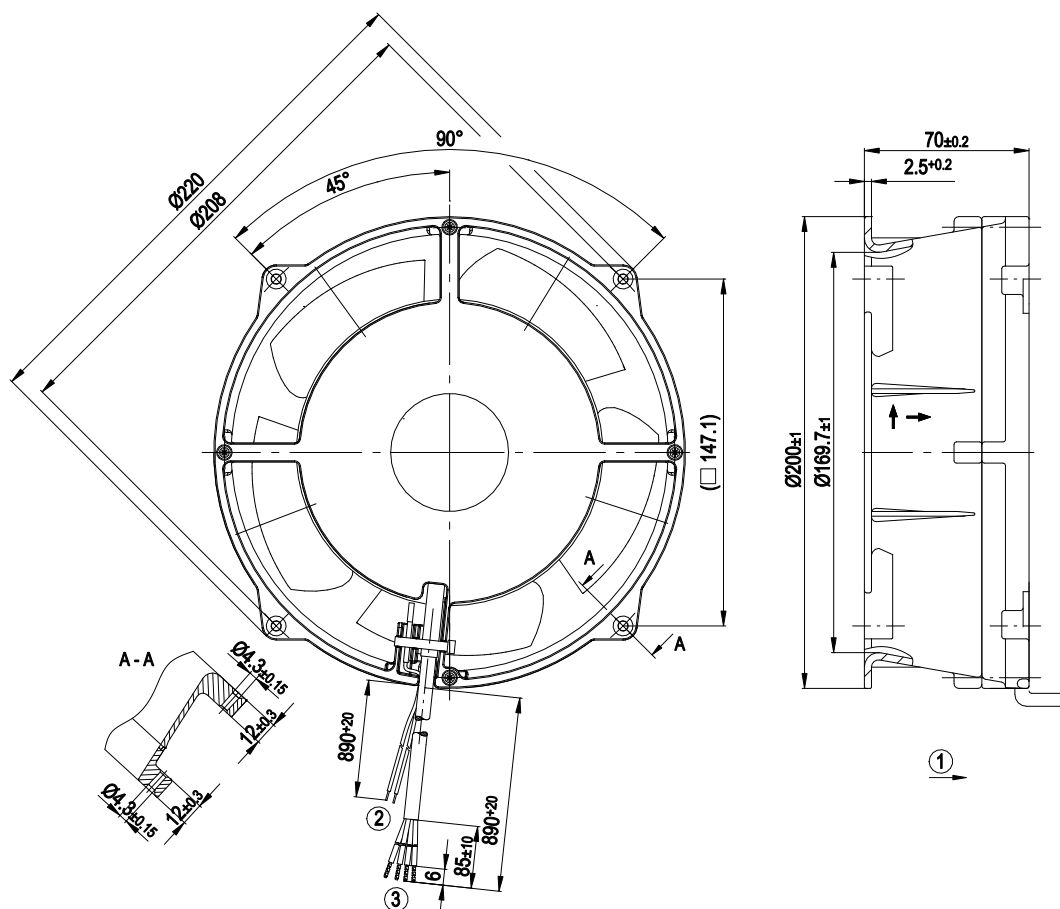

1	Airflow direction "V"
2	Cable AWG22 2x splice
3	Cable PVC AWG20 4x splice

# EC axial compact fan

sickle-shaped blades (S series)

## Connection diagram

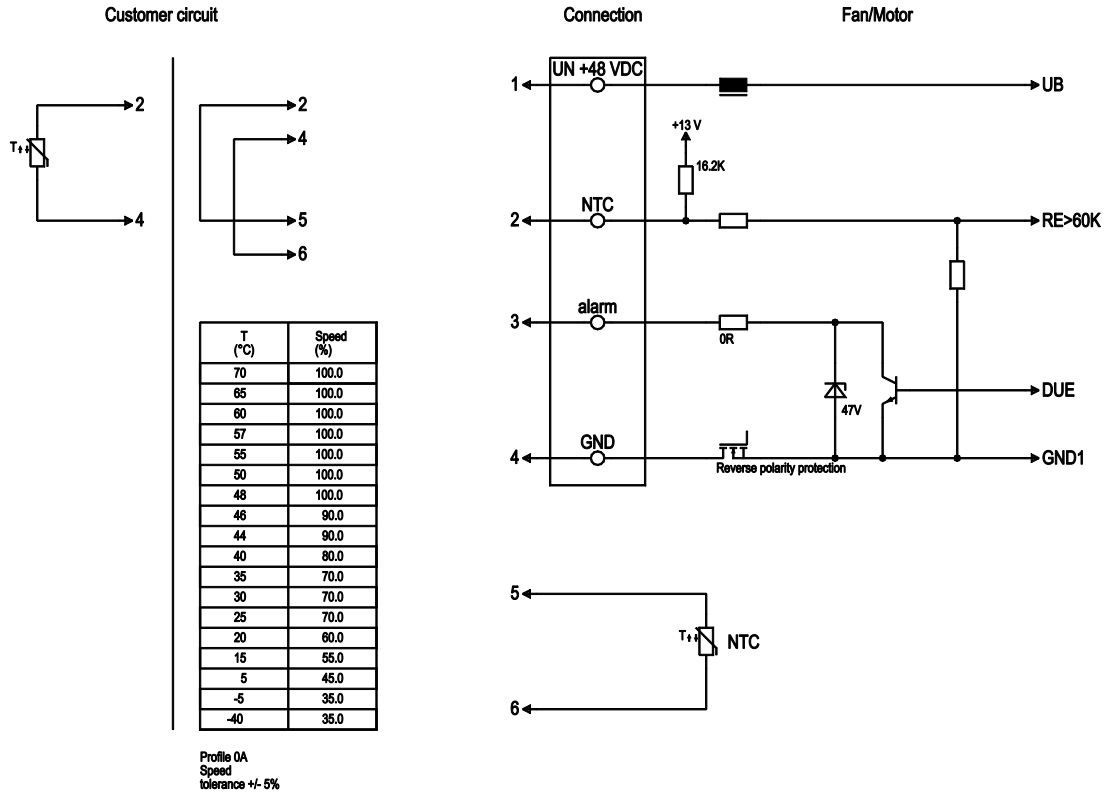

No.	Conn.	Designation	Color	Function/assignment
1	UN +48 VDC	red	Power supply, see nameplate for voltage range, maximum ripple 3.5%	
2	NTC	yellow	NTC control input	
3	alarm	white	Status output, open collector, fan good = high, Isink max = 10 mA	
4	GND	blue	Reference ground for control interface	
5	NTC	black	NTC	
6	NTC	black	NTC	



## Curves: Air performance

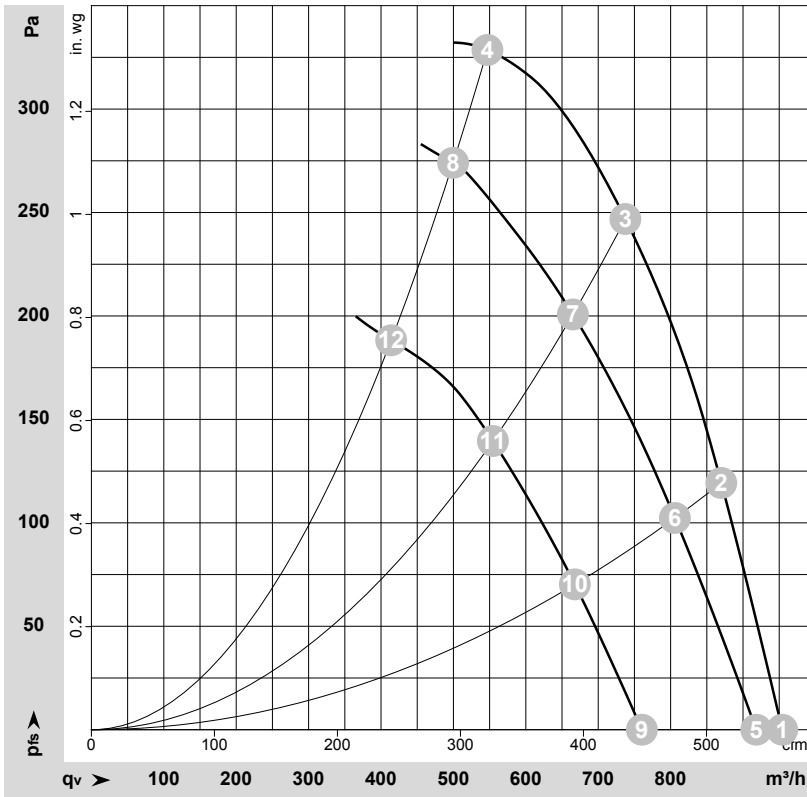

$\rho = 1.15 \text{ kg/m}^3 \pm 2 \%$

Measurement: LU-44620-1  
 Measurement: LU-44618-1  
 Measurement: LU-44617-1

Air performance measured according to ISO 5801 installation category A. For detailed information on the measurement setup, contact ebmpapst. Intake sound level: Sound power level according to ISO 13347 / sound pressure level measured at 1 m distance from fan axis. The values given are valid under the specified measuring conditions and may vary due to conditions of installation. For deviations from the standard configuration, the parameters have to be checked on the installed unit.

## Measured values

	U	n	P <sub>ed</sub>	I	q <sub>v</sub>	p <sub>fs</sub>	q <sub>v</sub>	p <sub>fs</sub>
	V	min <sup>-1</sup>	W	A	m <sup>3</sup> /h	Pa	cfm	in. wg
1	72	4810	109	2.21	955	0	560	0.00
2	72	4820	131	2.56	870	121	510	0.49
3	72	4815	148	2.84	735	247	435	0.99
4	72	4800	142	2.75	545	331	320	1.33
5	48	4600	95	2.27	920	0	540	0.00
6	48	4485	103	2.42	805	100	475	0.40
7	48	4345	109	2.56	665	200	390	0.80
8	48	4390	106	2.50	500	275	295	1.10
9	36	3845	57	1.80	760	0	445	0.00
10	36	3745	61	1.93	670	70	395	0.28
11	36	3650	66	2.05	555	140	325	0.56
12	36	3700	64	2.00	415	188	245	0.75

U = Voltage · n = Speed (rpm) · P<sub>ed</sub> = Power consumption · I = Current draw · q<sub>v</sub> = Air flow · p<sub>fs</sub> = Pressure increase

