



W1G180-AB31-41 ebmpapst Datasheet
 sales@fansco.com
 www.fansco.com

Limited partnership · Headquarters Muldingen
 Amtsgericht (court of registration) Stuttgart · HRA 590344

General partner Elektrobau Muldingen GmbH · Headquarters Muldingen
 Amtsgericht (court of registration) Stuttgart · HRB 590142

Nominal data

Type	W1G180-AB31-41	
Motor	M1G074-BF	
Nominal voltage	VDC	24
Nominal voltage range	VDC	16 .. 28
Method of obtaining data		fa
Speed (rpm)	min ⁻¹	4550
Power consumption	W	93
Current draw	A	4.3
Max. back pressure	Pa	380
Max. back pressure	inH ₂ O	1.53
Min. ambient temperature	°C	-25
Max. ambient temperature	°C	60

ml = Max. load · me = Max. efficiency · fa = Free air · cs = Customer specification · ce = Customer equipment
 Subject to change



Technical description

Weight	2 kg
Fan size	180 mm
Rotor surface	Painted black
Impeller material	PA66 plastic, glass-fiber reinforced
Fan housing material	Die-cast aluminum, painted black
Number of blades	5
Airflow direction	"V"
Direction of rotation	Counterclockwise, viewed toward rotor
Degree of protection	IP20
Insulation class	"B"
Moisture (F) / Environmental (H) protection class	F0
Max. permitted ambient temp. for motor (transport/storage)	+80 °C
Min. permitted ambient temp. for motor (transport/storage)	-40 °C
Installation position	Any
Condensation drainage holes	None
Mode	S1
Motor bearing	Ball bearing
Technical features	<ul style="list-style-type: none"> - Control input 0-10 VDC / PWM - Tach output - Motor current limitation - Soft start
EMC immunity to interference	According to EN 61000-6-2 (industrial environment)
EMC interference emission	According to EN 55022 (Class B)
Motor protection	Reverse polarity and locked-rotor protection
With cable	Lateral
Conformity with standards	EN 60950-1
Approval	CSA C22.2 No. 113; UL 507

Product drawing

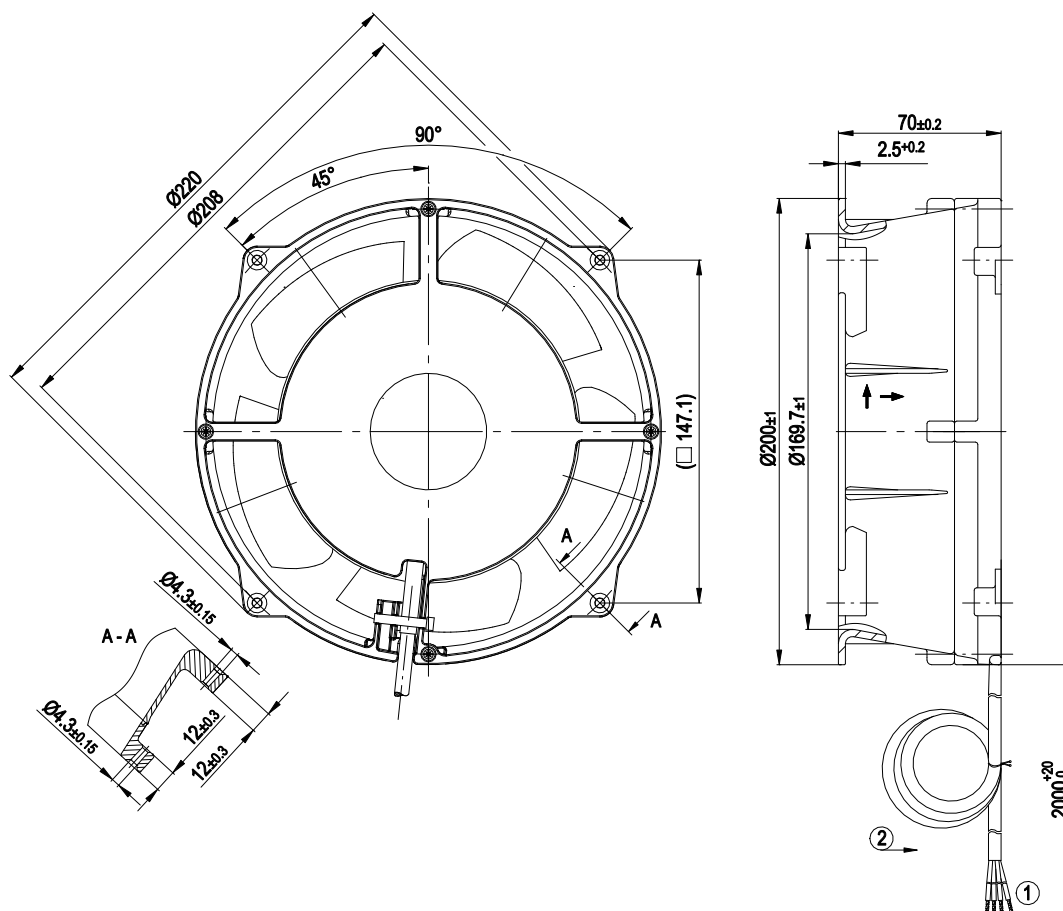

- | | |
|---|----------------------------------|
| 1 | Cable AWG 20, 4x crimped splices |
| 2 | Airflow direction "V" |



Connection diagram

Customer circuit

Full speed

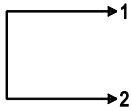

Adjustable speed

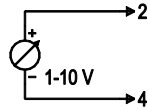

10 V → n = max
1 V → n = min
< 1 V → n = 0
Safe start at Unom -30% from 4 V Ucontr.

Speed adjustable via potentiometer

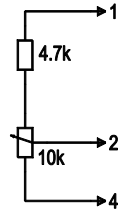

Speed adjustable via PWM 1-10 kHz

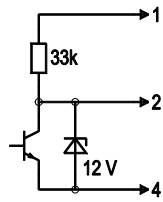

100% PWM → n = max
10% PWM → n = min
< 10% PWM → n = 0
Safe start at Unom -30% from 40% PWM

Set value requirement via temperature controller

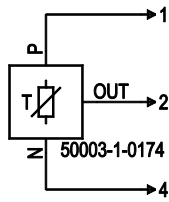

T < 10 °C → n = 0
T > 45 °C → n = max

Connection

Fan / Motor

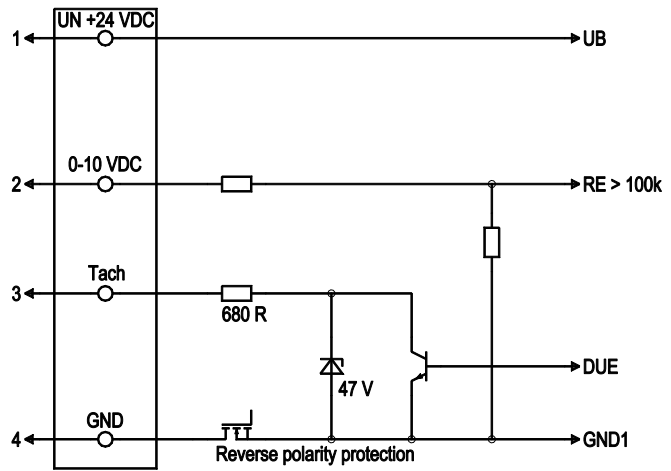

No.	Conn.	Designation	Color	Function/assignment
1	1	Un +24 VDC	red	Power supply 24 VDC, maximum ripple 3.5 %
1	2	0-10 VDC	yellow	Control input Re > 100k
1	3	Tach	white	Tach output, 3 pulses per revolution, Isink max = 10 mA
1	4	GND	blue	Reference ground



Curves: Air performance

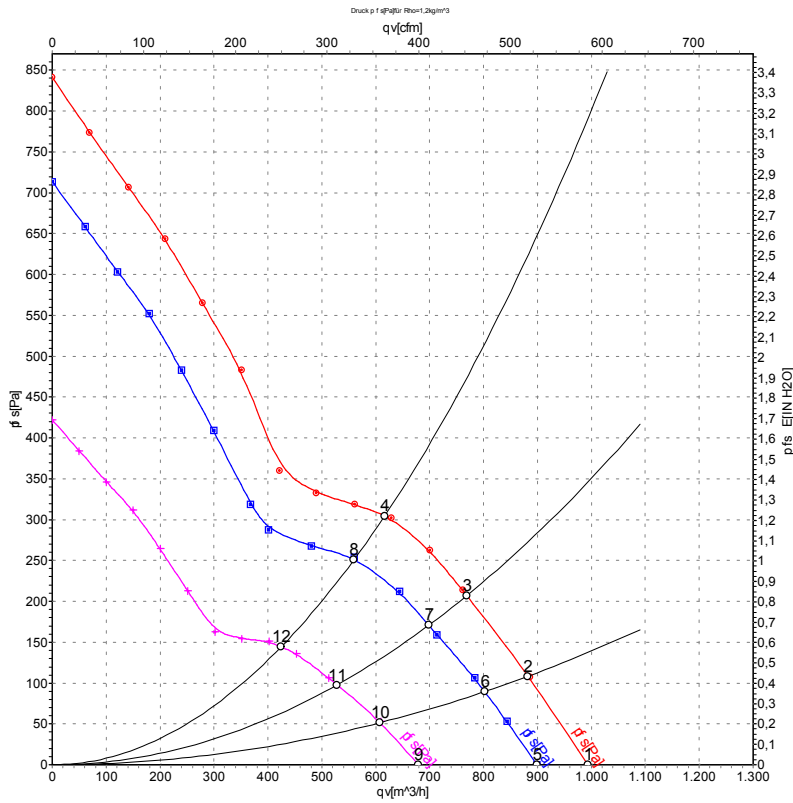

Measurement: LU-76822-1
 Measurement: LU-76821-1
 Measurement: LU-76825-1

Air performance measured according to ISO 5801 installation category A. For detailed information on the measurement setup, contact ebmpapst. Intake sound level: Sound power level according to ISO 13347 / sound pressure level measured at 1 m distance from fan axis. The values given are valid under the specified measuring conditions and may vary due to conditions of installation. For deviations from the standard configuration, the parameters have to be checked on the installed unit.

Measured values

	U	n	P _{ed}	I	qv	p _{fs}	qv	p _{fs}
	V	min ⁻¹	W	A	m ³ /h	Pa	CFM	inH ₂ O
1	28	5060	127	5.02	995	0	585	0.00
2	28	4900	133	5.31	880	111	520	0.45
3	28	4780	139	5.57	770	208	455	0.84
4	28	4750	140	5.64	615	305	365	1.22
5	24	4550	93	4.30	900	0	530	0.00
6	24	4460	102	4.73	800	90	470	0.36
7	24	4350	106	4.93	700	170	410	0.68
8	24	4325	108	5.00	560	250	330	1.00
9	16	3465	45	3.27	680	0	400	0.00
10	16	3370	48	3.41	610	54	360	0.22
11	16	3315	49	3.52	530	98	310	0.39
12	16	3300	50	3.55	425	144	250	0.58

U = Power supply · n = Speed (rpm) · P_{ed} = Power consumption · I = Current draw · qv = Air flow · p_{fs} = Pressure increase

