

EC axial fan

sickle-shaped blades (S series)

ESM fan housing

W1G172-EC91-16 ebmpapst Datasheet

sales@fansco.com

www.fansco.com

Limited partnership · Headquarters Muldingen

Amtsgericht (court of registration) Stuttgart · HRA 590344

General partner Elektrobau Muldingen GmbH · Headquarters Muldingen

Amtsgericht (court of registration) Stuttgart · HRB 590142

Nominal data

Type	W1G172-EC91-16		
Motor	M1G055-BD		
Phase		1~	1~
Nominal voltage	VAC	230	230
Frequency	Hz	50/60	50/60
Method of obtaining data		ml	ml
Speed (rpm)	min ⁻¹	2500	1700
Power consumption	W	22	-
Current draw	A	0.18	-
Min. ambient temperature	°C	-40	-40
Max. ambient temperature	°C	50	50

ml = Max. load · me = Max. efficiency · fa = Free air · cs = Customer specification · ce = Customer equipment
Subject to change



EC axial fan

sickle-shaped blades (S series)

ESM fan housing

Technical description

Weight	0.9 kg
Fan size	172 mm
Blade material	PA plastic
Fan housing material	PP plastic
Number of blades	5
Airflow direction	"V"
Direction of rotation	Counterclockwise, viewed toward rotor
Degree of protection	IP54
Insulation class	"B"
Moisture (F) / Environmental (H) protection class	H1
Max. permitted ambient temp. for motor (transport/storage)	+ 70 °C
Min. permitted ambient temp. for motor (transport/storage)	- 40 °C
Installation position	Any
Condensation drainage holes	None
Mode	S1
Motor bearing	Ball bearing with low-temperature lubricant
Technical features	<ul style="list-style-type: none"> - Speed setting input (230 V) - Soft start - Thermal overload protection for motor
Motor protection	Thermal overload protector (TOP) internally connected
With cable	Lateral
Protection class	II
Conformity with standards	EN 60335-1; EN 60335-2-24; EN 60335-2-80; EN 60335-2-89; CE
Approval	CSA C22.2 No. 77; VDE; UL 1004-3; EAC



EC axial fan

sickle-shaped blades (S series)

ESM fan housing

Product drawing

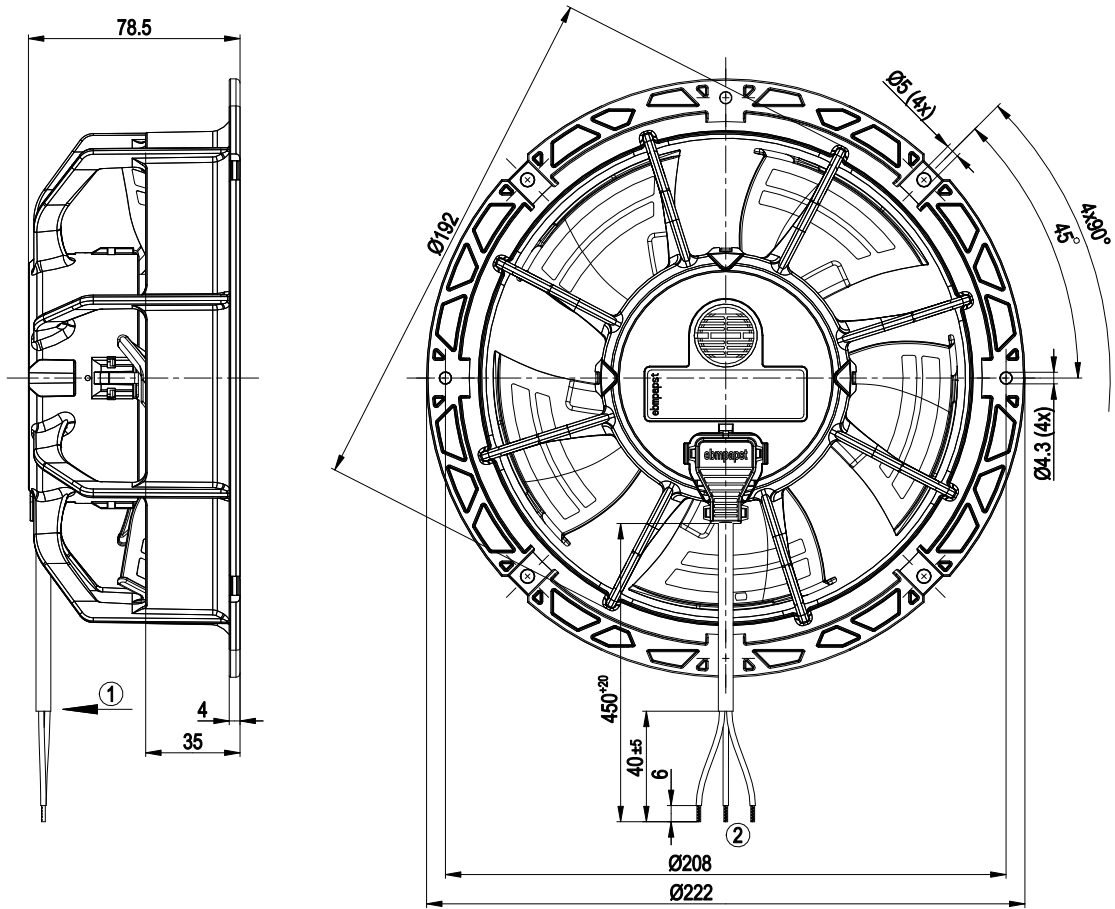

- 1 Airflow direction "V"
- 2 Cable PVC AWG20, 3x crimped splices

Connection diagram

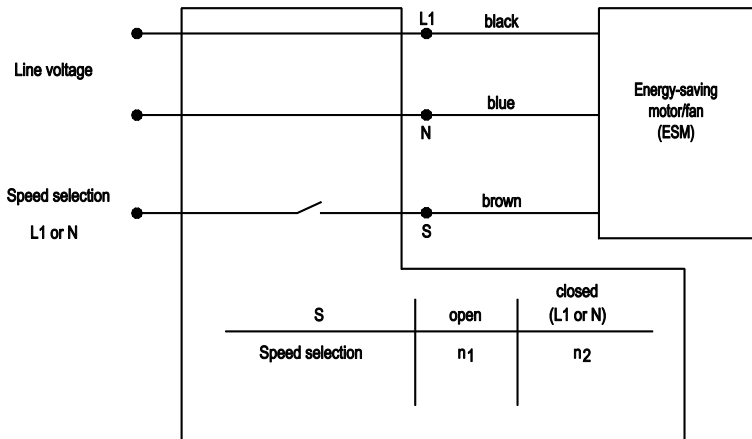

Curves: Air performance 50 Hz

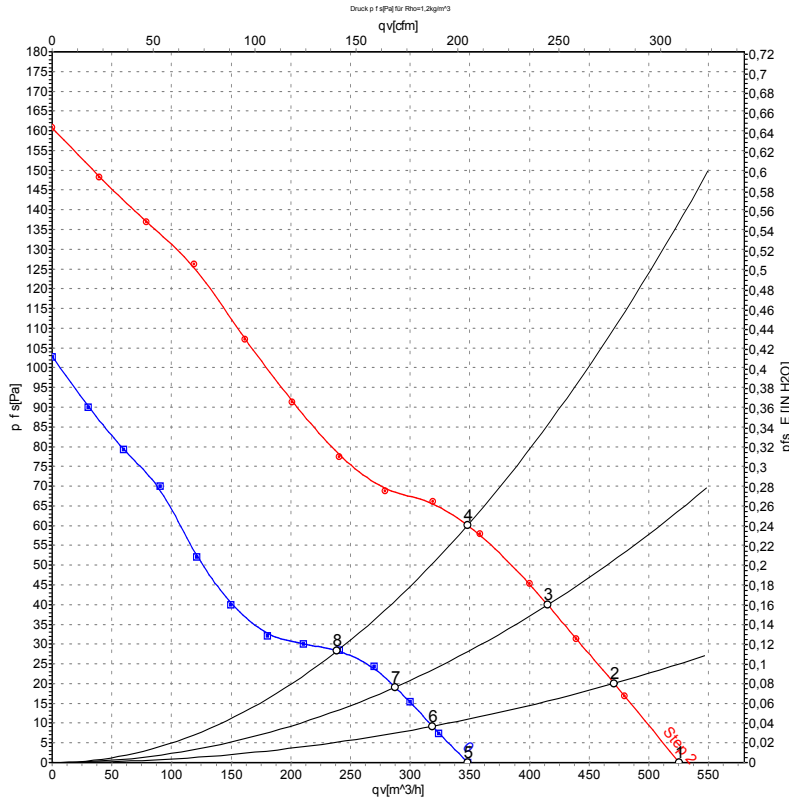

Measurement: LU-117884-1
Measurement: LU-117885-1

Air performance measured according to ISO 5801 installation category A. For detailed information on the measurement setup, contact ebm-papst. Intake sound level: Sound power level according to ISO 13347 / sound pressure level measured at 1 m distance from fan axis. The values given are valid under the specified measuring conditions and may vary due to conditions of installation. For deviations from the standard configuration, the parameters have to be checked on the installed unit.

Measured values

	Stage	U	f	n	P _{ed}	I	LpA _{in}	LwA _{in}	q _v	P _{fs}	q _v	P _{fs}
		V	Hz	min ⁻¹	W	A	dB(A)	dB(A)	m ³ /h	Pa	cfm	inH ₂ O
1	2	230	50	2500	21	0.17	54	62	525	0	310	0.00
2	2	230	50	2500	22	0.18	55	63	470	20	275	0.08
3	2	230	50	2500	22	0.18	54	63	415	40	245	0.16
4	2	230	50	2500	22	0.18	54	63	350	60	205	0.24
5	1	230	50	1700	8.8	0.07	45	54	350	0	205	0.00
6	1	230	50	1700	10	0.08	44	53	320	9	190	0.04
7	1	230	50	1700	11	0.08	44	53	285	19	170	0.08
8	1	230	50	1700	9.9	0.08	45	54	240	28	140	0.11

U = Power supply · f = Frequency · n = Speed (rpm) · P_{ed} = Power consumption · I = Current draw · LpA_{in} = Sound pressure level intake side · LwA_{in} = Sound power level intake side
q_v = Air flow · P_{fs} = Pressure increase

