

EC axial fan

sickle-shaped blades (S series), single-intake

ESM fan housing

W1G172-EC91-14 ebmpapst Datasheet

sales@fansco.com

www.fansco.com

Limited partnership · Headquarters Muldingen

Amtsgericht (court of registration) Stuttgart · HRA 590344

General partner Elektrobau Muldingen GmbH · Headquarters Muldingen

Amtsgericht (court of registration) Stuttgart · HRB 590142

Nominal data

Type	W1G172-EC91-14		
Motor	M1G055-BD		
Phase		1~	1~
Nominal voltage	VAC	230	230
Frequency	Hz	50/60	50/60
Method of obtaining data		ml	
Speed (rpm)	min ⁻¹	2400	1600
Power consumption	W	18	-
Current draw	A	0.13	
Min. ambient temperature	°C	-30	-30
Max. ambient temperature	°C	50	50

ml = Max. load · me = Max. efficiency · fa = Free air · cs = Customer specification · ce = Customer equipment
Subject to change



EC axial fan

sickle-shaped blades (S series), single-intake

ESM fan housing

Technical description

Weight	0.9 kg
Fan size	172 mm
Blade material	PA plastic
Fan housing material	PP plastic
Number of blades	5
Airflow direction	"V"
Direction of rotation	Right and left
Degree of protection	IP54; only with suitable plug, to be installed by customer
Insulation class	"B"
Moisture (F) / Environmental (H) protection class	H1
Max. permitted ambient temp. for motor (transport/storage)	+ 80 °C
Min. permitted ambient temp. for motor (transport/storage)	- 40 °C
Installation position	Any
Condensation drainage holes	None
Mode	S1
Motor bearing	Ball bearing
Technical features	<ul style="list-style-type: none"> - Automatic change in direction of rotation - Soft start - Thermal overload protection for motor
EMC immunity to interference	According to EN 61000-6-2 (industrial environment)
EMC circuit feedback	According to EN 61000-3-2/3
EMC interference emission	According to EN 61000-6-3 (household environment)
Motor protection	Thermal overload protector (TOP) internally connected
Protection class	II
Conformity with standards	EN 60335-1; EN 60335-2-24; EN 60335-2-80; EN 60335-2-89; CE
Approval	UL 1004-3; VDE; EAC; CSA C22.2 No. 77



EC axial fan

sickle-shaped blades (S series), single-intake

ESM fan housing

Product drawing

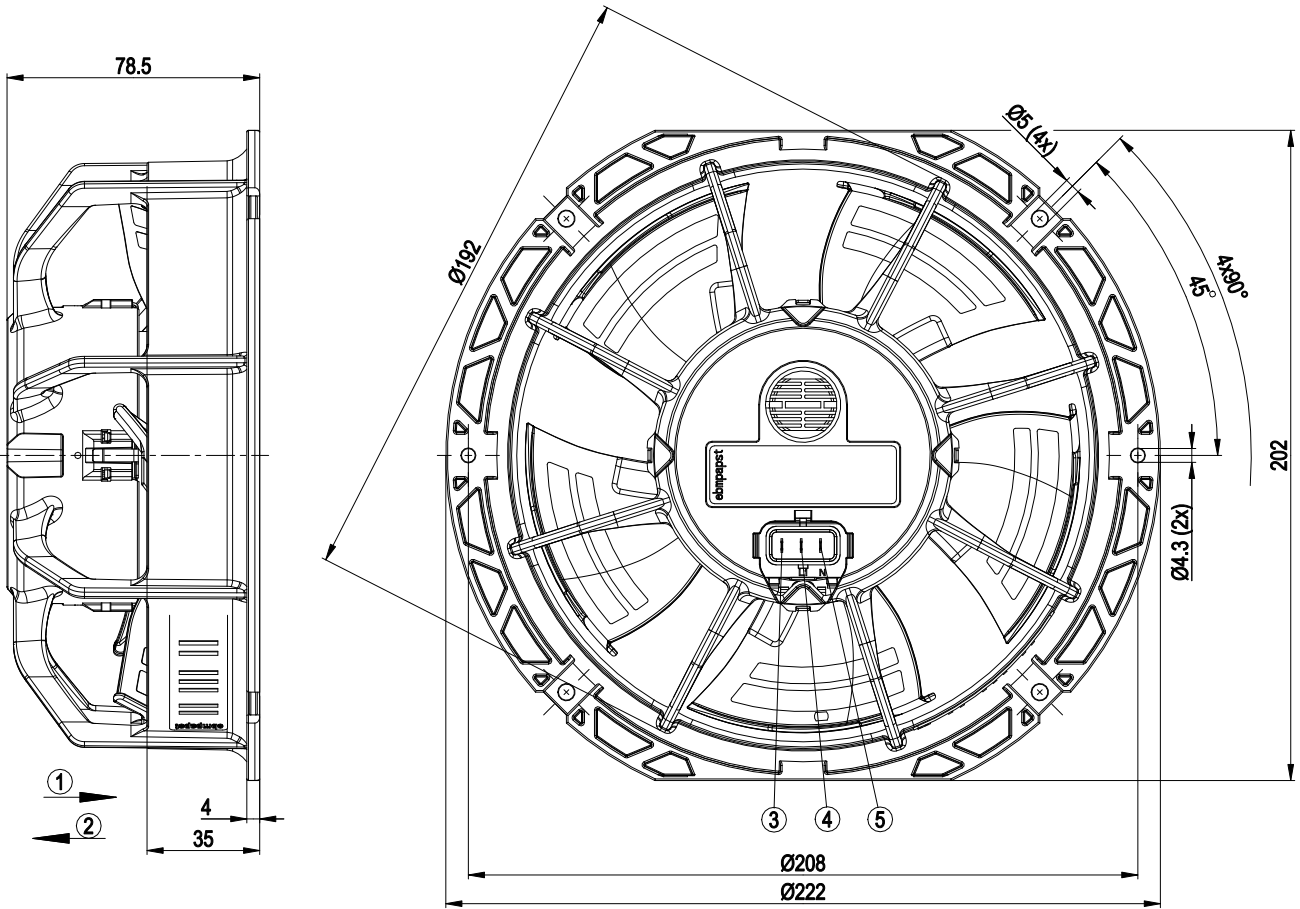

1	Airflow direction "A" when switched on for 30 sec. n = 1600 rpm, then automatic switchover to airflow direction "V"
2	Direction of air flow "V"
3	Pin S, speed selection (flat plug 2.8 x 0.5)
4	Pin L1, phase (flat plug 2.8 x 0.5)
5	Pin N, neutral conductor (flat plug 2.8 x 0.5)



EC axial fan

sickle-shaped blades (S series), single-intake
ESM fan housing

Connection diagram

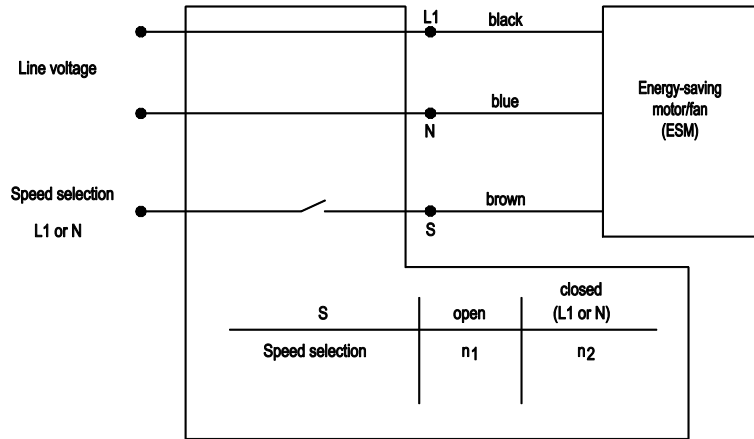

EC axial fan

sickle-shaped blades (S series), single-intake

ESM fan housing

Curves: Air performance 50 Hz

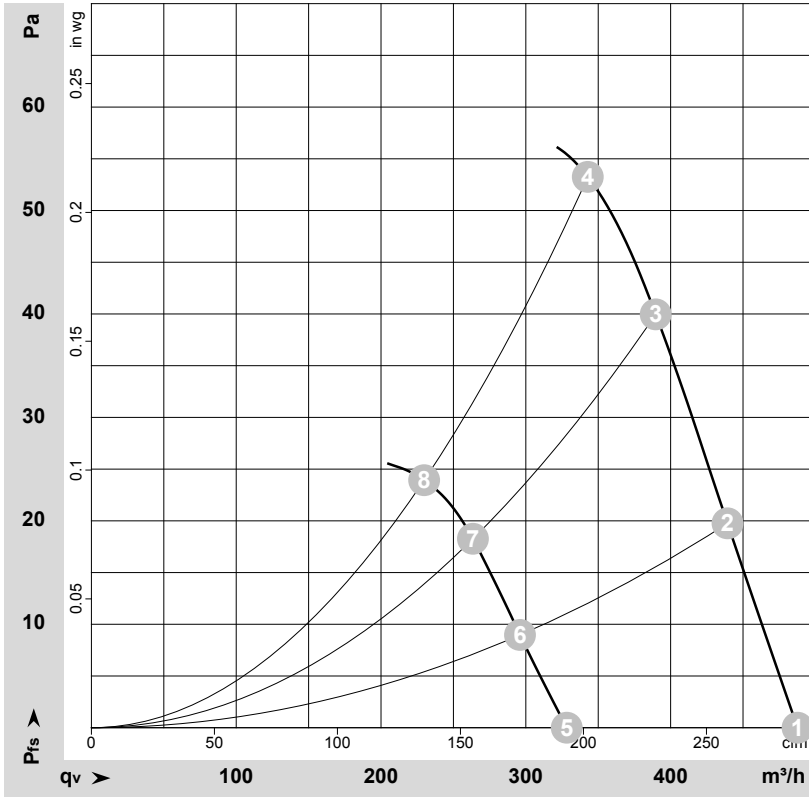

$\rho = 1.15 \text{ kg/m}^3 \pm 2 \%$

Measurement: LU-130336-1
Measurement: LU-171281-1

Air performance measured according to ISO 5801 installation category A. For detailed information on the measurement setup, contact ebm-papst. Intake sound level: Sound power level according to ISO 13347 / sound pressure level measured at 1 m distance from fan axis. The values given are valid under the specified measuring conditions and may vary due to conditions of installation. For deviations from the standard configuration, the parameters have to be checked on the installed unit.

Measured values

	Stage	U	f	n	P _{ed}	I	LpA _{in}	LwA _{in}	q _v	P _{fs}	q _v	P _{fs}
		V	Hz	min ⁻¹	W	A	dB(A)	dB(A)	m ³ /h	Pa	cfm	inH ₂ O
1		230	50	2400	18	0.13			490	0	285	0.00
2		230	50	2400	18	0.13			440	20	260	0.08
3		230	50	2400	18	0.13			390	40	230	0.16
4		230	50	2400	18	0.13			345	53	200	0.21
5	1	230	50	1600	7.0	0.06	43	52	330	0	195	0.00
6	1	230	50	1600	8.0	0.06	42	51	295	9	175	0.04
7	1	230	50	1600	9.0	0.07	42	51	265	18	155	0.07
8	1	230	50	1600	8.0	0.06	48	56	230	24	135	0.10

U = Power supply · f = Frequency · n = Speed (rpm) · P_{ed} = Power consumption · I = Current draw · LpA_{in} = Sound pressure level intake side · LwA_{in} = Sound power level intake side
q_v = Air flow · P_{fs} = Pressure increase

