



W1G130-AA49-17 ebmpapst Datasheet
sales@fansco.com
www.fansco.com

Limited partnership · Headquarters Mulfingen
 Amtsgericht (court of registration) Stuttgart · HRA 590344

General partner Elektrobau Mulfingen GmbH · Headquarters Mulfingen
 Amtsgericht (court of registration) Stuttgart · HRB 590142

Nominal data

Type	W1G130-AA49-17		
Motor	M1G055-AI		
Phase		1~	1~
Nominal voltage	VAC	115	115
Frequency	Hz	50/60	50/60
Method of obtaining data		ml	
Speed (rpm)	min ⁻¹	2800	2400
Power consumption	W	15	
Current draw	A	0.24	
Max. back pressure	Pa	65	
Max. back pressure	in. wg	0.26	
Min. ambient temperature	°C	-30	-30
Max. ambient temperature	°C	60	60

ml = Max. load · me = Max. efficiency · fa = Free air · cs = Customer specification · ce = Customer equipment
 Subject to change



Technical description

Weight	0.72 kg
Size	130 mm
Motor size	55
Blade material	PA plastic
Fan housing material	Plastic, PP
Number of blades	7
Airflow direction	V
Direction of rotation	Counterclockwise, viewed toward rotor
Degree of protection	IP55
Insulation class	"B"
Moisture (F) / Environmental (H) protection class	H1+
Max. permitted ambient temp. for motor (transport/storage)	+ 80 °C
Min. permitted ambient temp. for motor (transport/storage)	- 40 °C
Installation position	Any
Condensation drainage holes	None
Mode	S1
Motor bearing	Ball bearing
Technical features	<ul style="list-style-type: none"> - Speed setting input - Soft start - Thermal overload protection for motor
Speed levels	2
EMC immunity to interference	According to EN 61000-6-2 (industrial environment)
EMC interference emission	According to EN 61000-6-3 (household environment)
Electrical hookup	Connector with cable
Motor protection	Thermal overload protector (TOP) internally connected
With cable	Lateral
Protection class	II
Conformity with standards	EN 60034-1; EN 60204-1
Approval	CSA C22.2 No. 77 + CAN/CSA-E60730-1; EAC; UL 1004-3 + 60730-1



Product drawing

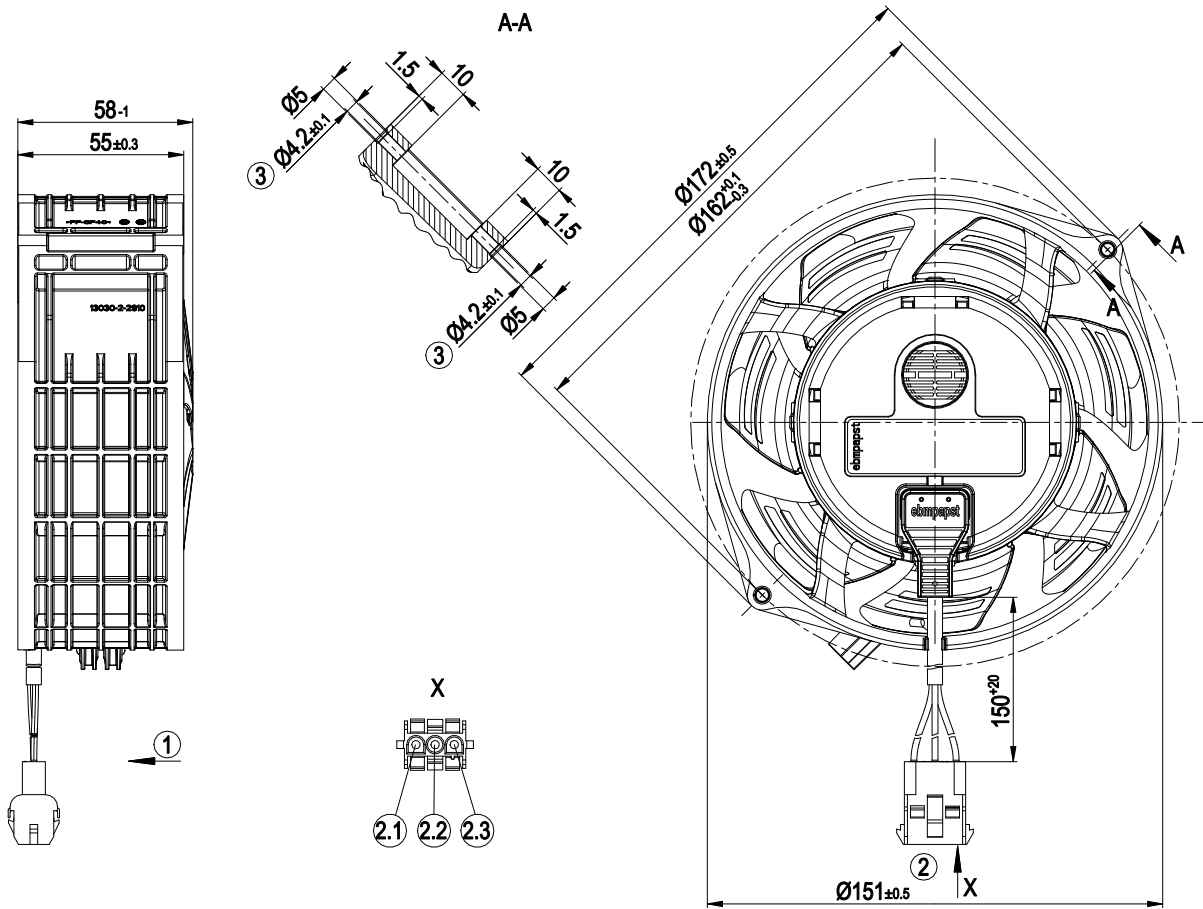

1	Airflow direction "V"
2	Cable PVC AWG20 3-pole connector housing TE 1-480701-0, 3x plug pin TE 350218-1
2.1	L (black)
2.2	N (blue)
2.3	S (brown)
3	Use is preferably to be made of 2x Remform screw WN-156-2 5.0x16 Torx galvanized (Arnold). Alternatively 2x metric bolt M4, fastening with nut



Connection diagram

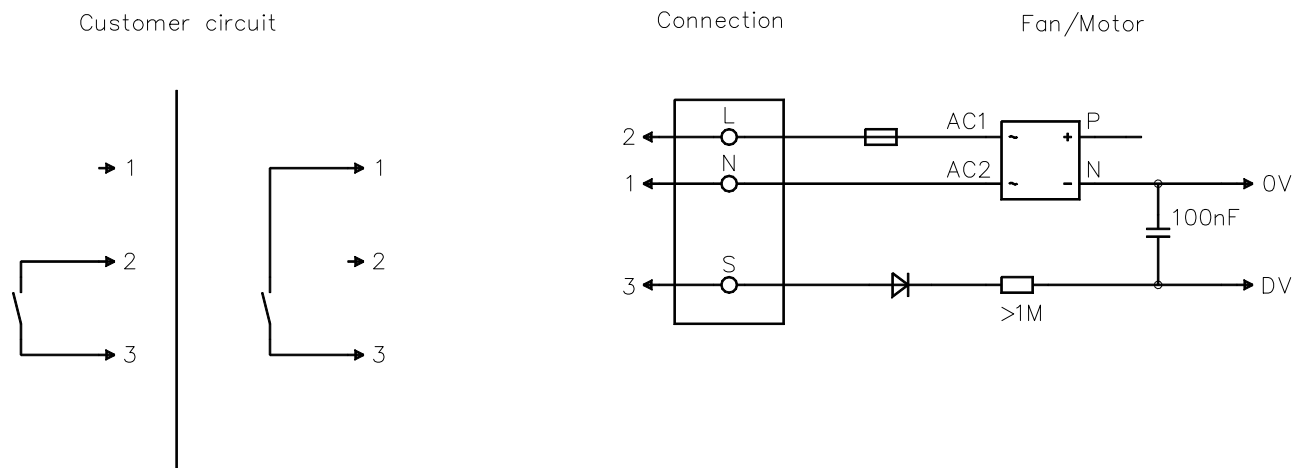

No.	Conn.	Designation	Color	Function/assignment
1	N		blue	Neutral conductor
2	L		black	Power supply 115 VAC, 50-60 Hz, see nameplate for voltage range
3	S		brown	Speed selection: switch open speed 1 (fast), switch closed speed 2 (slow)



Curves: Air performance 60 Hz

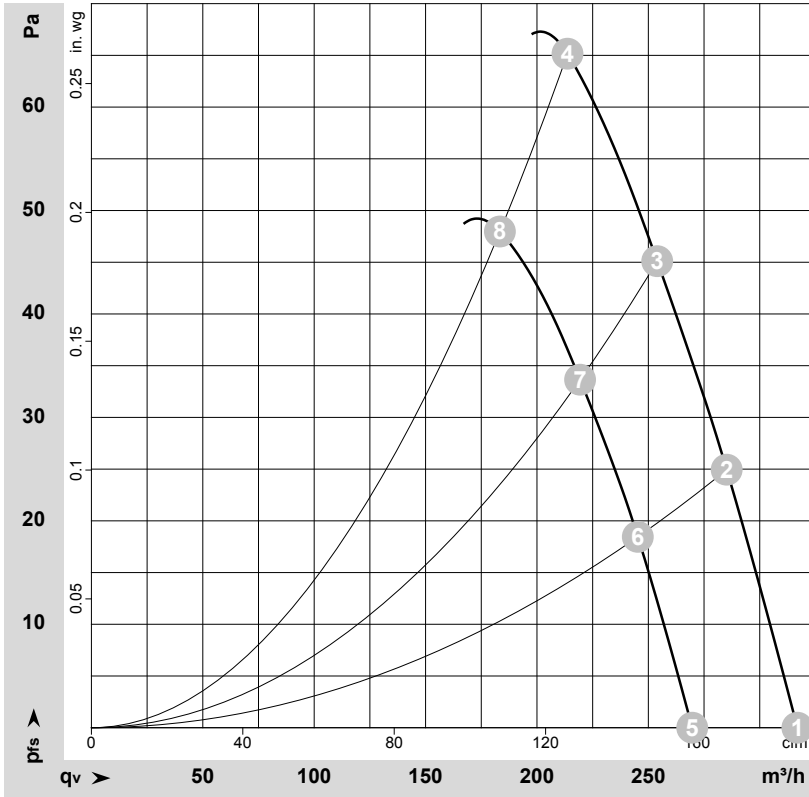

$\rho = 1.15 \text{ kg/m}^3 \pm 2 \%$

Measurement: LU-152098-1
Measurement: LU-187192-1

Air performance measured according to ISO 5801 installation category A. For detailed information on the measurement setup, contact ebmpapst. Intake sound level: Sound power level according to ISO 13347 / sound pressure level measured at 1 m distance from fan axis. The values given are valid under the specified measuring conditions and may vary due to conditions of installation. For deviations from the standard configuration, the parameters have to be checked on the installed unit.

Measured values

	U	f	n	P _{ed}	I	LpA _{in}	LwA _{in}	q _v	p _{fs}	q _v	p _{fs}
	V	Hz	min ⁻¹	W	A	dB(A)	dB(A)	m ³ /h	Pa	cfm	in. wg
1	115	60	2800	15	0.24	54	61	315	0	185	0.00
2	115	60	2800	15	0.24	54	61	285	25	170	0.10
3	115	60	2800	15	0.24	54	61	255	45	150	0.18
4	115	60	2800	15	0.24	54	61	215	65	125	0.26
5	115	60	2400	9.0	0.15	50	57	270	0	160	0.00
6	115	60	2400	10.0	0.15	50	57	245	19	145	0.08
7	115	60	2400	10.0	0.16	50	57	220	34	130	0.14
8	115	60	2400	10.0	0.15	51	57	185	48	110	0.19

U = Voltage · f = Frequency · n = Speed (rpm) · P_{ed} = Power consumption · I = Current draw · LpA_{in} = Sound pressure level intake side · LwA_{in} = Sound power level intake side
q_v = Air flow · p_{fs} = Pressure increase

