

AC axial fan - HyBlade

sickle-shaped blades (S series)

with round full nozzle

SZD800-AG03-01 ebmpapst Datasheet

sales@fansco.com

www.fansco.com

Limited partnership · Headquarters Mulfingen

Amtsgericht (court of registration) Stuttgart · HRA 590344

General partner Elektrobau Mulfingen GmbH · Headquarters Mulfingen

Amtsgericht (court of registration) Stuttgart · HRB 590142

Nominal data

Type	SZD800-AG03-01				
Motor	MZD138-HF				
Phase		3~	3~	3~	3~
Nominal voltage	VAC	400	400	480	480
Wiring		Δ	Y	Δ	Y
Frequency	Hz	50	50	60	60
Method of obtaining data		ml	ml	ml	ml
Valid for approval/standard		-	-	-	-
Speed	min ⁻¹	435	340	510	370
Power consumption	W	360	200	520	270
Current draw	A	1.12	0.47	1.2	0.54
Max. back pressure	Pa	40	23	52	27
Min. ambient temperature	°C	-40	-40	-40	-40
Max. ambient temperature	°C	70	70	65	65
Starting current	A	2.2		2.2	

ml = Max. load · me = Max. efficiency · fa = Free air · cs = Customer specification · ce = Customer equipment
 Subject to change



AC axial fan - HyBlade

sickle-shaped blades (S series)

with round full nozzle

Technical description

Weight	29.2 kg
Fan size	800 mm
Rotor surface	Cast in aluminum
Terminal box material	PP plastic
Blade material	Sheet aluminum insert, sprayed with PP plastic
Guard grille material	Steel, coated with black plastic (RAL 9005)
Number of blades	5
Blade pitch	0°
Airflow direction	"V"
Direction of rotation	Clockwise, viewed toward rotor
Degree of protection	IP54
Insulation class	"F"
Moisture (F) / Environmental (H) protection class	F3-1
Max. permitted ambient temp. for motor (transport/storage)	+80 °C
Min. permitted ambient temp. for motor (transport/storage)	-40 °C
Installation position	Any
Condensation drainage holes	On rotor and stator sides
Mode	S1
Motor bearing	Ball bearing
Touch current according to IEC 60990 (measuring circuit Fig. 4, TN system)	<= 3.5 mA
Electrical hookup	Via terminal box
Motor protection	Thermal overload protector (TOP) with basic insulation
With cable	Axial
Protection class	I (with customer connection of protective earth)
Conformity with standards	EN 60034; EN 61800-5-1
Approval	EAC; VDE



SZD800-AG03-01

AC axial fan - HyBlade

sickle-shaped blades (S series)

with round full nozzle

Product drawing

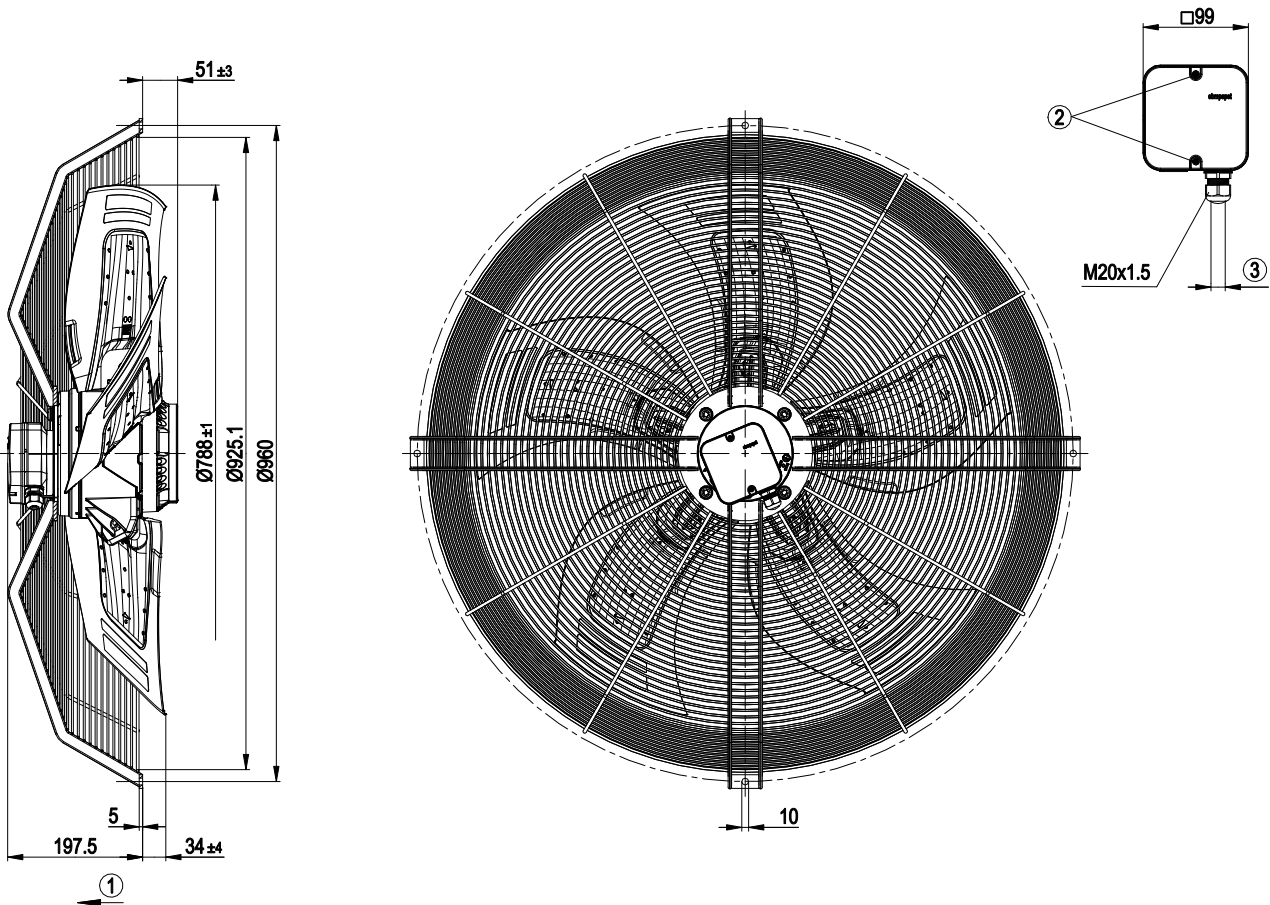

1	Direction of air flow "V"
2	Tightening torque 1.5 ± 0.2 Nm
3	Cable diameter min. 7 mm, max. 14 mm, tightening torque 2 ± 0.3 Nm



AC axial fan - HyBlade

sickle-shaped blades (S series)

with round full nozzle

Connection diagram



Δ	Delta connection	Y	Star connection	L1	= U1 = black
L2	= V1 = blue	L3	= W1 = brown	W2	yellow
U2	green	V2	white	TOP	2x gray
PE	green/yellow				



Curves: Air performance 50 Hz

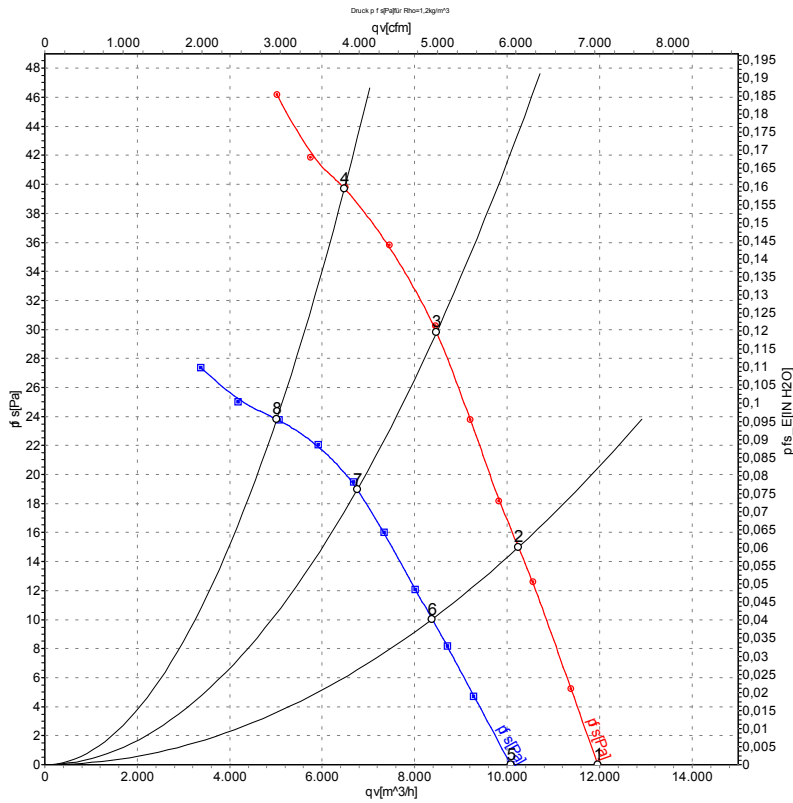

Measurement: LU-115875-1
Measurement: LU-115886-1

Air performance measured according to ISO 5801 installation category A. For detailed information on the measurement setup, contact ebm-papst. Intake sound level: Sound power level according to ISO 13347 / sound pressure level measured at 1 m distance from fan axis. The values given are valid under the specified measuring conditions and may vary due to conditions of installation. For deviations from the standard configuration, the parameters have to be checked on the installed unit.

Measured values

	Wired	U	f	n	P _e	I	LpA _{in}	LwA _{in}	LwA _{out}	qv	p _{fs}
		V	Hz	min ⁻¹	W	A	dB(A)	dB(A)	dB(A)	m ³ /h	Pa
1	Δ	400	50	460	292	1.09	50	56	55	11960	0
2	Δ	400	50	450	318	1.09	49	55	54	10250	15
3	Δ	400	50	445	336	1.10	49	55	55	8470	30
4	Δ	400	50	435	360	1.12	51	59	58	6480	40
5	Y	400	50	385	165	0.41	47	53	52	10080	0
6	Y	400	50	365	179	0.43	45	51	50	8380	10
7	Y	400	50	355	187	0.45	43	49	49	6760	19
8	Y	400	50	340	200	0.47	44	52	52	5020	24

Wired = Wiring · U = Power supply · f = Frequency · n = Speed · P_e = Power consumption · I = Current draw · LpA_{in} = Sound pressure level intake side · LwA_{in} = Sound power level intake side
LwA_{out} = Sound power level outlet side · qv = Air flow · p_{fs} = Pressure increase



Curves: Air performance 60 Hz

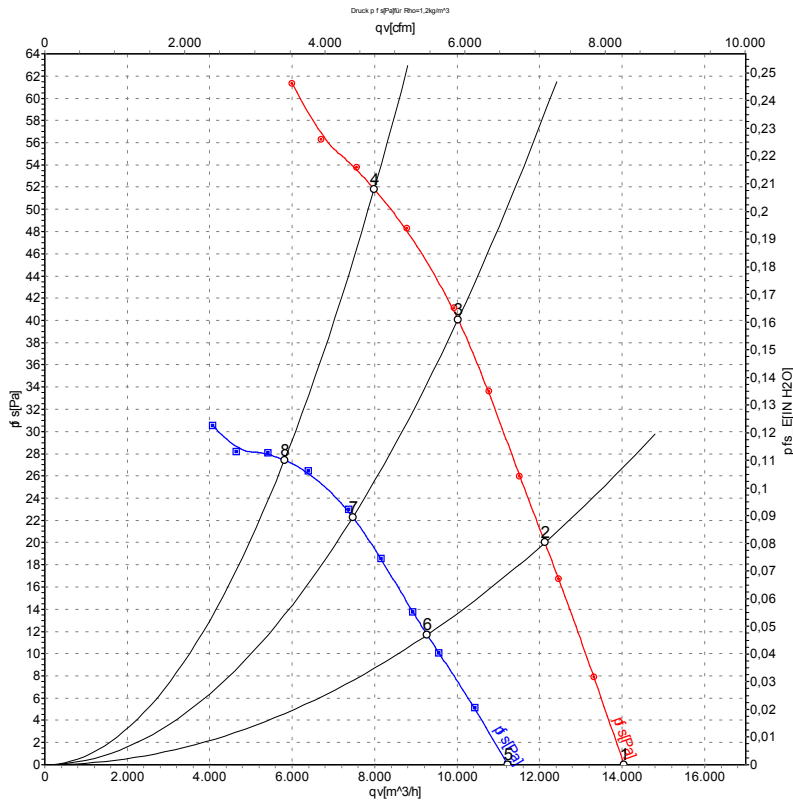

Measurement: LU-115881-1
Measurement: LU-115890-1

Air performance measured according to ISO 5801 installation category A. For detailed information on the measurement setup, contact ebm-papst. Intake sound level: Sound power level according to ISO 13347 / sound pressure level measured at 1 m distance from fan axis. The values given are valid under the specified measuring conditions and may vary due to conditions of installation. For deviations from the standard configuration, the parameters have to be checked on the installed unit.

Measured values

	Wired	U	f	n	P _e	I	LpA _{in}	LwA _{in}	LwA _{out}	qv	p _{fs}
		V	Hz	min ⁻¹	W	A	dB(A)	dB(A)	dB(A)	m ³ /h	Pa
1	Δ	480	60	540	415	1.13	53	59	59	14050	0
2	Δ	480	60	530	454	1.16	53	59	58	12130	20
3	Δ	480	60	520	484	1.17	53	59	59	10020	40
4	Δ	480	60	510	520	1.20	55	62	62	7990	52
5	Y	480	60	430	239	0.49	49	55	54	11220	0
6	Y	480	60	405	254	0.51	47	53	52	9275	12
7	Y	480	60	385	263	0.52	45	52	51	7470	22
8	Y	480	60	370	270	0.54	46	53	53	5810	27

Wired = Wiring · U = Power supply · f = Frequency · n = Speed · P_e = Power consumption · I = Current draw · LpA_{in} = Sound pressure level intake side · LwA_{in} = Sound power level intake side
LwA_{out} = Sound power level outlet side · qv = Air flow · p_{fs} = Pressure increase

