

# AC axial fan - HyBlade

sickle-shaped blades (S series)

with guard grille for full nozzle

S8D800-CD01-01 ebmpapst Datasheet

sales@fansco.com

www.fansco.com

Limited partnership · Headquarters Mulfingen

Amtsgericht (court of registration) Stuttgart · HRA 590344

General partner Elektrobau Mulfingen GmbH · Headquarters Mulfingen

Amtsgericht (court of registration) Stuttgart · HRB 590142

## Nominal data

Type	S8D800-CD01-01				
Motor	M8D138-LA				
Phase		3~	3~	3~	3~
Nominal voltage	VAC	400	400	480	480
Wiring		Δ	Y	Δ	Y
Frequency	Hz	50	50	60	60
Method of obtaining data		ml	ml	ml	ml
Valid for approval/standard		-	-	-	-
Speed	min <sup>-1</sup>	660	485	800	575
Power consumption	W	990	580	1270	740
Current draw	A	2.37	1.21	2.52	1.33
Max. back pressure	Pa	105	54	65	33
Min. ambient temperature	°C	-40	-40	-40	-40
Max. ambient temperature	°C	70	70	65	65
Starting current	A	6	2	6.6	2.2

ml = Max. load · me = Max. efficiency · fa = Free air · cs = Customer specification · ce = Customer equipment

Subject to change



# AC axial fan - HyBlade

sickle-shaped blades (S series)

with guard grille for full nozzle

## Technical description

Weight	31 kg
Fan size	800 mm
Rotor surface	Cast in aluminum
Terminal box material	PP plastic
Blade material	Sheet aluminum insert, sprayed with PP plastic
Guard grille material	Steel, coated with black plastic (RAL 9005)
Number of blades	5
Blade pitch	0°
Airflow direction	"V"
Direction of rotation	Clockwise, viewed toward rotor
Degree of protection	IP54
Insulation class	"F"
Moisture (F) / Environmental (H) protection class	F3-1
Max. permitted ambient temp. for motor (transport/storage)	+ 80 °C
Min. permitted ambient temp. for motor (transport/storage)	- 40 °C
Installation position	Any
Condensation drainage holes	On rotor and stator sides
Mode	S1
Motor bearing	Ball bearing
Touch current according to IEC 60990 (measuring circuit Fig. 4, TN system)	<= 3.5 mA
Electrical hookup	Via terminal box
Motor protection	Thermal overload protector (TOP) with basic insulation
With cable	Axial
Protection class	I (with customer connection of protective earth)
Conformity with standards	EN 60034-1 (2010); EN 61800-5-1
Approval	EAC; VDE



# AC axial fan - HyBlade

sickle-shaped blades (S series)

with guard grille for full nozzle

## Product drawing

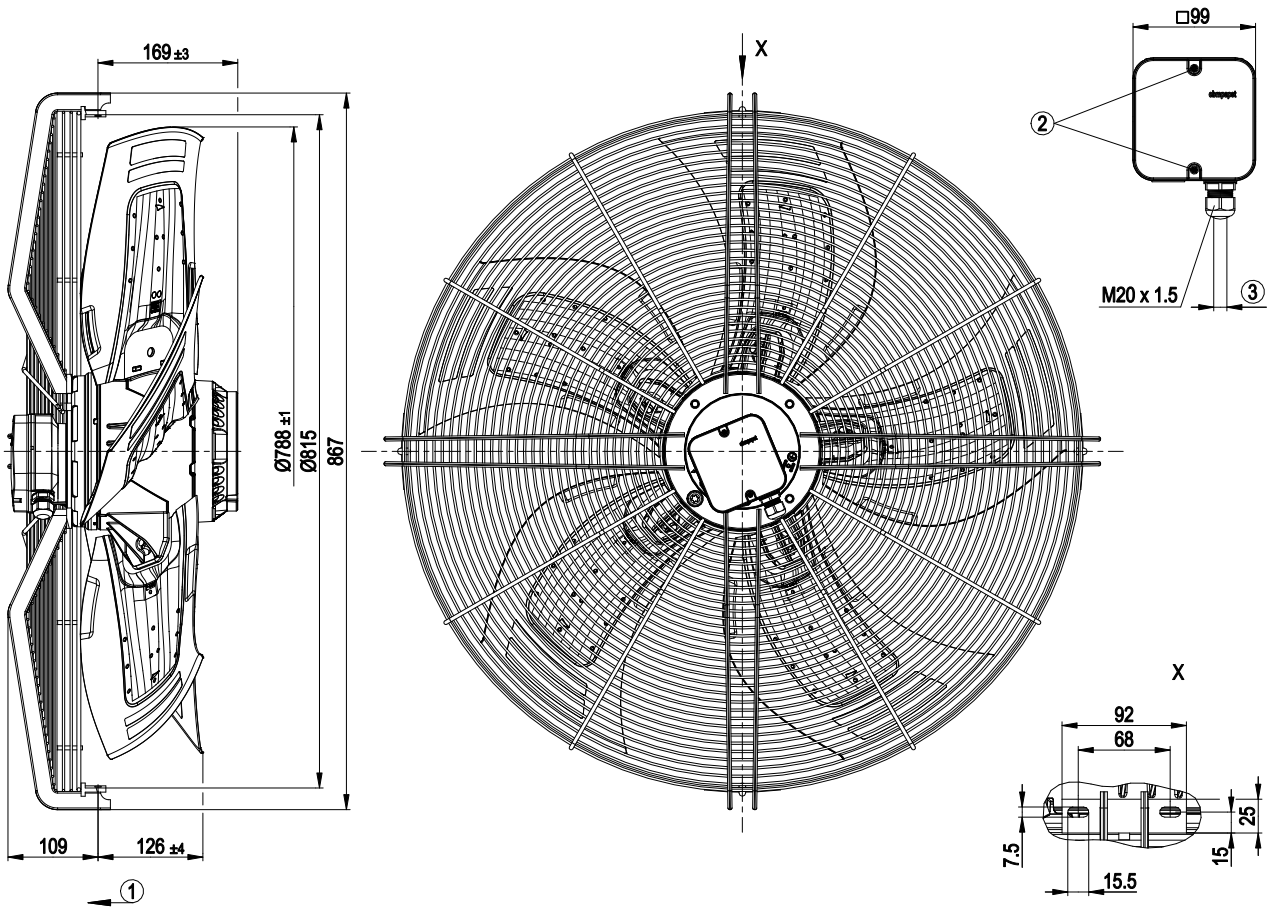

1	Direction of air flow "V"
2	Tightening torque 1.5 ± 0.2 Nm
3	Cable diameter min. 7 mm, max. 14 mm, tightening torque 2 ± 0.3 Nm



# AC axial fan - HyBlade

sickle-shaped blades (S series)

with guard grille for full nozzle

## Connection diagram



Δ	Delta connection	Y	Star connection	L1	= U1 = black
L2	= V1 = blue	L3	= W1 = brown	W2	yellow
U2	green	V2	white	TOP	2x gray
PE	green/yellow				



# AC axial fan - HyBlade

sickle-shaped blades (S series)

with guard grille for full nozzle

## Curves: Air performance 50 Hz

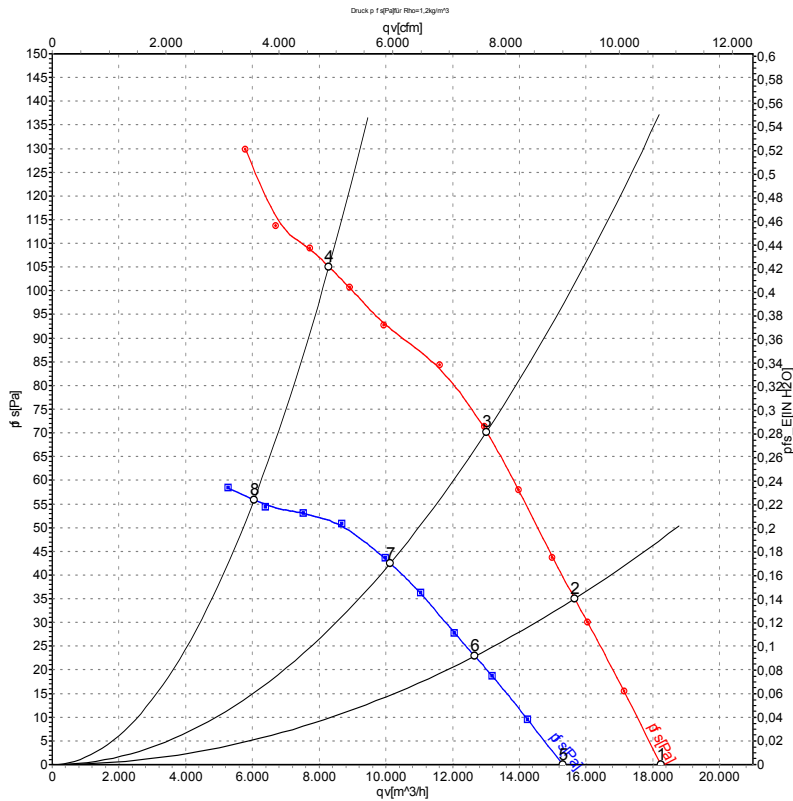

Measurement: LU-115898-1  
Measurement: LU-115925-1

Air performance measured according to ISO 5801 installation category A. For detailed information on the measurement setup, contact ebm-papst. Intake sound level: Sound power level according to ISO 13347 / sound pressure level measured at 1 m distance from fan axis. The values given are valid under the specified measuring conditions and may vary due to conditions of installation. For deviations from the standard configuration, the parameters have to be checked on the installed unit.

## Measured values

	Wired	U	f	n	P <sub>e</sub>	I	LpA <sub>in</sub>	LwA <sub>in</sub>	LwA <sub>out</sub>	qv	p <sub>fs</sub>
		V	Hz	min <sup>-1</sup>	W	A	dB(A)	dB(A)	dB(A)	m <sup>3</sup> /h	Pa
1	Δ	400	50	700	684	2.05	59	65	65	18240	0
2	Δ	400	50	685	771	2.10	59	65	64	15660	35
3	Δ	400	50	680	846	2.20	60	66	65	13020	70
4	Δ	400	50	660	990	2.37	66	74	74	8295	105
5	Y	400	50	585	466	0.98	55	61	61	15300	0
6	Y	400	50	555	510	1.07	54	60	59	12660	23
7	Y	400	50	530	534	1.12	53	60	59	10130	43
8	Y	400	50	485	580	1.21	58	66	66	6045	56

Wired = Wiring · U = Power supply · f = Frequency · n = Speed · P<sub>e</sub> = Power consumption · I = Current draw · LpA<sub>in</sub> = Sound pressure level intake side · LwA<sub>in</sub> = Sound power level intake side  
LwA<sub>out</sub> = Sound power level outlet side · qv = Air flow · p<sub>fs</sub> = Pressure increase



# AC axial fan - HyBlade

sickle-shaped blades (S series)

with guard grille for full nozzle

## Curves: Air performance 60 Hz

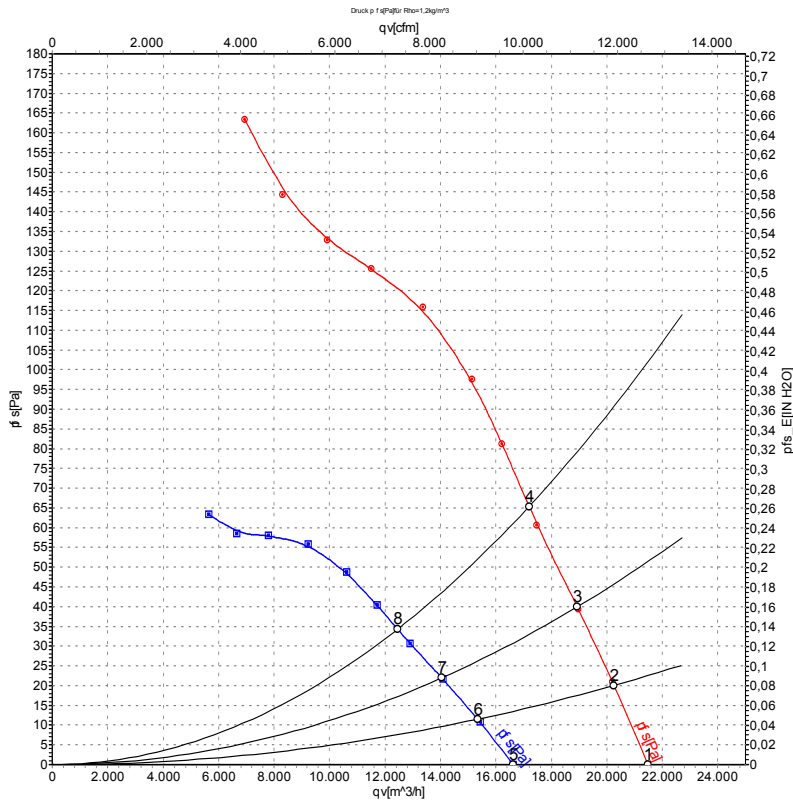

Measurement: LU-115907-1  
Measurement: LU-115926-1

Air performance measured according to ISO 5801 installation category A. For detailed information on the measurement setup, contact ebm-papst. Intake sound level: Sound power level according to ISO 13347 / sound pressure level measured at 1 m distance from fan axis. The values given are valid under the specified measuring conditions and may vary due to conditions of installation. For deviations from the standard configuration, the parameters have to be checked on the installed unit.

## Measured values

	Wired	U	f	n	P <sub>e</sub>	I	LpA <sub>in</sub>	LwA <sub>in</sub>	LwA <sub>out</sub>	qv	p <sub>fs</sub>
		V	Hz	min <sup>-1</sup>	W	A	dB(A)	dB(A)	dB(A)	m <sup>3</sup> /h	Pa
1	Δ	480	60	820	1067	2.29	62	69	69	21490	0
2	Δ	480	60	815	1139	2.36	62	68	68	20250	20
3	Δ	480	60	810	1195	2.42	62	69	68	18930	40
4	Δ	480	60	800	1270	2.52	63	69	68	17200	65
5	Y	480	60	640	688	1.22	57	63	62	16620	0
6	Y	480	60	615	709	1.26	56	62	61	15330	12
7	Y	480	60	600	728	1.29	55	62	61	14040	22
8	Y	480	60	575	740	1.33	55	62	61	12460	33

Wired = Wiring · U = Power supply · f = Frequency · n = Speed · P<sub>e</sub> = Power consumption · I = Current draw · LpA<sub>in</sub> = Sound pressure level intake side · LwA<sub>in</sub> = Sound power level intake side  
LwA<sub>out</sub> = Sound power level outlet side · qv = Air flow · p<sub>fs</sub> = Pressure increase

