

S8D630-AN01-01 ebmpapst Datasheet FansCo
 sales@fansco.com
 www.fansco.com

Nominal data

Type	S8D630-AN01-01				
Motor	M8D110-GF				
Phase		3~	3~	3~	3~
Nominal voltage	VAC	400	400	480	480
Connection		Δ	Y	Δ	Y
Frequency	Hz	50	50	60	60
Type of data definition		ml	ml	ml	ml
Valid for approval / standard		CE	CE	CE	CE
Speed	min ⁻¹	660	520	780	560
Power input	W	330	190	490	270
Current draw	A	0.83	0.39	0.94	0.45
Max. back pressure	Pa	60	36	80	37
Min. ambient temperature	°C	-40	-40	-40	-40
Max. ambient temperature	°C	65	65	55	55
Starting current	A	1.85	0.62		

ml = Max. load · me = Max. efficiency · fa = Running at free air · cs = Customer specs · cu = Customer unit
 Subject to alterations

Data according to ErP directive

Installation category	A
Efficiency category	Static
Variable speed drive	No
Specific ratio*	1.00

* Specific ratio = $1 + p_{fs} / 100\,000\text{ Pa}$

		Actual	Request 2013	Request 2015
Overall efficiency η_{es}	%	26.5	26.5	30.5
Efficiency grade N		36	36	40
Power input P_e	kW	0.32		
Air flow q_v	m ³ /h	5255		
Pressure increase p_{fs}	Pa	58		
Speed n	min ⁻¹	670		

Data definition with optimum efficiency. LU-105817
 The ErP data is determined using a motor-impeller combination in a standardised measurement configuration.



Technical features

Mass	14.1 kg
Size	630 mm
Surface of rotor	Coated in black
Material of terminal box	PP plastic
Material of blades	Press-fitted sheet steel blank, sprayed with PP plastic
Material of guard grille	Steel, coated in black plastic (RAL9005)
Number of blades	5
Direction of rotation	"V"
Type of protection	IP 54
Insulation class	"F"
Humidity class	F4-1
Max. permissible ambient motor temp. (transp./ storage)	+ 80 °C
Min. permissible ambient motor temp. (transp./storage)	- 40 °C
Mounting position	Shaft horizontal or rotor on bottom; rotor on top on request
Condensate discharge holes	Rotor-side
Operation mode	S1
Motor bearing	Ball bearing
Touch current acc. IEC 60990 (measuring network Fig. 4, TN system)	<= 3.5 mA
Electrical leads	Via terminal box
Motor protection	Thermal overload protector (TOP) brought out
Cable exit	Axial
Protection class	I (if protective earth is connected by customer)
Product conforming to standard	EN 61800-5-1; CE
Approval	EAC; VDE

AC axial fan - HyBlade®

sickled blades (S series)

with guard grille for short nozzle

Product drawing

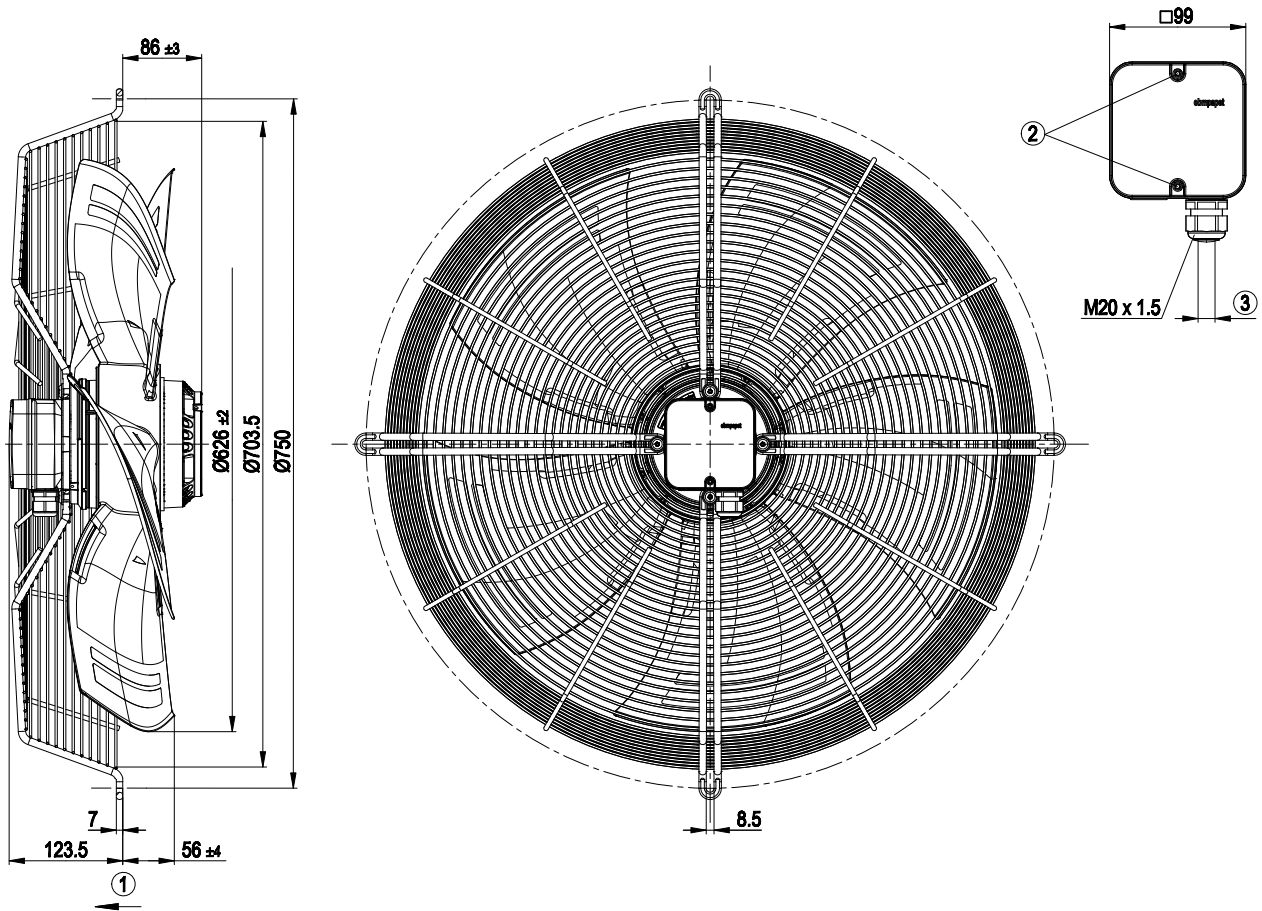

1	Direction of air flow "V"
2	Tightening torque 1.5±0.2 Nm
3	Cable diameter: min. 6 mm, max. 12 mm; tightening torque: 2±0.3 Nm



AC axial fan - HyBlade®

sickled blades (S series)

with guard grille for short nozzle

Connection screen

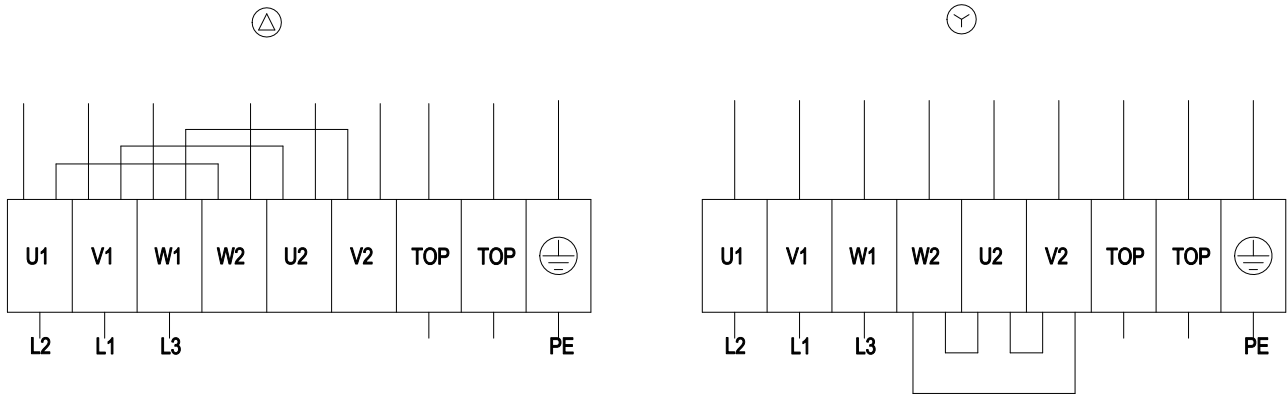

Δ	Delta connection	Y	Star connection	L1	= V1 = blue
L2	= U1 = black	L3	= W1 = brown	W2	yellow
U2	green	V2	white	TOP	2 x grey
PE	green/yellow				



Charts: Air flow 50 Hz

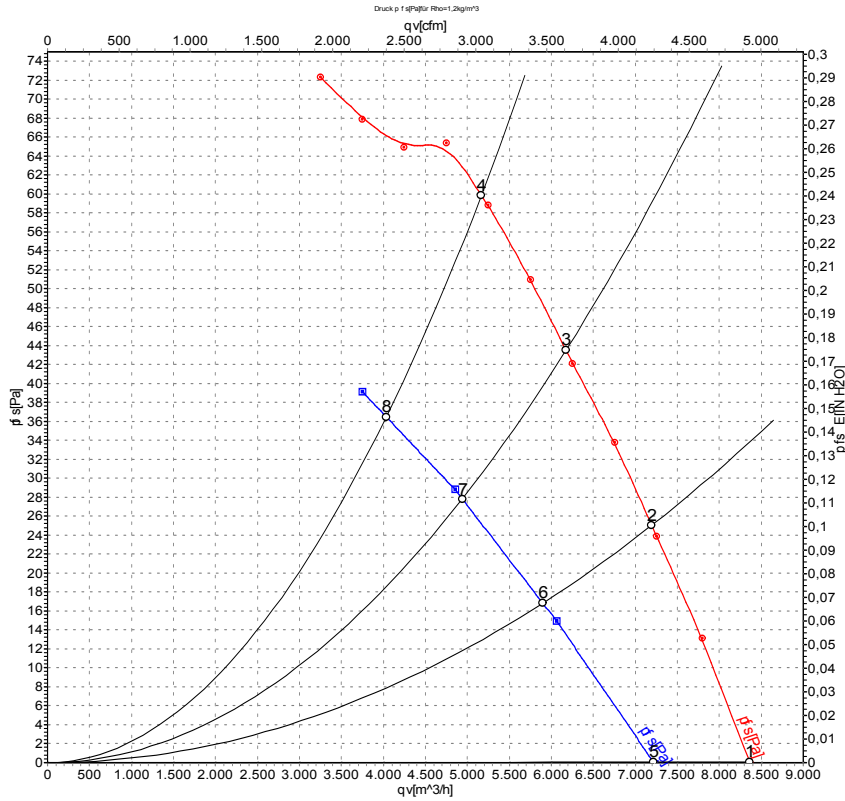

Air performance measured as per ISO 5801 Installation category A. For detailed information on the measuring set-up, please contact ebm-papst. Suction-side noise levels: LwA measured as per ISO 13347 / LpA measured with 1m distance to fan axis. The values given are valid under the measuring conditions mentioned above and may vary according to the actual installation situation. With any deviation from the standard set-up, the specific values have to be checked and reviewed with the unit installed.

Measured values

	Conn.	U	f	n	P _e	I	LpA _{in}	LwA _{in}	LwA _{out}	qv	p _{fs}
		V	Hz	min ⁻¹	W	A	dB(A)	dB(A)	dB(A)	m³/h	Pa
1	Δ	400	50	700	248	0.79	58	63	62	8360	0
2	Δ	400	50	685	285	0.81	54	60	60	7195	25
3	Δ	400	50	675	309	0.82	54	60	59	6175	44
4	Δ	400	50	660	330	0.83	54	61	60	5165	60
5	Y	400	50	600	157	0.33	53	59	58	7215	0
6	Y	400	50	560	176	0.35	50	56	55	5900	17
7	Y	400	50	535	186	0.37	49	55	54	4940	28
8	Y	400	50	520	190	0.39	49	55	55	4035	36

Conn. = Connection · U = Supply voltage · f = Frequency · n = Speed · P_e = Power input · I = Current draw · LpA_{in} = Sound pressure level inlet side · LwA_{in} = Sound power level inlet side · LwA_{out} = Sound power level outlet side · qv = Air flow · p_{fs} = Pressure increase



Charts: Air flow 60 Hz

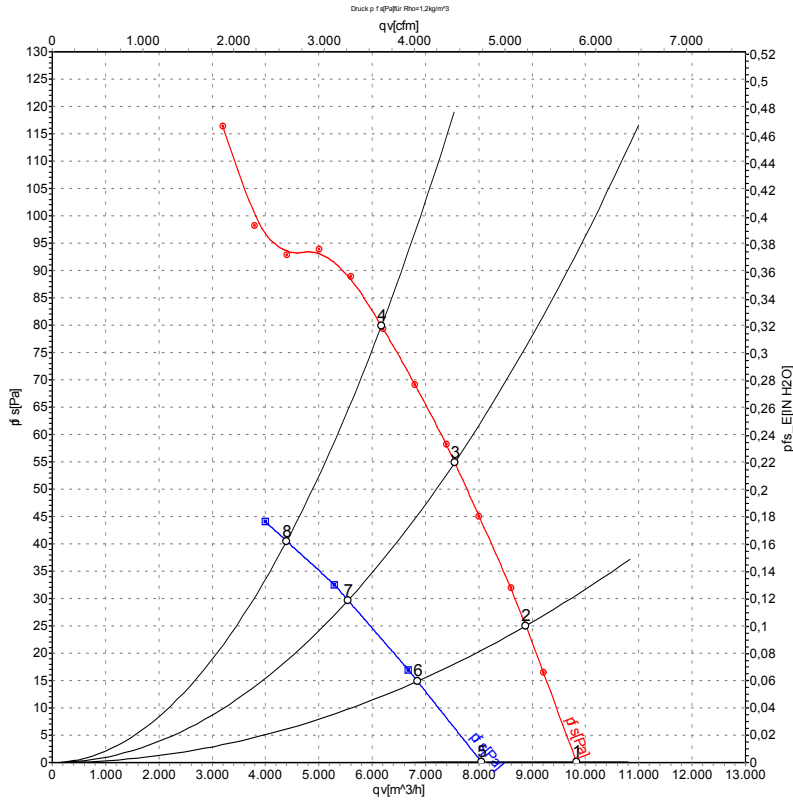

Air performance measured as per ISO 5801 Installation category A. For detailed information on the measuring set-up, please contact ebm-papst. Suction-side noise levels: LwA measured as per ISO 13347 / LpA measured with 1m distance to fan axis. The values given are valid under the measuring conditions mentioned above and may vary according to the actual installation situation. With any deviation from the standard set-up, the specific values have to be checked and reviewed with the unit installed.

Measured values

	Conn.	U	f	n	P _e	I	LpA _{in}	LwA _{in}	LwA _{out}	qv	p _{fs}
		V	Hz	min ⁻¹	W	A	dB(A)	dB(A)	dB(A)	m ³ /h	Pa
1	Δ	480	60	820	366	0.84	61	67	66	9830	0
2	Δ	480	60	810	406	0.88	59	65	64	8880	25
3	Δ	480	60	790	455	0.91	57	63	63	7545	55
4	Δ	480	60	780	490	0.94	58	64	63	6175	80
5	Y	480	60	665	235	0.40	55	61	60	8050	0
6	Y	480	60	620	251	0.42	52	59	58	6850	15
7	Y	480	60	580	265	0.44	50	57	56	5545	30
8	Y	480	60	560	270	0.45	50	57	56	4395	40

Conn. = Connection · U = Supply voltage · f = Frequency · n = Speed · P_e = Power input · I = Current draw · LpA_{in} = Sound pressure level inlet side · LwA_{in} = Sound power level inlet side · LwA_{out} = Sound power level outlet side · qv = Air flow · p_{fs} = Pressure increase

