

S6E630-DN01-35 ebmpapst Datasheet FansCo

sales@fansco.com

www.fansco.com

Nominal data

| | | |
|-----------------------------|-------------------|---------|
| Type | S6E630-DN01-35 | |
| Motor | M6E110-GF | |
| Phase | | 1~ |
| Nominal voltage | VAC | 230 |
| Frequency | Hz | 50 |
| Method of obtaining data | | ml |
| Valid for approval/standard | | CE |
| Speed (rpm) | min ⁻¹ | 860 |
| Power consumption | W | 600 |
| Current draw | A | 2.62 |
| Capacitor | μF | 14 |
| Capacitor voltage | VDB | 400 |
| Capacitor standard | | S0 (CE) |
| Max. back pressure | Pa | 100 |
| Max. back pressure | in. wg | 0.4 |
| Min. ambient temperature | °C | -25 |
| Max. ambient temperature | °C | 55 |
| Starting current | A | 4.8 |

ml = Max. load · me = Max. efficiency · fa = Free air · cs = Customer specification · ce = Customer equipment
Subject to change

Data according to Commission Regulation (EU) 327/2011

| | | Actual | Req. 2015 | | | |
|-----------------------------------|---|--------|-----------|-------------------------------|-------------------|------|
| 01 Overall efficiency η_{es} | % | 32.2 | 32.2 | 09 Power consumption P_e | kW | 0.59 |
| 02 Measurement category | | A | | 09 Air flow q_v | m ³ /h | 6725 |
| 03 Efficiency category | | Static | | 09 Pressure increase p_{fs} | Pa | 98 |
| 04 Efficiency grade N | | 40 | 40 | 10 Speed (rpm) n | min ⁻¹ | 865 |
| 05 Variable speed drive | | No | | 11 Specific ratio* | | 1.00 |

Data obtained at optimum efficiency level.

The ErP data is determined using a motor-impeller combination in a standardized measurement setup.

* Specific ratio = $1 + p_g / 100\,000\text{ Pa}$

LU-105789



AC axial fan - HyBlade

sickle-shaped blades (S series)
with support ring, for barn ventilation

Technical description

| | |
|---|--|
| Weight | 11.8 kg |
| Fan size | 630 mm |
| Rotor surface | Painted black |
| Terminal box material | PP plastic |
| Blade material | Press-fitted, painted sheet steel blank, sprayed with PP plastic |
| Support ring material | Steel, coated with black plastic (RAL 9005) |
| Number of blades | 5 |
| Airflow direction | "A" |
| Direction of rotation | Clockwise, viewed toward rotor |
| Degree of protection | IP54 |
| Insulation class | "F" |
| Moisture (F) / Environmental (H) protection class | H2+ |
| Ambient temperature note | Occasional start-up between -40°C and -25°C is permissible. For continuous operation at temperatures below -25°C (e.g. refrigeration applications) we recommend our fan design with special low-temperature bearings. |
| Max. permitted ambient temp. for motor (transport/storage) | + 80 °C |
| Min. permitted ambient temp. for motor (transport/storage) | - 40 °C |
| Installation position | Shaft horizontal or rotor on top; rotor on bottom on request |
| Condensation drainage holes | On stator side |
| Mode | S1 |
| Motor bearing | Ball bearing |
| Touch current according to IEC 60990 (measuring circuit Fig. 4, TN system) | <= 3.5 mA |
| Electrical hookup | Via terminal box, capacitor integrated and connected |
| Motor protection | Thermal overload protector (TOP) with basic insulation |
| Protection class | I (with customer connection of protective earth) |
| Motor capacitor according to EN 60252-1 in safety protection class | S0 |
| Conformity with standards | EN 61800-5-1; EN 60034-1 (2010); CE |
| Approval | VDE; EAC |



AC axial fan - HyBlade

sickle-shaped blades (S series)
with support ring, for barn ventilation

Product drawing

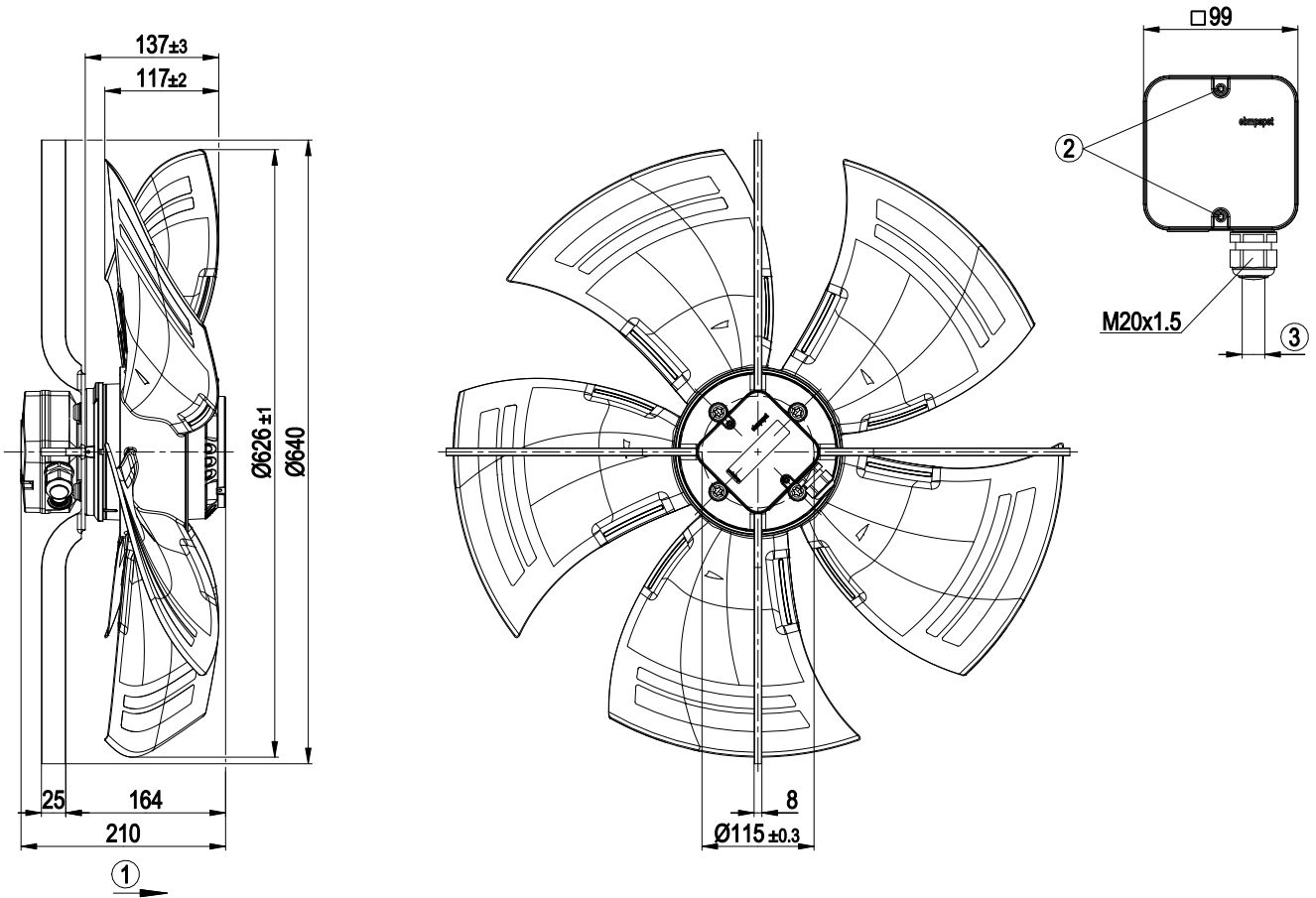

| | |
|---|--|
| 1 | Direction of air flow "A" |
| 2 | Tightening torque 1.5 ± 0.2 Nm |
| 3 | Cable diameter min. 6 mm, max. 12 mm, tightening torque 2 ± 0.3 Nm |



AC axial fan - HyBlade

sickle-shaped blades (S series)
with support ring, for barn ventilation

Connection diagram

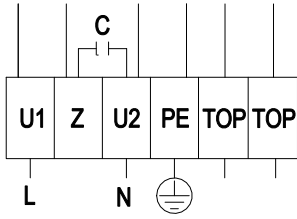

| | | | | | |
|----|--------------|-----|-------|---|--------------|
| L | = U1 = blue | Z | brown | N | = U2 = black |
| PE | green/yellow | TOP | gray | | |



AC axial fan - HyBlade

sickle-shaped blades (S series)
with support ring, for barn ventilation

Curves: Air performance 50 Hz

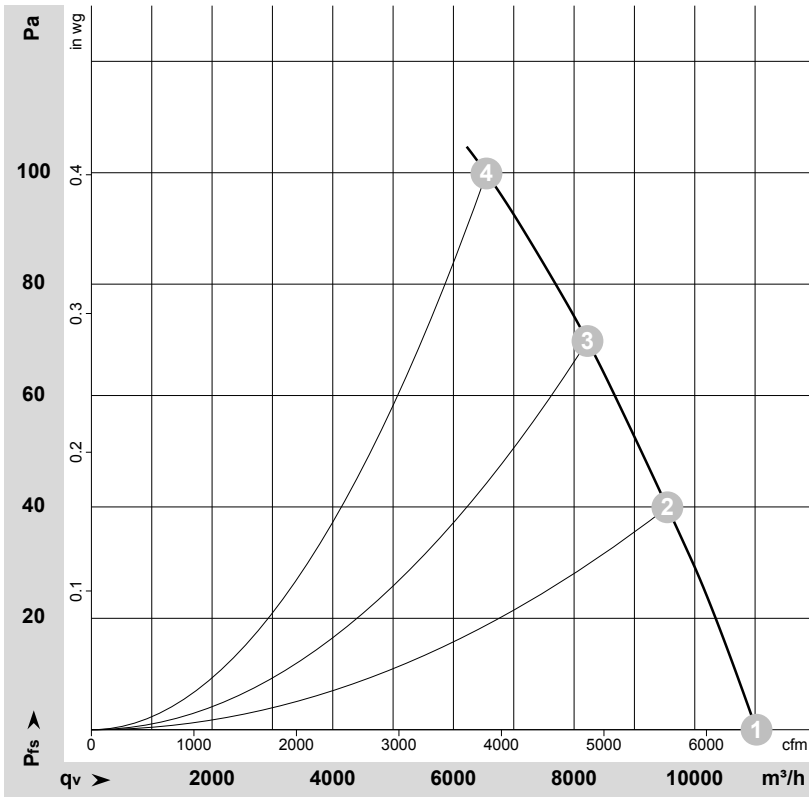

$\rho = 1.177 \text{ kg/m}^3 \pm 2 \%$

Measurement: LU-105789-1

Air performance measured according to ISO 5801 installation category A. For detailed information on the measurement setup, contact ebmpapst. Intake sound level: Sound power level according to ISO 13347 / sound pressure level measured at 1 m distance from fan axis. The values given are valid under the specified measuring conditions and may vary due to conditions of installation. For deviations from the standard configuration, the parameters have to be checked on the installed unit.

Measured values

| | U | f | n | Pe | I | LpA _{in} | LwA _{in} | LwA _{out} | qv | Pfs | qv | Pfs |
|---|-----|----|-------------------|-----|------|-------------------|-------------------|--------------------|-------------------|-----|------|--------|
| | V | Hz | min ⁻¹ | W | A | dB(A) | dB(A) | dB(A) | m ³ /h | Pa | cfm | in. wg |
| 1 | 230 | 50 | 925 | 467 | 2.04 | 64 | 70 | 70 | 11025 | 0 | 6490 | 0.00 |
| 2 | 230 | 50 | 905 | 522 | 2.27 | 61 | 67 | 67 | 9545 | 40 | 5620 | 0.16 |
| 3 | 230 | 50 | 885 | 559 | 2.44 | 60 | 66 | 65 | 8220 | 70 | 4840 | 0.28 |
| 4 | 230 | 50 | 860 | 600 | 2.62 | 61 | 68 | 67 | 6550 | 100 | 3855 | 0.40 |

U = Power supply · f = Frequency · n = Speed (rpm) · Pe = Power consumption · I = Current draw · LpA_{in} = Sound pressure level intake side · LwA_{in} = Sound power level intake side
LwA_{out} = Sound power level outlet side · qv = Air flow · Pfs = Pressure increase

