

# AC axial fan - HyBlade

sickle-shaped blades (S series)

with guard grille for full nozzle

S6E630-BN01-05 ebmpapst Datasheet

sales@fansco.com

www.fansco.com

Limited partnership · Headquarters Muldingen

Amtsgericht (court of registration) Stuttgart · HRA 590344

General partner Elektrobau Muldingen GmbH · Headquarters Muldingen

Amtsgericht (court of registration) Stuttgart · HRB 590142

## Nominal data

<b>Type</b>	<b>S6E630-BN01-05</b>	
<b>Motor</b>	<b>M6E110-GF</b>	
Phase		1~
Nominal voltage	VAC	230
Frequency	Hz	50
Method of obtaining data		ml
Valid for approval/standard		CE
Speed (rpm)	min <sup>-1</sup>	860
Power consumption	W	600
Current draw	A	2.62
Capacitor	μF	14
Capacitor voltage	VDB	400
Capacitor standard		S0 (CE)
Max. back pressure	Pa	100
Max. back pressure	in. wg	0.4
Min. ambient temperature	°C	-40
Max. ambient temperature	°C	55
Starting current	A	4.8

ml = Max. load · me = Max. efficiency · fa = Free air · cs = Customer specification · ce = Customer equipment  
Subject to change

## Data according to Commission Regulation (EU) 327/2011 (EN 17166)

		Actual	Req. 2015			
01 Overall efficiency $\eta_{es}$	%	32.7	32.1	09 Power consumption $P_e$	kW	0.55
02 Measurement category		A		09 Air flow $q_v$	m <sup>3</sup> /h	7130
03 Efficiency category		Static		09 Pressure increase $p_{fs}$	Pa	92
04 Efficiency grade N		40.6	40	10 Speed (rpm) n	min <sup>-1</sup>	870
05 Variable speed drive		No		11 Specific ratio*		1.00

Data obtained at optimum efficiency level.

The ErP data is determined using a motor-impeller combination in a standardized measurement setup.

\* Specific ratio =  $1 + p_g / 100\,000\text{ Pa}$

LU-199801



# AC axial fan - HyBlade

sickle-shaped blades (S series)

with guard grille for full nozzle

## Technical description

Weight	17.1 kg
Size	630 mm
Motor size	110
Rotor surface	Painted black
Terminal box material	ABS plastic
Blade material	Press-fitted sheet steel blank, sprayed with PP plastic
Guard grille material	Steel, coated with black plastic (RAL 9005)
Number of blades	5
Blade pitch	-5°
Airflow direction	V
Direction of rotation	Counterclockwise, viewed toward rotor
Degree of protection	IP54
Insulation class	"F"
Moisture (F) / Environmental (H) protection class	H2
Max. permitted ambient temp. for motor (transport/storage)	+ 80 °C
Min. permitted ambient temp. for motor (transport/storage)	- 40 °C
Installation position	Shaft horizontal or rotor on bottom; rotor on top on request
Condensation drainage holes	On rotor side
Mode	S1
Motor bearing	Ball bearing
Touch current according to IEC 60990 (measuring circuit Fig. 4, TN system)	<= 3.5 mA
Electrical hookup	Terminal box; Via terminal box, capacitor integrated and connected
Motor protection	Thermal overload protector (TOP) with basic insulation
With cable	Axial
Protection class	I (with customer connection of protective earth)
Motor capacitor according to EN 60252-1 in safety protection class	S0
Conformity with standards	EN 61800-5-1; CE
Approval	VDE; EAC



# AC axial fan - HyBlade

sickle-shaped blades (S series)

with guard grille for full nozzle

## Product drawing

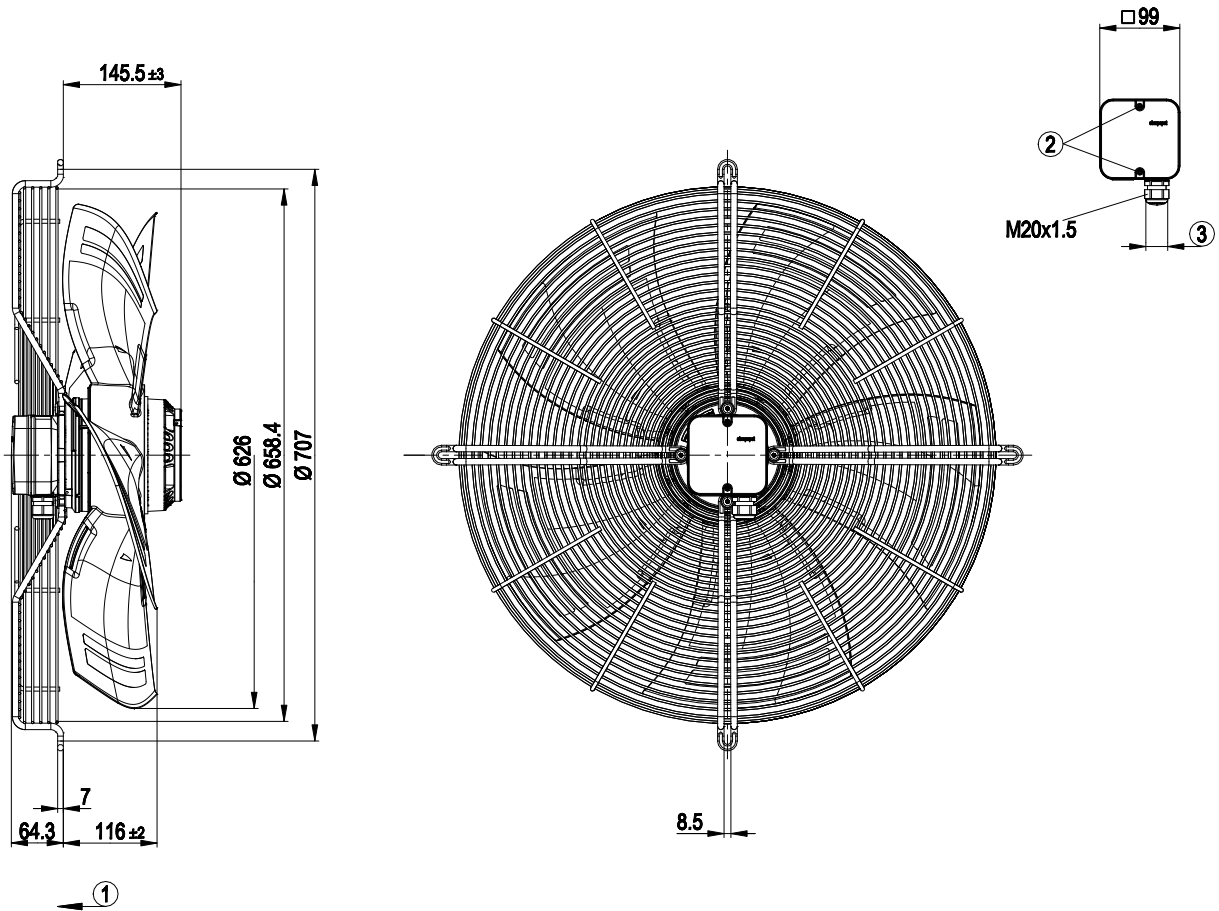

1	Direction of air flow "V"
2	Tightening torque $0.8 \pm 0.15$ Nm
3	Cable diameter: min. 6 mm, max. 12 mm; tightening torque $2 \pm 0.3$ Nm



# AC axial fan - HyBlade

sickle-shaped blades (S series)  
with guard grille for full nozzle

## Connection diagram



L	= U1 = blue	Z	brown	N	= U2 = black
PE	green/yellow	TOP	gray		



# AC axial fan - HyBlade

sickle-shaped blades (S series)

with guard grille for full nozzle

## Curves: Air performance 50 Hz

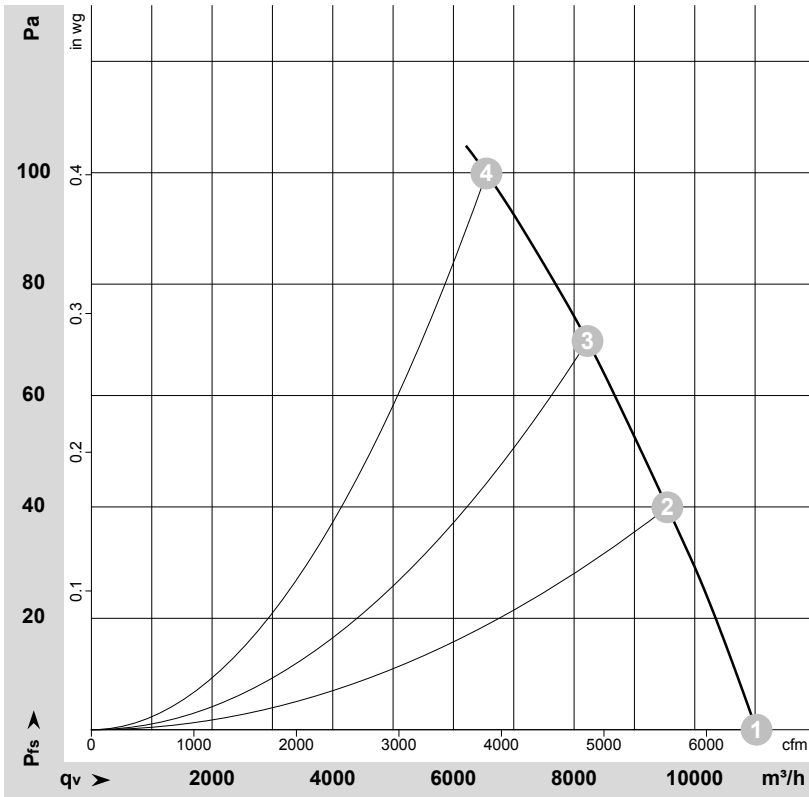

$\rho = 1.177 \text{ kg/m}^3 \pm 2 \%$

Measurement: LU-105789-1

Air performance measured according to ISO 5801 installation category A. For detailed information on the measurement setup, contact ebmpapst. Intake sound level: Sound power level according to ISO 13347 / sound pressure level measured at 1 m distance from fan axis. The values given are valid under the specified measuring conditions and may vary due to conditions of installation. For deviations from the standard configuration, the parameters have to be checked on the installed unit.

## Measured values

	U	f	n	P <sub>e</sub>	I	LpA <sub>in</sub>	LwA <sub>in</sub>	LwA <sub>out</sub>	q <sub>v</sub>	P <sub>fs</sub>	q <sub>v</sub>	P <sub>fs</sub>
	V	Hz	min <sup>-1</sup>	W	A	dB(A)	dB(A)	dB(A)	m <sup>3</sup> /h	Pa	cfm	in. wg
1	230	50	925	467	2.04	64	70	70	11025	0	6490	0.00
2	230	50	905	522	2.27	61	67	67	9545	40	5620	0.16
3	230	50	885	559	2.44	60	66	65	8220	70	4840	0.28
4	230	50	860	600	2.62	61	68	67	6550	100	3855	0.40

U = Voltage · f = Frequency · n = Speed (rpm) · P<sub>e</sub> = Power consumption · I = Current draw · LpA<sub>in</sub> = Sound pressure level intake side · LwA<sub>in</sub> = Sound power level intake side  
 LwA<sub>out</sub> = Sound power level outlet side · q<sub>v</sub> = Air flow · P<sub>fs</sub> = Pressure increase

