

S6E500-AJ03-01 ebmpapst Datasheet

sales@fansco.com

www.fansco.com

Nominal data

Type	S6E500-AJ03-01		
Motor	M6E110-EF		
Phase		1~	1~
Nominal voltage	VAC	230	230
Frequency	Hz	50	60
Type of data definition		ml	ml
Valid for approval / standard		CE	CE
Speed	min ⁻¹	915	1015
Power input	W	270	390
Current draw	A	1.18	1.72
Motor capacitor	µF	8	8
Capacitor voltage	VDB	400	400
Capacitor standard		P0 (CE)	P0 (CE)
Max. back pressure	Pa	70	90
Min. ambient temperature	°C	-40	-40
Max. ambient temperature	°C	65	65
Starting current	A	2.3	

ml = Max. load · me = Max. efficiency · fa = Running at free air · cs = Customer specs · cu = Customer unit
Subject to alterations

Data according to ErP directive

		Actual	Request 2013	Request 2015
Installation category	A			
Efficiency category	Static			
Variable speed drive	No			
Specific ratio*	1.00			
Overall efficiency η_{es}	%	26.6	26	30
Efficiency grade N		36.6	36	40
Power input P_e	kW	0.26		
Air flow q_v	m ³ /h	3805		
Pressure increase p_{fs}	Pa	67		
Speed n	min ⁻¹	915		

Data definition with optimum efficiency. LU-105735
The ErP data is determined using a motor-impeller combination in a standardised measurement configuration.



AC axial fan - HyBlade®

sickled blades (S series)

with guard grille for short nozzle

Technical features

Mass	10.5 kg
Size	500 mm
Surface of rotor	Coated in black
Material of terminal box	PC/ABS plastic, black
Material of blades	Press-fitted sheet steel blank, sprayed with PP plastic
Material of guard grille	Steel, phosphated and coated in black plastic
Number of blades	5
Direction of air flow	"V"
Direction of rotation	Counter-clockwise, seen on rotor
Type of protection	IP 54
Insulation class	"F"
Humidity class	F4-1
Max. permissible ambient motor temp. (transp./ storage)	+ 80 °C
Min. permissible ambient motor temp. (transp./storage)	- 40 °C
Mounting position	Shaft horizontal or rotor on bottom; rotor on top on request
Condensate discharge holes	Rotor-side
Operation mode	S1
Motor bearing	Ball bearing
Touch current acc. IEC 60990 (measuring network Fig. 4, TN system)	<= 3.5 mA
Electrical leads	Via terminal box, integrated capacitor connected via terminal box
Motor protection	Thermal overload protector (TOP) brought out
Cable exit	Axial
Protection class	I (if protective earth is connected by customer)
Product conforming to standard	EN 61800-5-1; CE
Approval	CCC; EAC; UL 1004-1; VDE; CSA C22.2 Nr.100



AC axial fan - HyBlade®

sickled blades (S series)

with guard grille for short nozzle

Product drawing

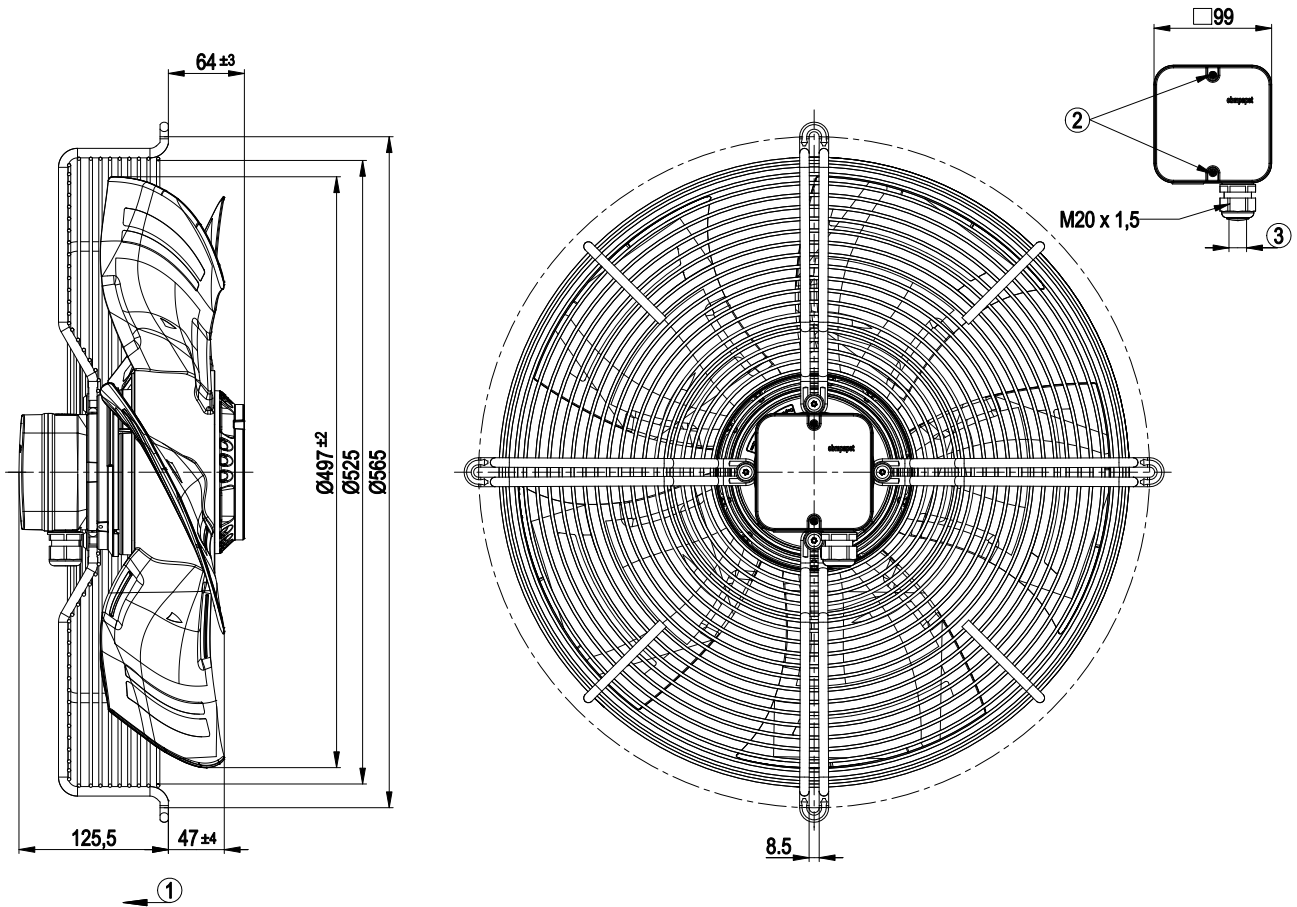

1	Direction of air flow "V"
2	Tightening torque 0.8±0.15 Nm
3	Cable diameter: min. 6 mm, max. 12 mm; tightening torque: 2±0.3 Nm



AC axial fan - HyBlade®

sickled blades (S series)
with guard grille for short nozzle

Connection screen

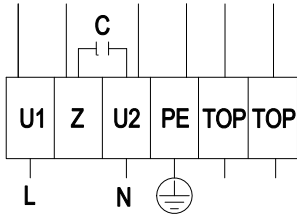

L	= U1 = blue	Z	brown	N	= U2 = black
PE	green / yellow	TOP	grey		



Charts: Air flow 50 Hz

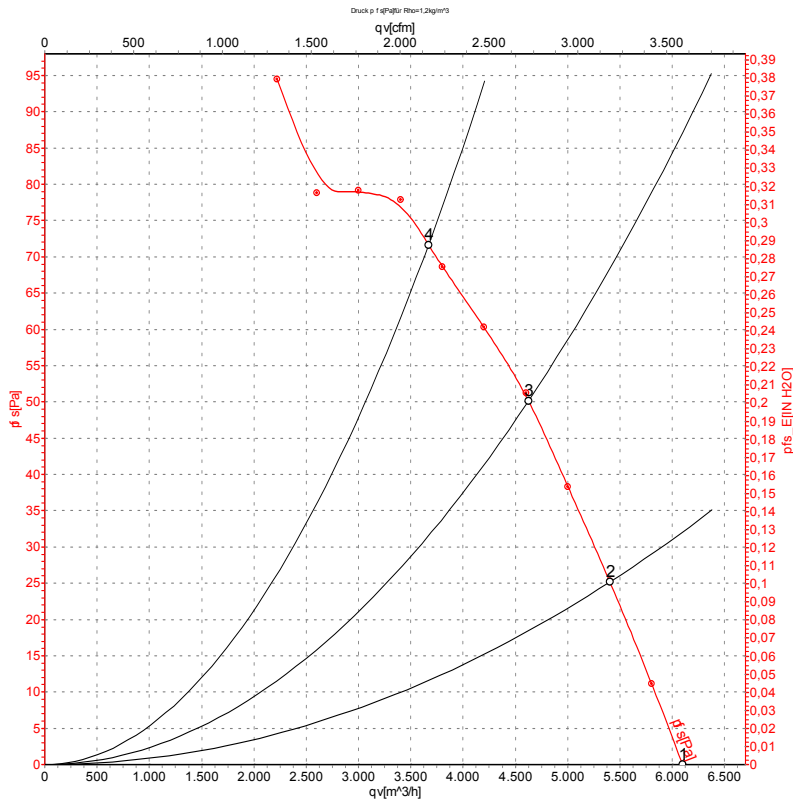

Air performance measured as per ISO 5801 Installation category A. For detailed information on the measuring set-up, please contact ebmpapst. Suction-side noise levels: LwA measured as per ISO 13347 / LpA measured with 1m distance to fan axis. The values given are valid under the measuring conditions mentioned above and may vary according to the actual installation situation. With any deviation from the standard set-up, the specific values have to be checked and reviewed with the unit installed.

Measured values

	U	f	n	P _e	I	LpA _{in}	LwA _{in}	LwA _{out}	qv	p _{fs}
	V	Hz	min ⁻¹	W	A	dB(A)	dB(A)	dB(A)	m ³ /h	Pa
1	230	50	945	220	0.97	61	67	67	6100	0
2	230	50	935	235	1.03	58	64	65	5405	25
3	230	50	925	251	1.10	56	62	63	4625	50
4	230	50	915	270	1.18	56	63	63	3670	70

U = Supply voltage · f = Frequency · n = Speed · P_e = Power input · I = Current draw · LpA_{in} = Sound pressure level inlet side · LwA_{in} = Sound power level inlet side · LwA_{out} = Sound power level outlet side
 qv = Air flow · p_{fs} = Pressure increase



Charts: Air flow 60 Hz

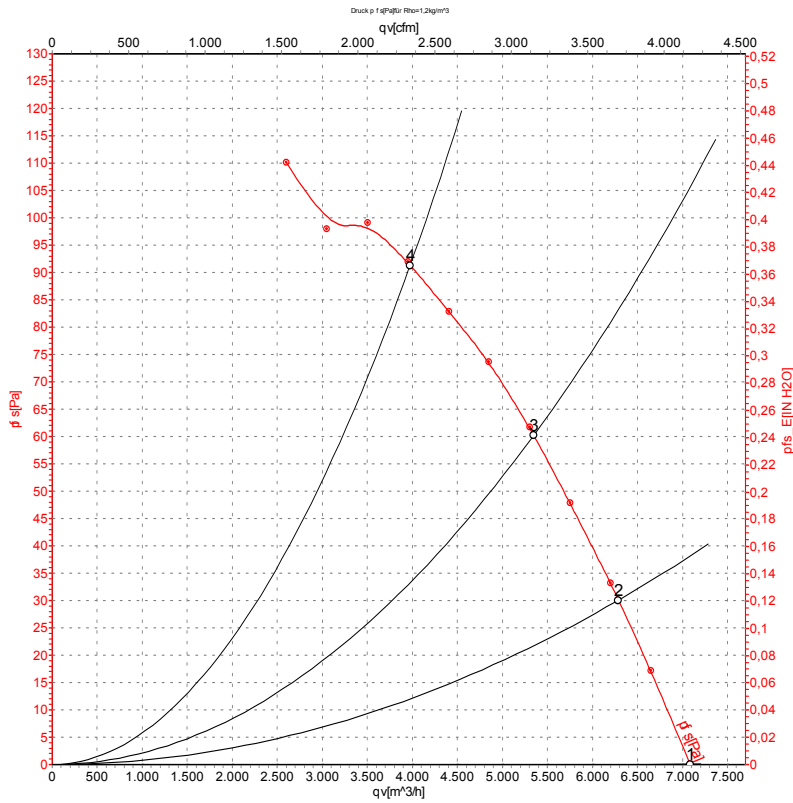

Air performance measured as per ISO 5801 Installation category A. For detailed information on the measuring set-up, please contact ebm-papst. Suction-side noise levels: LwA measured as per ISO 13347 / LpA measured with 1m distance to fan axis. The values given are valid under the measuring conditions mentioned above and may vary according to the actual installation situation. With any deviation from the standard set-up, the specific values have to be checked and reviewed with the unit installed.

Measured values

	U	f	n	Pe	I	LpA _{in}	LwA _{in}	LwA _{out}	qv	ps
	V	Hz	min ⁻¹	W	A	dB(A)	dB(A)	dB(A)	m ³ /h	Pa
1	230	60	1095	340	1.53	63	70	70	7085	0
2	230	60	1075	360	1.59	60	67	67	6290	30
3	230	60	1050	375	1.65	58	65	65	5345	60
4	230	60	1015	390	1.72	58	65	65	3975	90

U = Supply voltage · f = Frequency · n = Speed · Pe = Power input · I = Current draw · LpA_{in} = Sound pressure level inlet side · LwA_{in} = Sound power level inlet side · LwA_{out} = Sound power level outlet side
 qv = Air flow · ps = Pressure increase

