

# AC axial fan

sickled blades (S series), single inlet  
with guard grille for short nozzle

## Nominal data

<b>Type</b>	<b>S6E400-AN24-46</b>		
<b>Motor</b>	<b>M6E074-DF</b>		
Phase		1~	1~
Nominal voltage	VAC	230	230
Frequency	Hz	50	60
Type of data definition		ml	ml
Valid for approval / standard		CE	CE
Speed	min <sup>-1</sup>	870	870
Power input	W	120	150
Current draw	A	0.53	0.67
Motor capacitor	µF	3	3
Capacitor voltage	VDB	400	400
Capacitor standard		P0 (CE)	P0 (CE)
Max. back pressure	Pa	40	40
Min. ambient temperature	°C	-25	-25
Max. ambient temperature	°C	60	45
Starting current	A	0.7	0.69

ml = Max. load · me = Max. efficiency · fa = Running at free air · cs = Customer specs · cu = Customer unit  
Subject to alterations



S6E400-AN24-46

# AC axial fan

sickled blades (S series), single inlet  
with guard grille for short nozzle

## Technical features

Mass	5.4 kg
Size	400 mm
Surface of rotor	Coated in black
Material of blades	Press-fitted sheet steel blank, sprayed with PP plastic
Material of guard grille	Steel, coated in black plastic (RAL9005)
Number of blades	5
Direction of rotation	"A"
Type of protection	IP 44; Depending on installation and position as per EN 60034-5
Insulation class	"F"
Humidity class	F2-2
Max. permissible ambient motor temp. (transp./ storage)	+ 80 °C
Min. permissible ambient motor temp. (transp./storage)	- 40 °C
Mounting position	Shaft horizontal or rotor on bottom; rotor on top on request
Condensate discharge holes	Rotor-side
Operation mode	S1
Motor bearing	Ball bearing
Touch current acc. IEC 60990 (measuring network Fig. 4, TN system)	< 0.75 mA
Electrical leads	Via terminal box, integrated capacitor connected via terminal box
Motor protection	Thermal overload protector (TOP) wired internally
Cable exit	Variable
Protection class	I (if protective earth is connected by customer)
Product conforming to standard	EN 60335-1



S6E400-AN24-46

# AC axial fan

sickled blades (S series), single inlet  
with guard grille for short nozzle

## Product drawing

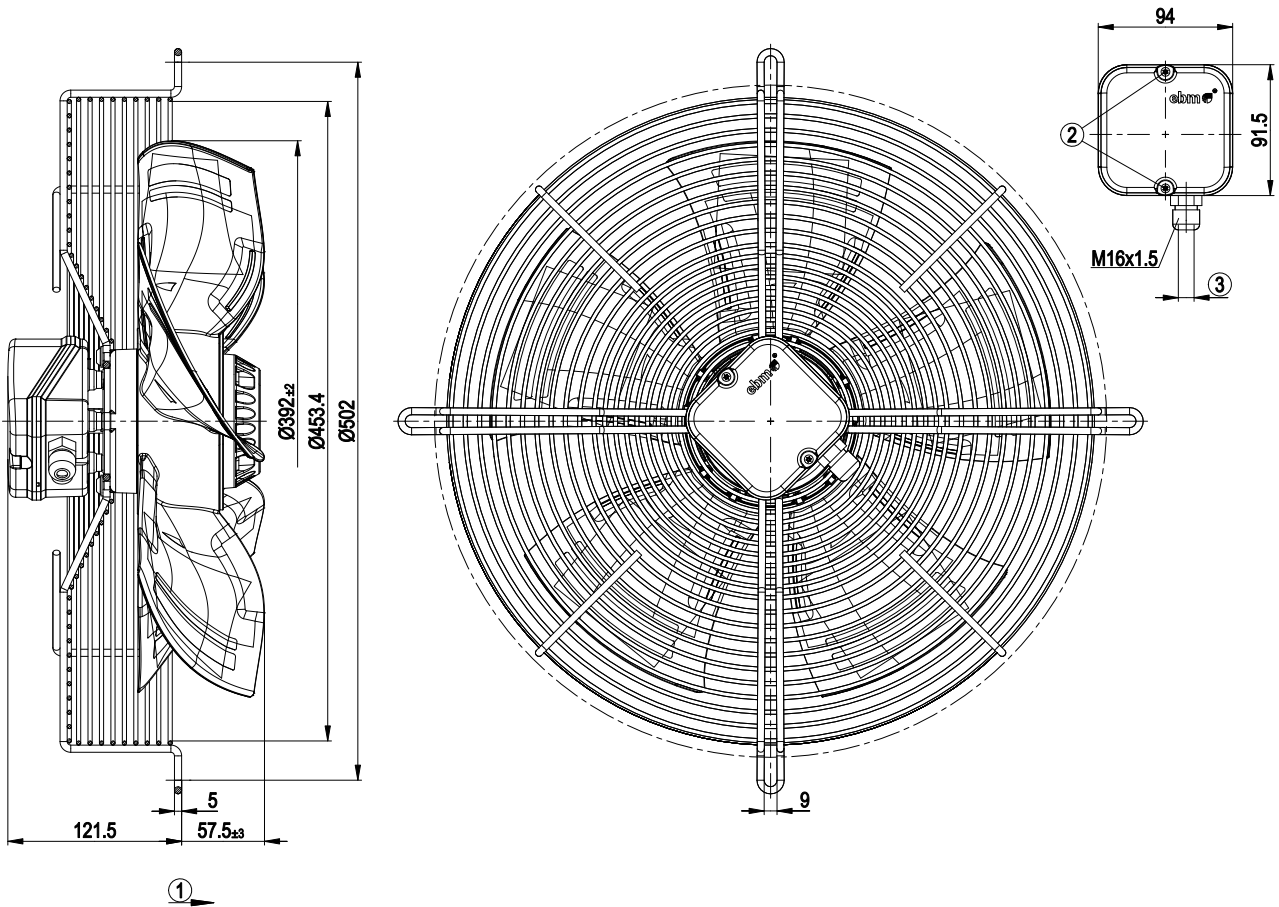

1	Direction of air flow "A"
2	Tightening torque $0.5 \pm 0.1$ Nm
3	Cable diameter: max. 7.5 mm, tightening torque $1.3 \pm 0.2$ Nm

## Connection screen

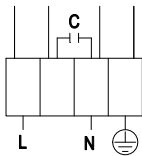

L	= U1 = blue	Z	brown	N	= U2 = black
PE	green/yellow				



# AC axial fan

sickled blades (S series), single inlet  
with guard grille for short nozzle

## Charts: Air flow 50 Hz

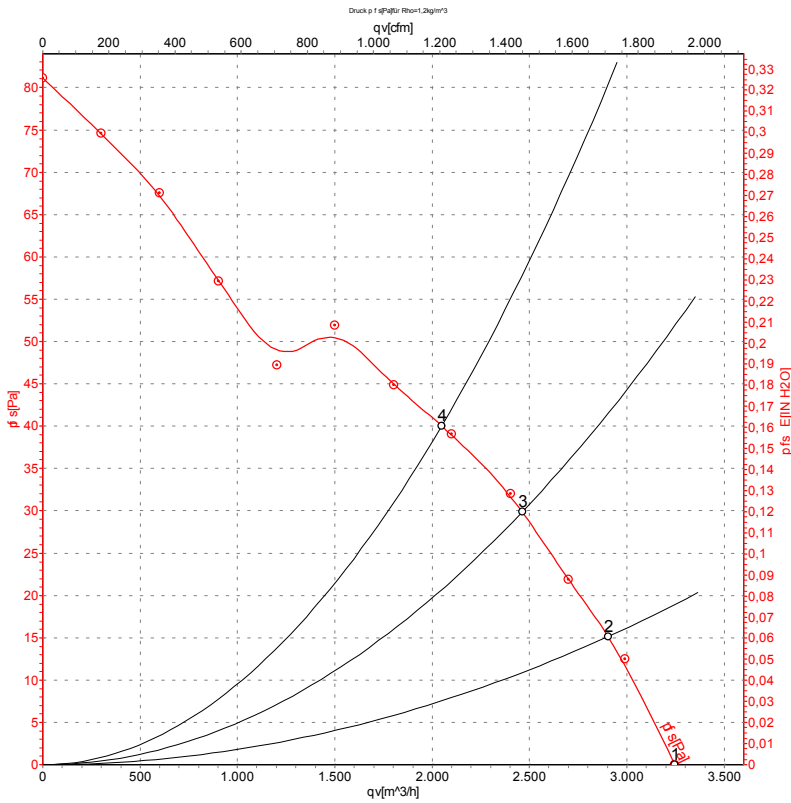

Measurement: LU-126091

Air performance measured as per ISO 5801 Installation category A. For detailed information on the measuring set-up, please contact ebm-papst. Suction-side noise levels: LwA measured as per ISO 13347 / LpA measured with 1m distance to fan axis. The values given are valid under the measuring conditions mentioned above and may vary according to the actual installation situation. With any deviation from the standard set-up, the specific values have to be checked and reviewed with the unit installed.

## Measured values

	U	f	n	Pe	I	LpA <sub>in</sub>	LwA <sub>in</sub>	qv	ps
	V	Hz	min <sup>-1</sup>	W	A	dB(A)	dB(A)	m <sup>3</sup> /h	Pa
1	230	50	900	110	0.49	57	63	3245	0
2	230	50	900	110	0.49	54	61	2905	15
3	230	50	890	114	0.50	51	58	2460	30
4	230	50	870	120	0.53	52	59	2050	40

U = Supply voltage · f = Frequency · n = Speed · Pe = Power input · I = Current draw · LpA<sub>in</sub> = Sound pressure level inlet side · LwA<sub>in</sub> = Sound power level inlet side · qv = Air flow  
ps = Pressure increase



# AC axial fan

sickled blades (S series), single inlet  
with guard grille for short nozzle

## Charts: Air flow 60 Hz

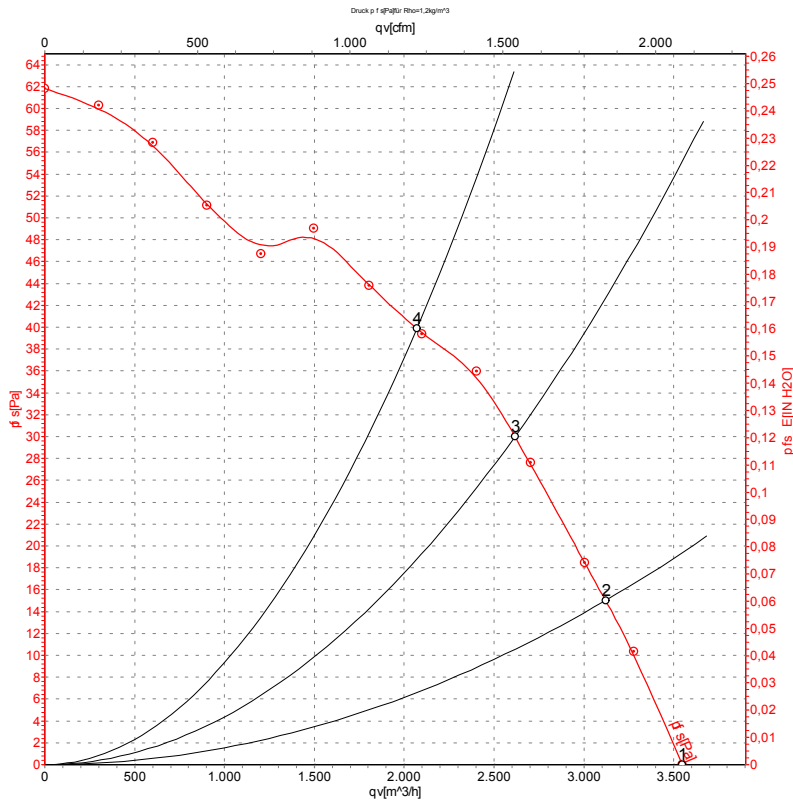

Measurement: LU-126092

Air performance measured as per ISO 5801 Installation category A. For detailed information on the measuring set-up, please contact ebm-papst. Suction-side noise levels: L<sub>wA</sub> measured as per ISO 13347 / L<sub>pA</sub> measured with 1m distance to fan axis. The values given are valid under the measuring conditions mentioned above and may vary according to the actual installation situation. With any deviation from the standard set-up, the specific values have to be checked and reviewed with the unit installed.

## Measured values

	U	f	n	P <sub>e</sub>	I	L <sub>pA<sub>in</sub></sub>	L <sub>wA<sub>in</sub></sub>	qv	p <sub>fs</sub>
	V	Hz	min <sup>-1</sup>	W	A	dB(A)	dB(A)	m <sup>3</sup> /h	Pa
1	230	60	990	145	0.64	59	65	3545	0
2	230	60	955	148	0.64	56	63	3120	15
3	230	60	920	149	0.65	52	59	2615	30
4	230	60	870	150	0.67	52	60	2070	40

U = Supply voltage · f = Frequency · n = Speed · P<sub>e</sub> = Power input · I = Current draw · L<sub>pA<sub>in</sub></sub> = Sound pressure level inlet side · L<sub>wA<sub>in</sub></sub> = Sound power level inlet side · qv = Air flow  
p<sub>fs</sub> = Pressure increase

