

AC axial fan

sickle-shaped blades (S series), single-intake
with support ring

S6E350-DN24-34 ebmpapst Datasheet
sales@fansco.com
www.fansco.com

Limited partnership · Headquarters Muldingen
Amtsgericht (court of registration) Stuttgart · HRA 590344
General partner Elektrobau Muldingen GmbH · Headquarters Muldingen
Amtsgericht (court of registration) Stuttgart · HRB 590142

Nominal data

Type	S6E350-DN24-34		
Motor	M6E074-DF		
Phase		1~	1~
Nominal voltage	VAC	230	230
Frequency	Hz	50	60
Method of obtaining data		ml	ml
Valid for approval/standard		CE	CE
Speed (rpm)	min ⁻¹	910	1020
Power consumption	W	75	95
Current draw	A	0.35	0.42
Capacitor	µF	2	2
Capacitor voltage	VDB	400	400
Capacitor standard		S0 (CE)	S0 (CE)
Max. back pressure	Pa	40	50
Max. back pressure	inH ₂ O	0.16	0.2
Min. ambient temperature	°C	-40	-40
Max. ambient temperature	°C	70	75
Starting current	A	0.56	0.51

ml = Max. load · me = Max. efficiency · fa = Free air · cs = Customer specification · ce = Customer equipment
Subject to change



AC axial fan

sickle-shaped blades (S series), single-intake
with support ring

Technical description

Weight	4.35 kg
Fan size	350 mm
Rotor surface	Painted black
Terminal box material	PC/ABS plastic
Blade material	Press-fitted sheet steel blank, sprayed with PP plastic
Support ring material	Steel, galvanized and coated with white plastic (RAL 9003)
Number of blades	5
Airflow direction	"V"
Direction of rotation	Counterclockwise, viewed toward rotor
Degree of protection	IP44; installation- and position-dependent as per EN 60034-5
Insulation class	"F"
Moisture (F) / Environmental (H) protection class	F2-2
Max. permitted ambient temp. for motor (transport/storage)	+ 80 °C
Min. permitted ambient temp. for motor (transport/storage)	- 40 °C
Installation position	Shaft horizontal or rotor on bottom; rotor on top on request
Condensation drainage holes	On rotor side
Mode	S1
Motor bearing	Ball bearing with low-temperature lubricant
Touch current according to IEC 60990 (measuring circuit Fig. 4, TN system)	< 0.75 mA
Electrical hookup	Via terminal box, capacitor integrated and connected
Motor protection	Thermal overload protector (TOP) internally connected
With cable	Variable
Protection class	I (with customer connection of protective earth)
Motor capacitor according to EN 60252-1 in safety protection class	S0
Conformity with standards	EN 60335-1; CE



AC axial fan

sickle-shaped blades (S series), single-intake
with support ring

Product drawing

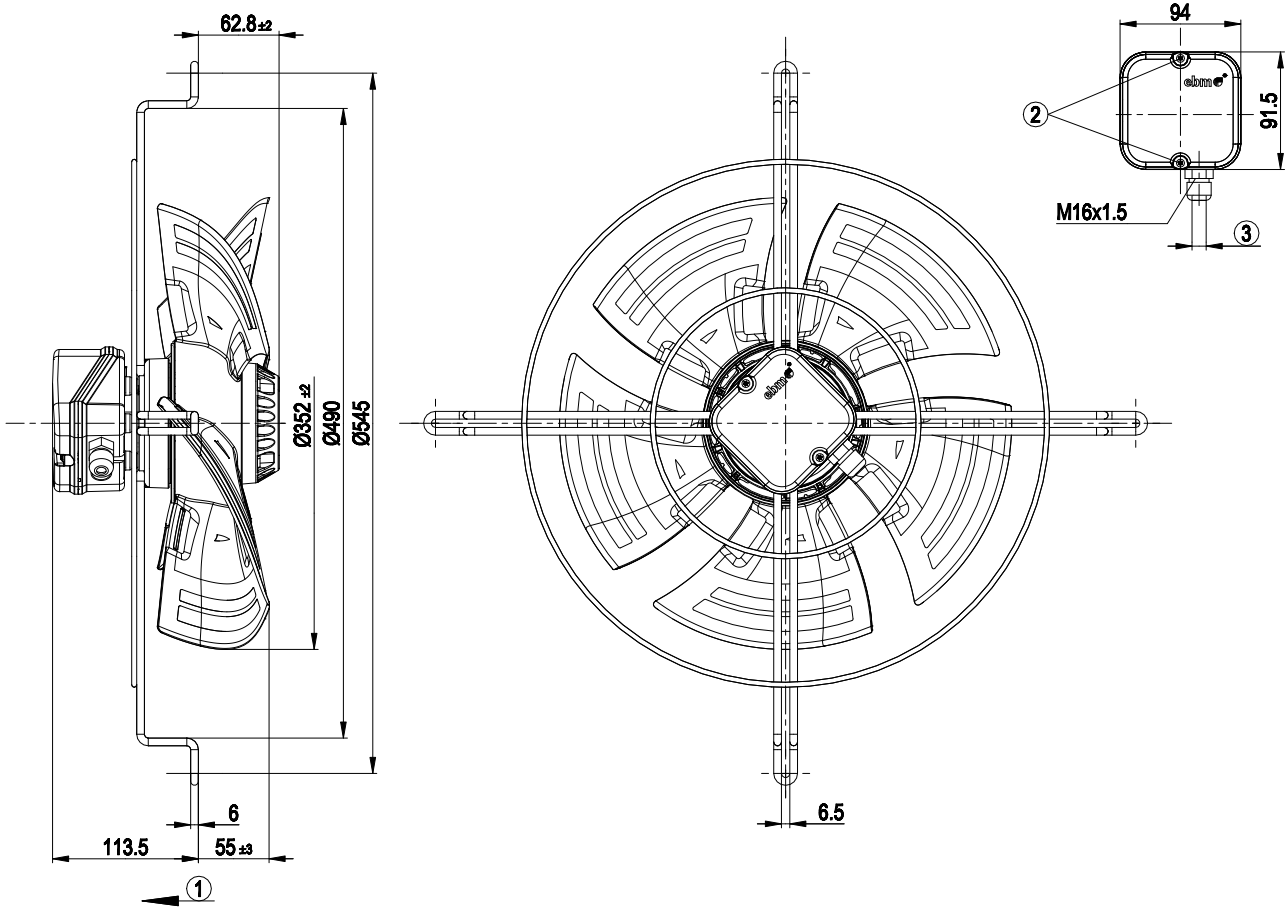

1	Direction of air flow "V"
2	Tightening torque 0.5 ± 0.1 Nm
3	Cable diameter: max. 7.5 mm, tightening torque 1.3±0.2 Nm

Connection diagram



L	= U1 = blue	Z	brown	N	= U2 = black
PE	green/yellow				



AC axial fan

sickle-shaped blades (S series), single-intake
with support ring

Curves: Air performance 50 Hz

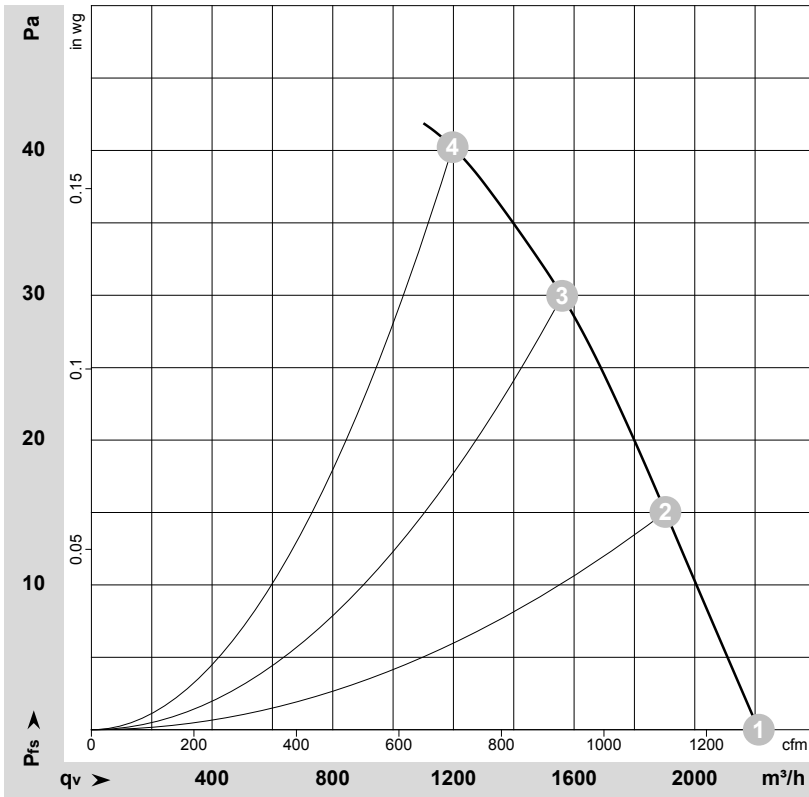

$\rho = 1.15 \text{ kg/m}^3 \pm 2 \%$

Measurement: LU-131056-1

Air performance measured according to ISO 5801 installation category A. For detailed information on the measurement setup, contact ebmpapst. Intake sound level: Sound power level according to ISO 13347 / sound pressure level measured at 1 m distance from fan axis. The values given are valid under the specified measuring conditions and may vary due to conditions of installation. For deviations from the standard configuration, the parameters have to be checked on the installed unit.

Measured values

	U	f	n	P _e	I	LpA _{in}	LwA _{in}	q _v	p _{fs}	q _v	p _{fs}
	V	Hz	min ⁻¹	W	A	dB(A)	dB(A)	m ³ /h	Pa	cfm	inH ₂ O
1	230	50	935	67	0.33	51	59	2210	0	1300	0.00
2	230	50	925	70	0.33	49	57	1905	15	1120	0.06
3	230	50	915	72	0.34	46	54	1560	30	920	0.12
4	230	50	910	75	0.35	45	53	1195	40	705	0.16

U = Power supply · f = Frequency · n = Speed (rpm) · P_e = Power consumption · I = Current draw · LpA_{in} = Sound pressure level intake side · LwA_{in} = Sound power level intake side
q_v = Air flow · p_{fs} = Pressure increase



AC axial fan

sickle-shaped blades (S series), single-intake
with support ring

Curves: Air performance 60 Hz

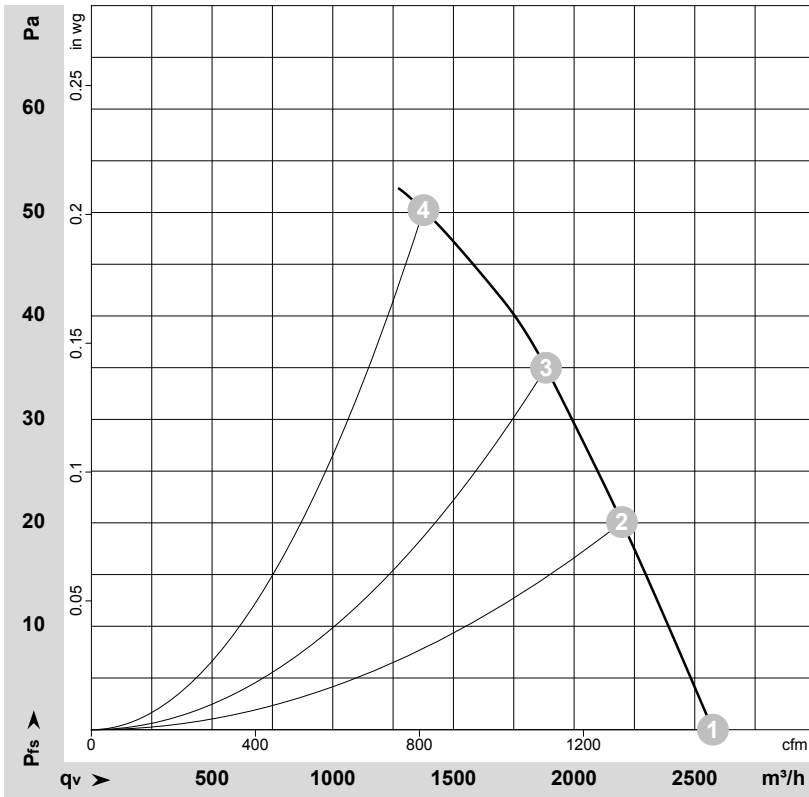

$\rho = 1.15 \text{ kg/m}^3 \pm 2 \%$

Measurement: LU-131059-1

Air performance measured according to ISO 5801 installation category A. For detailed information on the measurement setup, contact ebmpapst. Intake sound level: Sound power level according to ISO 13347 / sound pressure level measured at 1 m distance from fan axis. The values given are valid under the specified measuring conditions and may vary due to conditions of installation. For deviations from the standard configuration, the parameters have to be checked on the installed unit.

Measured values

	U	f	n	P _e	I	LpA _{in}	LwA _{in}	q _v	p _{fs}	q _v	p _{fs}
	V	Hz	min ⁻¹	W	A	dB(A)	dB(A)	m ³ /h	Pa	cfm	inH ₂ O
1	230	60	1095	83	0.36	55	62	2575	0	1515	0.00
2	230	60	1070	87	0.38	53	60	2200	20	1295	0.08
3	230	60	1050	90	0.39	50	57	1885	35	1110	0.14
4	230	60	1020	95	0.42	48	56	1375	50	810	0.20

U = Power supply · f = Frequency · n = Speed (rpm) · P_e = Power consumption · I = Current draw · LpA_{in} = Sound pressure level intake side · LwA_{in} = Sound power level intake side
q_v = Air flow · p_{fs} = Pressure increase

