

# AC axial fan

sickle-shaped blades (S series)

with guard grille for full nozzle

S6E315-BP02-30 ebmpapst Datasheet

sales@fansco.com

www.fansco.com

Limited partnership · Headquarters Mulfingen

Amtsgericht (court of registration) Stuttgart · HRA 590344

General partner Elektrobau Mulfingen GmbH · Headquarters Mulfingen

Amtsgericht (court of registration) Stuttgart · HRB 590142

## Nominal data

Type	S6E315-BP02-30			
Motor	M6E068-DF			
Phase		1~	1~	1~
Nominal voltage	VAC	230	230	277
Frequency	Hz	50	60	60
Method of obtaining data		fa	fa	fa
Valid for approval/standard		CE	CE	UL
Speed (rpm)	min <sup>-1</sup>	950	1120	1140
Power consumption	W	65	68	93
Current draw	A	0.33	0.30	0.37
Capacitor	µF	2	2	2
Capacitor voltage	VDB	400	450	500
Capacitor standard		S0 (CE)	S0 (CE)	UL
Max. back pressure	Pa	70	80	80
Max. back pressure	inH <sub>2</sub> O	0.28	0.32	0.32
Min. ambient temperature	°C	-25	-25	-25
Max. ambient temperature	°C	50	60	60
Starting current	A	0.55	0.5	0.62

ml = Max. load · me = Max. efficiency · fa = Free air · cs = Customer specification · ce = Customer equipment  
Subject to change



# AC axial fan

sickle-shaped blades (S series)  
with guard grille for full nozzle

## Technical description

<b>Weight</b>	3.4 kg
<b>Fan size</b>	315 mm
<b>Rotor surface</b>	Painted black
<b>Blade material</b>	Sheet steel, painted black
<b>Guard grille material</b>	Steel, phosphated and coated with black plastic
<b>Number of blades</b>	5
<b>Airflow direction</b>	"V"
<b>Direction of rotation</b>	Counterclockwise, viewed toward rotor
<b>Degree of protection</b>	IP44; installation- and position-dependent as per EN 60034-5
<b>Insulation class</b>	"B"
<b>Moisture (F) / Environmental (H) protection class</b>	F1-2
<b>Max. permitted ambient temp. for motor (transport/storage)</b>	+ 80 °C
<b>Min. permitted ambient temp. for motor (transport/storage)</b>	- 40 °C
<b>Installation position</b>	Shaft horizontal or rotor on bottom
<b>Condensation drainage holes</b>	On rotor side
<b>Mode</b>	S1
<b>Motor bearing</b>	Ball bearing
<b>Touch current according to IEC 60990 (measuring circuit Fig. 4, TN system)</b>	< 0.75 mA
<b>Motor protection</b>	Thermal overload protector (TOP) internally connected
<b>With cable</b>	Axial
<b>Protection class</b>	I (with customer connection of protective earth)
<b>Conformity with standards</b>	EN 60335-1; CE



# AC axial fan

sickle-shaped blades (S series)  
with guard grille for full nozzle

## Product drawing

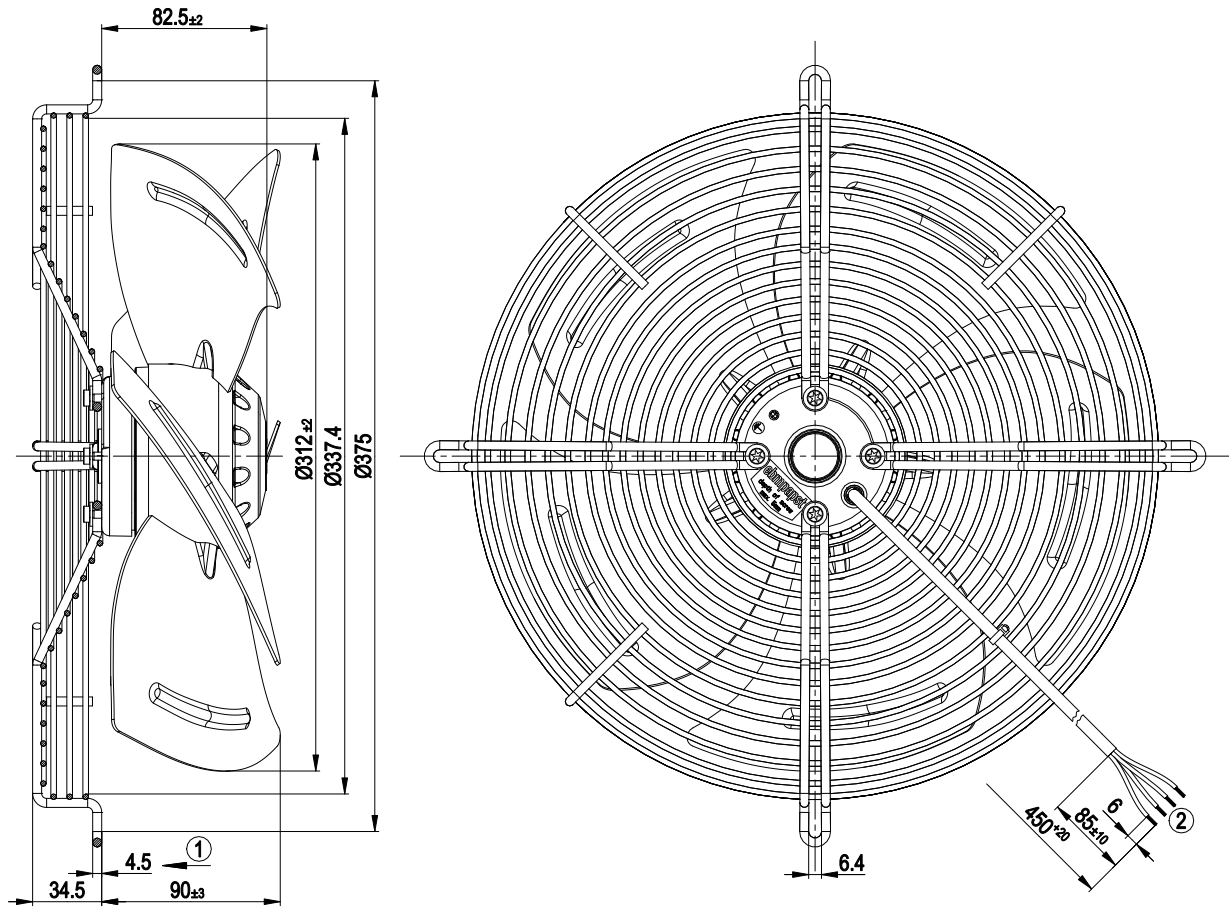

- 1 Direction of air flow "V"
- 2 Cable PVC 4G 0.5 mm<sup>2</sup>, 4x crimped splices

## Connection diagram



U1	blue	Z	brown	U2	black
PE	green/yellow				



# AC axial fan

sickle-shaped blades (S series)  
with guard grille for full nozzle

## Curves: Air performance 50 Hz

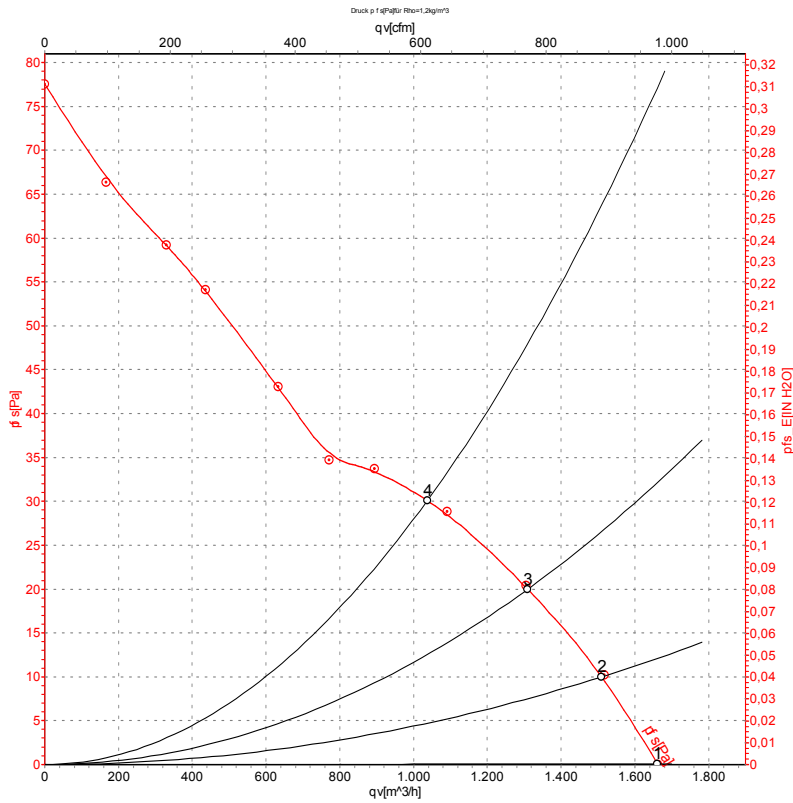

Measurement: LU-32937-1

Air performance measured according to ISO 5801 installation category A. For detailed information on the measurement setup, contact ebm-papst. Intake sound level: Sound power level according to ISO 13347 / sound pressure level measured at 1 m distance from fan axis. The values given are valid under the specified measuring conditions and may vary due to conditions of installation. For deviations from the standard configuration, the parameters have to be checked on the installed unit.

## Measured values

	U	f	n	Pe	I	qv	ps	qv	ps
	V	Hz	min <sup>-1</sup>	W	A	m <sup>3</sup> /h	Pa	cfm	inH2O
1	230	50	950	65	0.33	1660	0	980	0.00
2	230	50	945	65	0.33	1510	10	890	0.04
3	230	50	935	65	0.33	1310	20	770	0.08
4	230	50	925	66	0.33	1035	30	610	0.12

U = Power supply · f = Frequency · n = Speed (rpm) · Pe = Power consumption · I = Current draw · qv = Air flow · ps = Pressure increase



# AC axial fan

sickle-shaped blades (S series)  
with guard grille for full nozzle

## Curves: Air performance 60 Hz

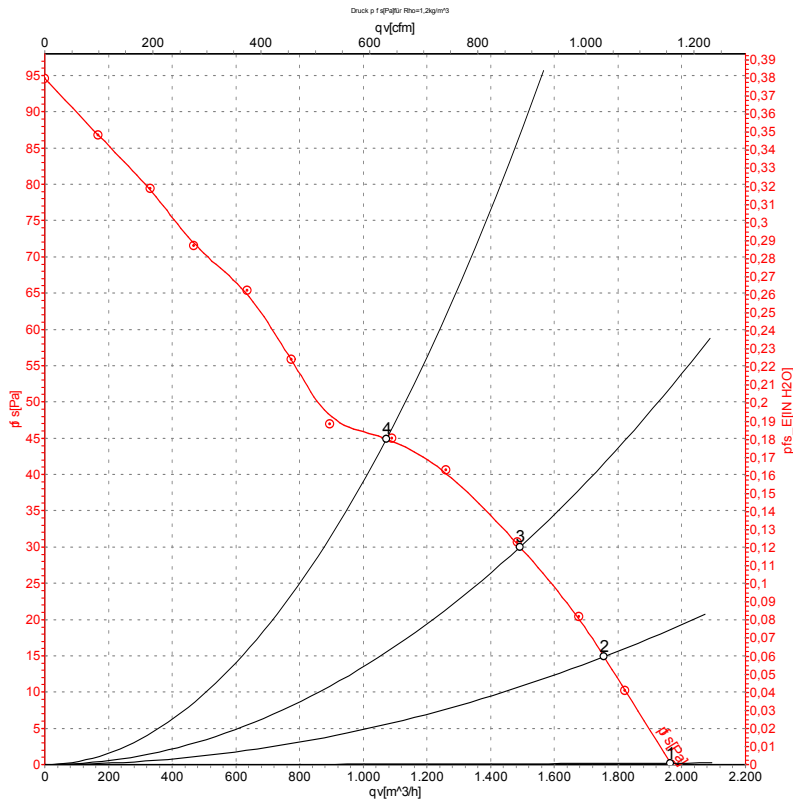

Measurement: LU-32938-1

Air performance measured according to ISO 5801 installation category A. For detailed information on the measurement setup, contact ebm-papst. Intake sound level: Sound power level according to ISO 13347 / sound pressure level measured at 1 m distance from fan axis. The values given are valid under the specified measuring conditions and may vary due to conditions of installation. For deviations from the standard configuration, the parameters have to be checked on the installed unit.

## Measured values

	U	f	n	Pe	I	qv	ps	qv	ps
	V	Hz	min <sup>-1</sup>	W	A	m <sup>3</sup> /h	Pa	cfm	inH2O
1	230	60	1120	68	0.30	1965	0	1155	0.00
2	230	60	1115	69	0.30	1755	15	1035	0.06
3	230	60	1100	71	0.31	1490	30	880	0.12
4	230	60	1085	77	0.33	1075	45	630	0.18

U = Power supply · f = Frequency · n = Speed (rpm) · Pe = Power consumption · I = Current draw · qv = Air flow · ps = Pressure increase

