

AC axial fan - HyBlade

sickle-shaped blades (S series)

with guard grille for full nozzle

S6D910-BB05-08 ebmpapst Datasheet

sales@fansco.com

www.fansco.com

Limited partnership · Headquarters Muldingen

Amtsgericht (court of registration) Stuttgart · HRA 590344

General partner Elektrobau Muldingen GmbH · Headquarters Muldingen

Amtsgericht (court of registration) Stuttgart · HRB 590142

Nominal data

Type	S6D910-BB05-08				
Motor	M6D138-NA				
Phase		3~	3~	3~	3~
Nominal voltage	VAC	230	400	400	480
Wiring		Δ	Y	Y	Y
Frequency	Hz	50	50	60	60
Method of obtaining data		ml	ml	ml	ml
Valid for approval/standard		CE	CE	CE	CE
Speed (rpm)	min ⁻¹	925	925	1055	1100
Power consumption	W	1990	1990	2650	2870
Current draw	A	8.1	4.67	5.08	5.13
Max. back pressure	Pa	160	160	130	140
Max. back pressure	in. wg	0.64	0.64	0.52	0.56
Min. ambient temperature	°C	-40	-40	-40	-40
Max. ambient temperature	°C	70	70	45	45
Starting current	A	33	19	17	21.5

ml = Max. load · me = Max. efficiency · fa = Free air · cs = Customer specification · ce = Customer equipment
Subject to change

Data according to Commission Regulation (EU) 327/2011 (EN 17166)

		Actual	Req. 2015			
01 Overall efficiency η_{es}	%	39.1	35.5	09 Power consumption P_e	kW	1.93
02 Measurement category		A		09 Air flow q_v	m ³ /h	18700
03 Efficiency category		Static		09 Pressure increase p_{fs}	Pa	146
04 Efficiency grade N		43.6	40	10 Speed (rpm) n	min ⁻¹	925
05 Variable speed drive		No		11 Specific ratio*		1.00

Data obtained at optimum efficiency level.
The ErP data is determined using a motor-impeller combination in a standardized measurement setup.

* Specific ratio = $1 + p_s / 100\,000\text{ Pa}$

LU-118443



AC axial fan - HyBlade

sickle-shaped blades (S series)

with guard grille for full nozzle

Technical description

Weight	35 kg
Size	910 mm
Motor size	138
Rotor surface	Cast in aluminum
Terminal box material	PP plastic
Blade material	Sheet aluminum insert, sprayed with PP plastic
Guard grille material	Steel, coated with black plastic (RAL 9005)
Number of blades	5
Blade pitch	-5°
Airflow direction	V
Direction of rotation	Clockwise, viewed toward rotor
Degree of protection	IP54
Insulation class	"F"
Moisture (F) / Environmental (H) protection class	H2
Ambient temperature note	Occasional start-up at temperatures between -40°C and -25°C is permitted. For continuous operation at ambient temperatures below -25°C (such as refrigeration applications), use must be made of a fan design with special low-temperature bearings.
Max. permitted ambient temp. for motor (transport/storage)	+80 °C
Min. permitted ambient temp. for motor (transport/storage)	-40 °C
Installation position	Any
Condensation drainage holes	On rotor and stator sides
Mode	S1
Motor bearing	Ball bearing
Touch current according to IEC 60990 (measuring circuit Fig. 4, TN system)	<= 3.5 mA
Electrical hookup	Terminal box
Motor protection	Thermal overload protector (TOP) with basic insulation
Protection class	I (with customer connection of protective earth)
Conformity with standards	EN 60034-1 (2010); CE
Approval	CSA C22.2 No. 100; UL 1004-1; EAC



S6D910-BB05-08

AC axial fan - HyBlade

sickle-shaped blades (S series)

with guard grille for full nozzle

Product drawing

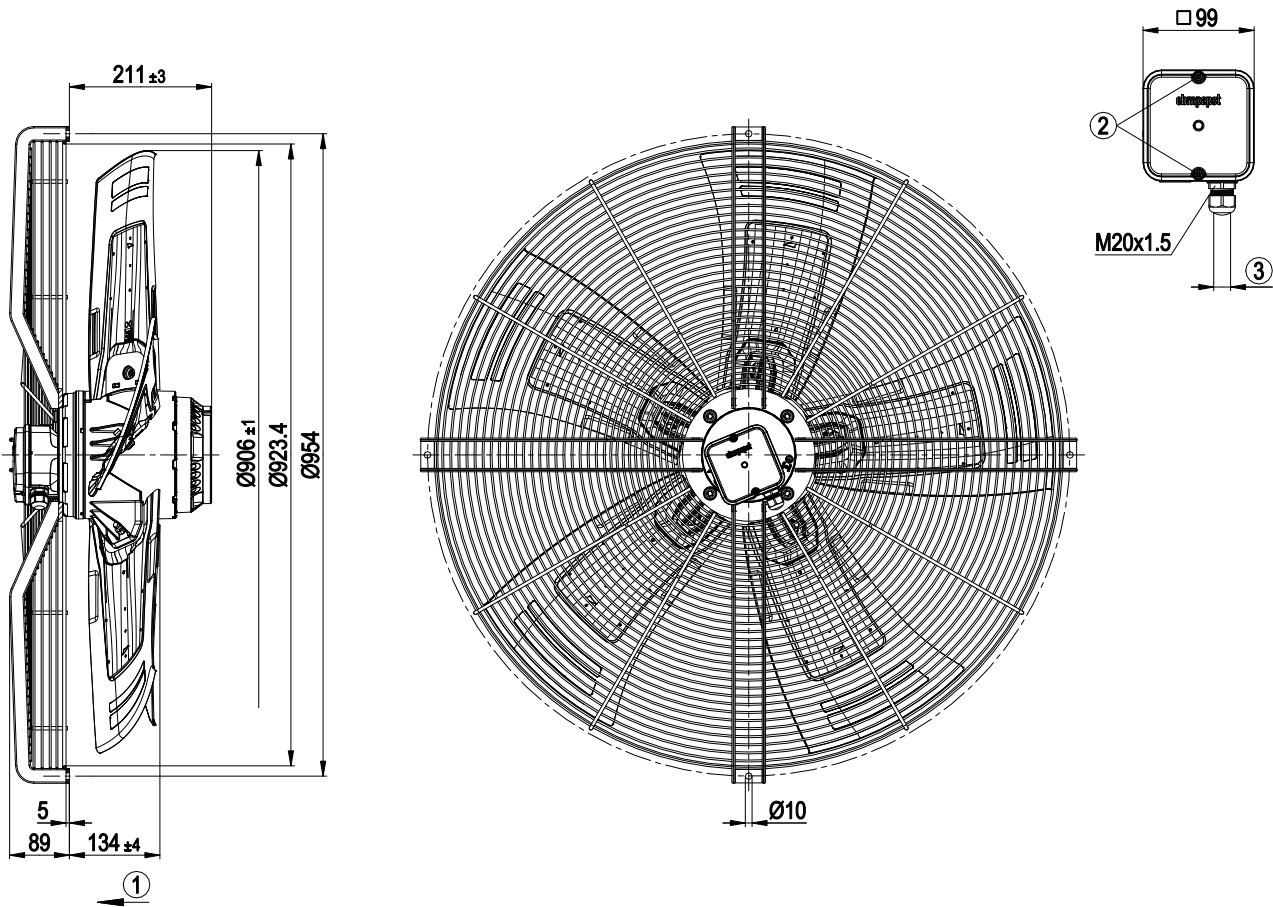

1	Direction of air flow "V"
2	Tightening torque 1.5 ± 0.2 Nm
3	Cable diameter min. 7 mm, max. 14 mm, tightening torque 2 ± 0.3 Nm



AC axial fan - HyBlade

sickle-shaped blades (S series)

with guard grille for full nozzle

Connection diagram



Δ	Delta connection	Y	Star connection	L1	= U1 = black
L2	= V1 = blue	L3	= W1 = brown	W2	yellow
U2	green	V2	white	TOP	2x gray
PE	green/yellow				



AC axial fan - HyBlade

sickle-shaped blades (S series)

with guard grille for full nozzle

Curves: Air performance 50 Hz

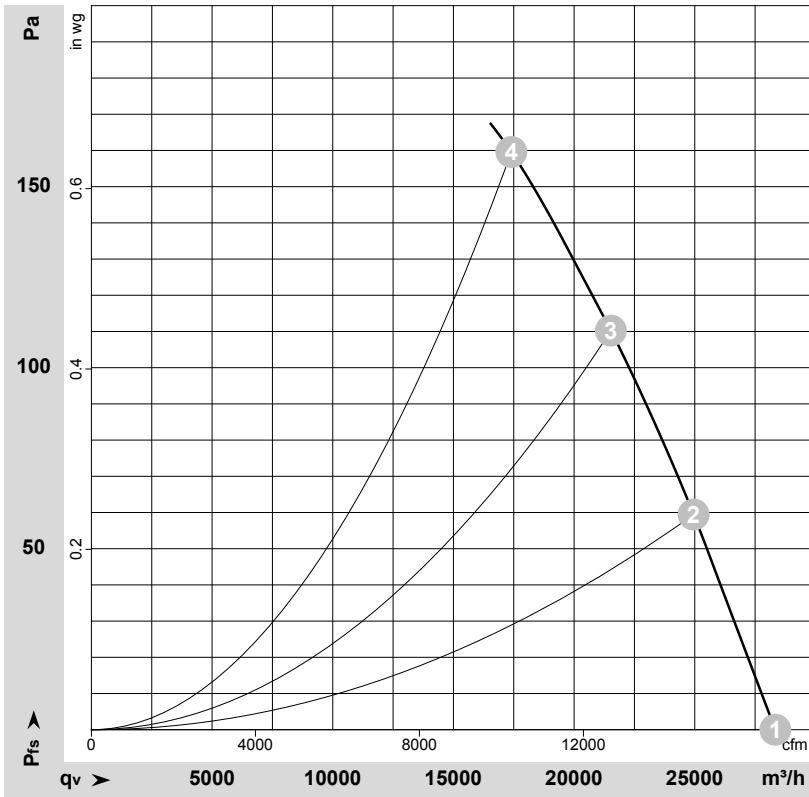

$\rho = 1.15 \text{ kg/m}^3 \pm 2 \%$

Measurement: LU-118443-1

Air performance measured according to ISO 5801 installation category A. For detailed information on the measurement setup, contact ebm-papst. Intake sound level: Sound power level according to ISO 13347 / sound pressure level measured at 1 m distance from fan axis. The values given are valid under the specified measuring conditions and may vary due to conditions of installation. For deviations from the standard configuration, the parameters have to be checked on the installed unit.

Measured values

	Wired	U	f	n	P _e	I	LpA _{in}	LwA _{in}	LwA _{out}	q _v	p _{fs}	q _v	p _{fs}
		V	Hz	min ⁻¹	W	A	dB(A)	dB(A)	dB(A)	m ³ /h	Pa	cfm	in. wg
1	Y	400	50	955	1284	3.98	71	79	79	28340	0	16680	0.00
2	Y	400	50	945	1584	4.21	69	76	76	24950	60	14685	0.24
3	Y	400	50	935	1799	4.43	68	76	75	21525	110	12670	0.44
4	Y	400	50	925	1990	4.67	72	79	79	17400	160	10240	0.64

Wired = Wiring · U = Voltage · f = Frequency · n = Speed (rpm) · P_e = Power consumption · I = Current draw · LpA_{in} = Sound pressure level intake side · LwA_{in} = Sound power level intake side
 LwA_{out} = Sound power level outlet side · q_v = Air flow · p_{fs} = Pressure increase



AC axial fan - HyBlade

sickle-shaped blades (S series)

with guard grille for full nozzle

Curves: Air performance 60 Hz

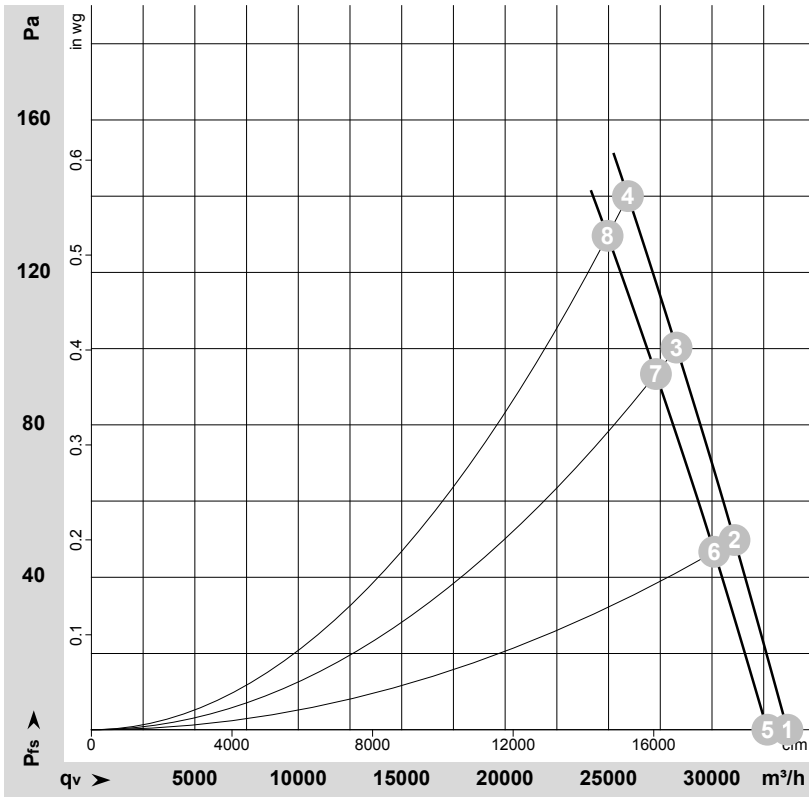

$\rho = 1.15 \text{ kg/m}^3 \pm 2 \%$

Measurement: LU-118449-1
Measurement: LU-118450-1

Air performance measured according to ISO 5801 installation category A. For detailed information on the measurement setup, contact ebmpapst. Intake sound level: Sound power level according to ISO 13347 / sound pressure level measured at 1 m distance from fan axis. The values given are valid under the specified measuring conditions and may vary due to conditions of installation. For deviations from the standard configuration, the parameters have to be checked on the installed unit.

Measured values

	Wired	U	f	n	P _e	I	LpA _{in}	LwA _{in}	LwA _{out}	q _v	p _{fs}	q _v	p _{fs}
		V	Hz	min ⁻¹	W	A	dB(A)	dB(A)	dB(A)	m ³ /h	Pa	cfm	in. wg
1	Y	480	60	1130	2073	4.26	76	83	83	33645	0	19805	0.00
2	Y	480	60	1120	2372	4.56	74	82	82	31090	50	18300	0.20
3	Y	480	60	1110	2650	4.86	73	81	81	28285	100	16650	0.40
4	Y	480	60	1100	2870	5.13	73	80	80	25935	140	15265	0.56
5	Y	400	60	1105	1933	3.98	75	83	83	32675	0	19230	0.00
6	Y	400	60	1090	2216	4.39	73	81	81	30110	47	17720	0.19
7	Y	400	60	1070	2469	4.79	72	80	80	27290	93	16060	0.37
8	Y	400	60	1055	2650	5.08	72	79	79	24955	130	14685	0.52

Wired = Wiring · U = Voltage · f = Frequency · n = Speed (rpm) · P_e = Power consumption · I = Current draw · LpA_{in} = Sound pressure level intake side · LwA_{in} = Sound power level intake side
LwA_{out} = Sound power level outlet side · q_v = Air flow · p_{fs} = Pressure increase

