

S6D800-LH15-06 ebmpapst Datasheet

sales@fansco.com

www.fansco.com

Limited partnership · Headquarters Mulfingen

Amtsgericht (court of registration) Stuttgart · HRA 590344

General partner Elektrobau Mulfingen GmbH · Headquarters Mulfingen

Amtsgericht (court of registration) Stuttgart · HRB 590142

Nominal data

Type	S6D800-LH15-06		
Motor	M6D138-HF		
Phase		3~	3~
Nominal voltage	VAC	400	400
Wiring		Δ	Y
Frequency	Hz	50	50
Method of obtaining data		ml	ml
Valid for approval/standard		CE	CE
Speed (rpm)	min ⁻¹	870	620
Power consumption	W	1130	675
Current draw	A	2.2	1.3
Max. back pressure	Pa	140	70
Max. back pressure	in. wg	0.56	0.28
Min. ambient temperature	°C	-40	-40
Max. ambient temperature	°C	60	60
Starting current	A	6.7	2.0

ml = Max. load · me = Max. efficiency · fa = Free air · cs = Customer specification · ce = Customer equipment
Subject to change

Data according to Commission Regulation (EU) 327/2011 (EN 17166)

		Actual	Req. 2015			
01 Overall efficiency η_{es}	%	40.7	33.8	09 Power consumption P_e	kW	1.06
02 Measurement category		A		09 Air flow q_v	m ³ /h	13790
03 Efficiency category		Static		09 Pressure increase p_{fs}	Pa	118
04 Efficiency grade N		46.9	40	10 Speed (rpm) n	min ⁻¹	880
05 Variable speed drive		No		11 Specific ratio*		1.00

Data obtained at optimum efficiency level.
The ErP data is determined using a motor-impeller combination in a standardized measurement setup.

* Specific ratio = $1 + p_{fs} / 100\,000\text{ Pa}$

LU-204561



Technical description

Weight	28.7 kg
Size	800 mm
Motor size	138
Rotor surface	Cast in aluminum
Terminal box material	PP plastic
Blade material	PP plastic
Guard grille material	Steel, coated with black plastic (RAL 9005)
Number of blades	5
Blade pitch	-2.5°
Airflow direction	V
Direction of rotation	Clockwise, viewed toward rotor
Degree of protection	IP54
Insulation class	"F"
Moisture (F) / Environmental (H) protection class	H2
Ambient temperature note	Occasional start-up at temperatures between -40°C and -25°C is permitted. For continuous operation at ambient temperatures below -25°C (such as refrigeration applications), use must be made of a fan design with special low-temperature bearings.
Max. permitted ambient temp. for motor (transport/storage)	+80 °C
Min. permitted ambient temp. for motor (transport/storage)	-40 °C
Installation position	Any
Condensation drainage holes	On rotor and stator sides
Mode	S1
Motor bearing	Ball bearing
Touch current according to IEC 60990 (measuring circuit Fig. 4, TN system)	< 0.75 mA
Electrical hookup	Connector with cable
Motor protection	Thermal overload protector (TOP) with basic insulation
Protection class	I (with customer connection of protective earth)
Conformity with standards	EN 60034-1 (2010); CE
Approval	VDE; EAC

AC axial fan - AxiBlade

sickle-shaped blades (S series)
with guard grille for full nozzle

Product drawing

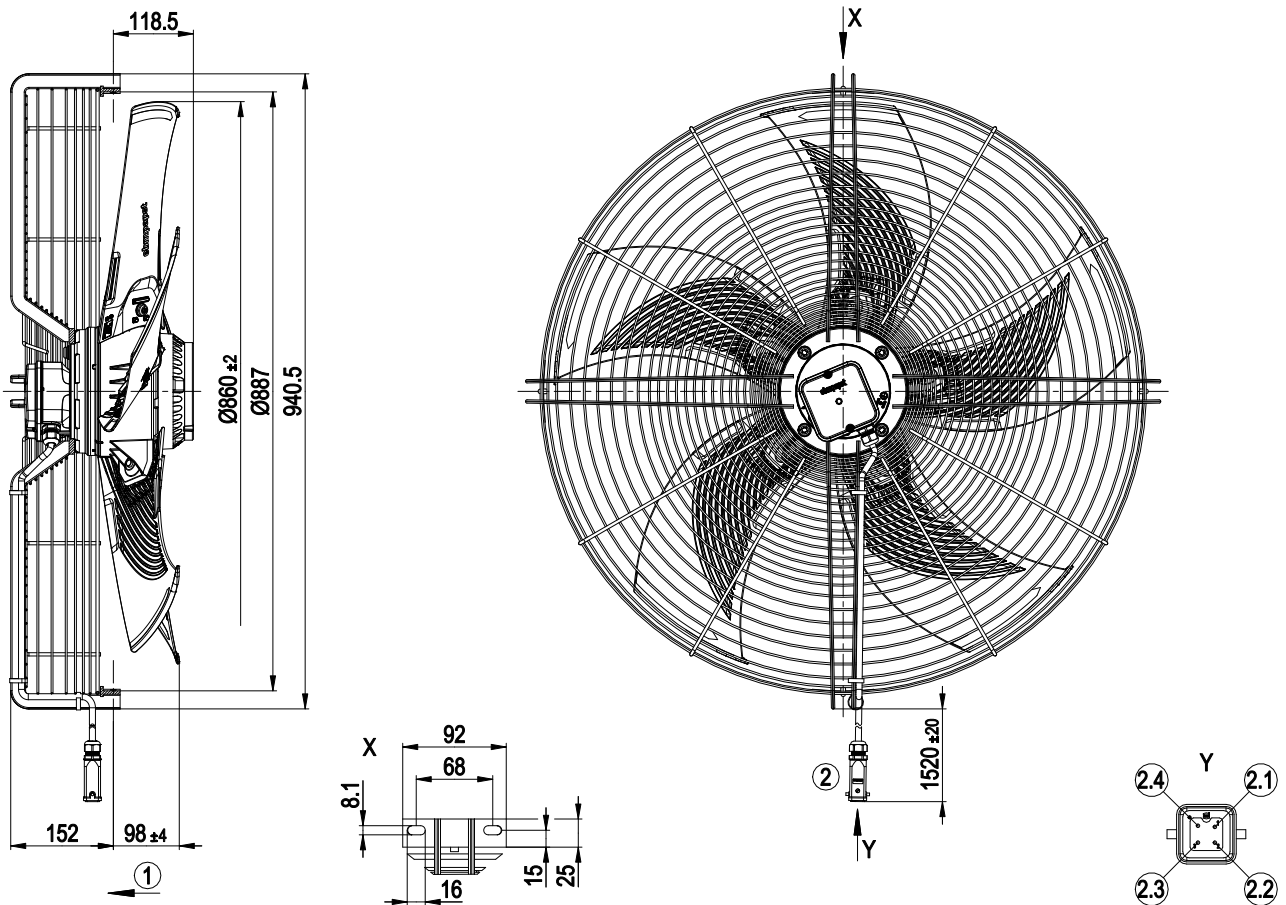

1	Airflow direction "V"
2	Cable Ölflex Heat 105 MC 4G 1.5 mm ² Connector housing WESTEC 7803.6227.1, 4-pole pin insert WESTEC 7203.6101.0
2.1	L1
2.2	L2
2.3	L3
2.4	PE



AC axial fan - AxiBlade

sickle-shaped blades (S series)
with guard grille for full nozzle

Connection diagram

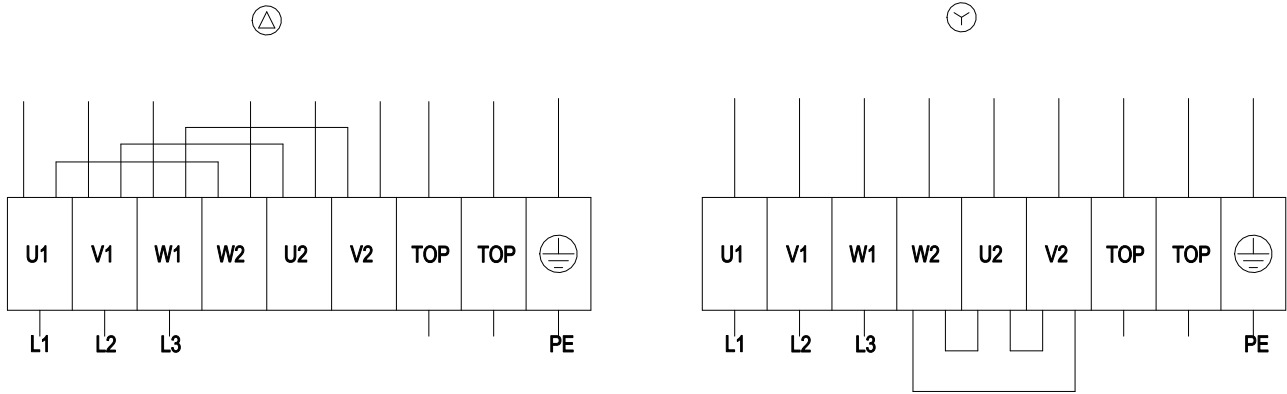

Δ	Delta connection	Y	Star connection	L1	= U1 = black
L2	= V1 = blue	L3	= W1 = brown	W2	yellow
U2	green	V2	white	TOP	2x gray
PE	green/yellow				



AC axial fan - AxiBlade

sickle-shaped blades (S series)

with guard grille for full nozzle

Curves: Air performance 50 Hz

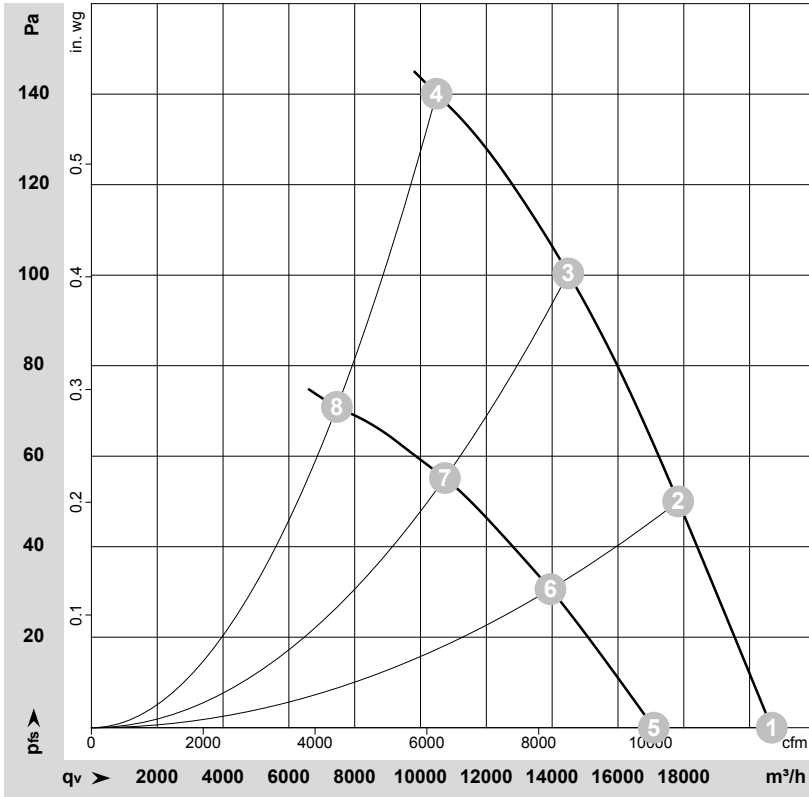

$\rho = 1.15 \text{ kg/m}^3 \pm 2 \%$

Measurement: LU-204550-1
Measurement: LU-204558-1

Air performance measured according to ISO 5801 installation category A. For detailed information on the measurement setup, contact ebm-papst. Intake sound level: Sound power level according to ISO 13347 / sound pressure level measured at 1 m distance from fan axis. The values given are valid under the specified measuring conditions and may vary due to conditions of installation. For deviations from the standard configuration, the parameters have to be checked on the installed unit.

Measured values

	Wired	U	f	n	P _e	I	LpA _{in}	LwA _{in}	LwA _{out}	q _v	p _{fs}	q _v	p _{fs}
		V	Hz	min ⁻¹	W	A	dB(A)	dB(A)	dB(A)	m ³ /h	Pa	cfm	in. wg
1	Δ	400	50	925	745	1.65	68	74	74	20675	0	12170	0.00
2	Δ	400	50	905	904	1.86	66	73	73	17830	50	10495	0.20
3	Δ	400	50	885	1035	2.04	68	74	74	14490	100	8530	0.40
4	Δ	400	50	870	1130	2.20	75	82	83	10490	140	6175	0.56
5	Y	400	50	765	554	1.06	63	69	69	17090	0	10060	0.00
6	Y	400	50	705	620	1.20	60	67	66	13950	31	8210	0.12
7	Y	400	50	655	657	1.28	61	67	67	10740	55	6320	0.22
8	Y	400	50	620	675	1.30	65	72	73	7460	70	4390	0.28

Wired = Wiring · U = Voltage · f = Frequency · n = Speed (rpm) · P_e = Power consumption · I = Current draw · LpA_{in} = Sound pressure level intake side · LwA_{in} = Sound power level intake side
LwA_{out} = Sound power level outlet side · q_v = Air flow · p_{fs} = Pressure increase

