

S6D800-CH01-16 ebmpapst Datasheet

sales@fansco.com

www.fansco.com

Limited partnership · Headquarters Mulfingen

Amtsgericht (court of registration) Stuttgart · HRA 590344

General partner Elektrobau Mulfingen GmbH · Headquarters Mulfingen

Amtsgericht (court of registration) Stuttgart · HRB 590142

## Nominal data

Type	S6D800-CH01-16		
Motor	M6D138-HF		
Phase		3~	3~
Nominal voltage	VAC	400	400
Wiring		$\Delta$	Y
Frequency	Hz	50	50
Method of obtaining data		ml	ml
Valid for approval/standard		CE	CE
Speed (rpm)	min <sup>-1</sup>	850	610
Power consumption	W	1440	820
Current draw	A	2.9	1.6
Max. back pressure	Pa	150	80
Max. back pressure	in. wg	0.6	0.32
Min. ambient temperature	°C	-40	-40
Max. ambient temperature	°C	60	60
Starting current	A	9	3

ml = Max. load · me = Max. efficiency · fa = Free air · cs = Customer specification · ce = Customer equipment  
Subject to change

## Data according to Commission Regulation (EU) 327/2011

		Actual	Req. 2015			
01 Overall efficiency $\eta_{es}$	%	35.5	34.4	09 Power consumption $P_e$	kW	1.29
02 Measurement category		A		09 Air flow $q_v$	m <sup>3</sup> /h	13595
03 Efficiency category		Static		09 Pressure increase $p_{fs}$	Pa	122
04 Efficiency grade N		41.1	40	10 Speed (rpm) n	min <sup>-1</sup>	870
05 Variable speed drive		No		11 Specific ratio*		1.00

Data obtained at optimum efficiency level.  
The ErP data is determined using a motor-impeller combination in a standardized measurement setup.

\* Specific ratio =  $1 + p_{fs} / 100\,000\text{ Pa}$ 

LU-115455



# AC axial fan - HyBlade

sickle-shaped blades (S series)

with guard grille for full nozzle

## Technical description

<b>Weight</b>	27 kg
<b>Size</b>	800 mm
<b>Motor size</b>	138
<b>Rotor surface</b>	Cast in aluminum
<b>Terminal box material</b>	PP plastic
<b>Blade material</b>	Sheet aluminum insert, sprayed with PP plastic
<b>Guard grille material</b>	Steel, coated with black plastic (RAL 9005)
<b>Number of blades</b>	5
<b>Blade pitch</b>	-5°
<b>Airflow direction</b>	V
<b>Direction of rotation</b>	Clockwise, viewed toward rotor
<b>Degree of protection</b>	IP54
<b>Insulation class</b>	"F"
<b>Moisture (F) / Environmental (H) protection class</b>	H2
<b>Ambient temperature note</b>	Occasional start-up at temperatures between -40°C and -25°C is permitted. For continuous operation at ambient temperatures below -25°C (such as refrigeration applications), use must be made of a fan design with special low-temperature bearings.
<b>Max. permitted ambient temp. for motor (transport/storage)</b>	+80 °C
<b>Min. permitted ambient temp. for motor (transport/storage)</b>	-40 °C
<b>Installation position</b>	Any
<b>Condensation drainage holes</b>	On rotor and stator sides
<b>Mode</b>	S1
<b>Motor bearing</b>	Ball bearing
<b>Touch current according to IEC 60990 (measuring circuit Fig. 4, TN system)</b>	<= 3.5 mA
<b>Electrical hookup</b>	Terminal box with cable
<b>Motor protection</b>	Thermal overload protector (TOP) with basic insulation
<b>Protection class</b>	I (with customer connection of protective earth)
<b>Conformity with standards</b>	EN 60034-1 (2010); CE
<b>Approval</b>	VDE; EAC



# AC axial fan - HyBlade

sickle-shaped blades (S series)  
with guard grille for full nozzle

## Product drawing

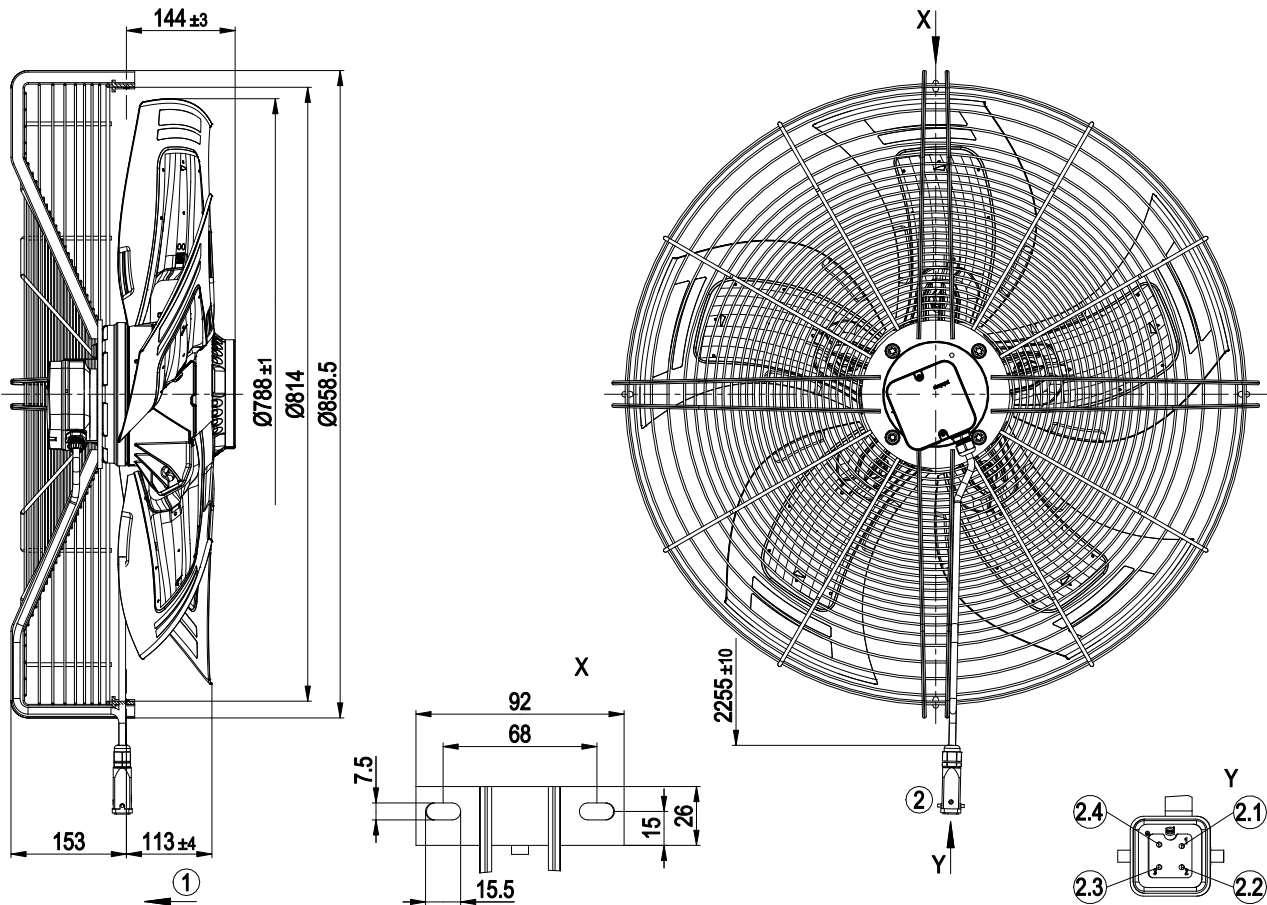

1	Airflow direction "V"
2	Cable Ölflex Heat 105 MC 4G 1.5 mm <sup>2</sup> with connector housing WESTEC 7803.6227.1 and 4-pole pin insert WESTEC 7203.6101.0
2.1	L1 = 1
2.2	L2 = 2
2.3	L3 = 3
2.4	PE



# AC axial fan - HyBlade

sickle-shaped blades (S series)

with guard grille for full nozzle

## Connection diagram



Δ	Delta connection	Y	Star connection	L1	= U1 = black
L2	= V1 = blue	L3	= W1 = brown	W2	yellow
U2	green	V2	white	TOP	2x gray
PE	green/yellow				



# AC axial fan - HyBlade

sickle-shaped blades (S series)

with guard grille for full nozzle

## Curves: Air performance 50 Hz

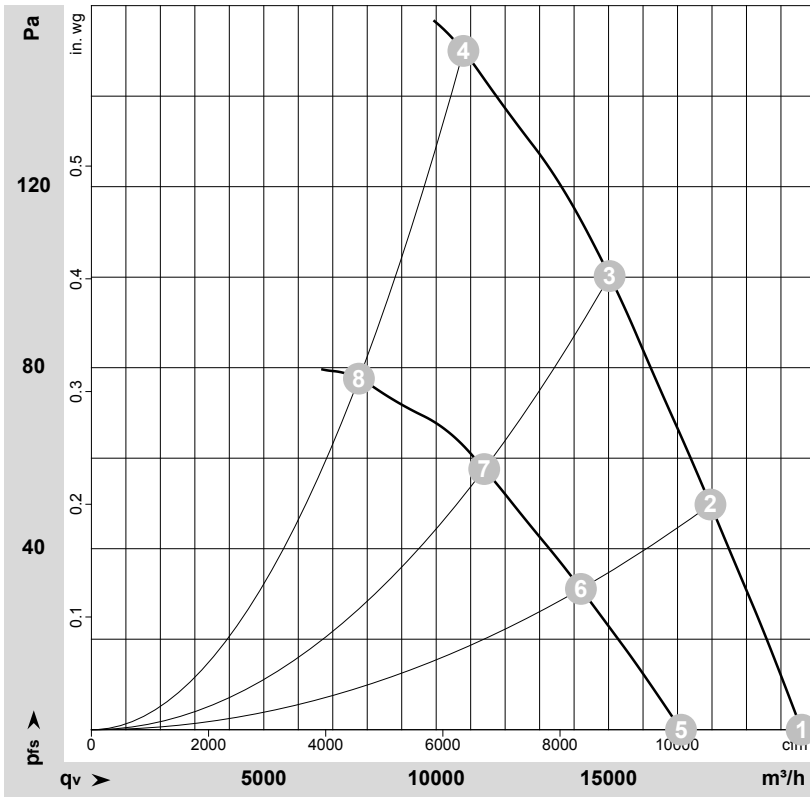

$\rho = 1.185 \text{ kg/m}^3 \pm 2 \%$

Measurement: LU-115455-1  
Measurement: LU-115453-1

Air performance measured according to ISO 5801 installation category A. For detailed information on the measurement setup, contact ebm-papst. Intake sound level: Sound power level according to ISO 13347 / sound pressure level measured at 1 m distance from fan axis. The values given are valid under the specified measuring conditions and may vary due to conditions of installation. For deviations from the standard configuration, the parameters have to be checked on the installed unit.

## Measured values

	Wired	U	f	n	P <sub>e</sub>	I	LpA <sub>in</sub>	LwA <sub>in</sub>	LwA <sub>out</sub>	q <sub>v</sub>	p <sub>fs</sub>	q <sub>v</sub>	p <sub>fs</sub>
		V	Hz	min <sup>-1</sup>	W	A	dB(A)	dB(A)	dB(A)	m <sup>3</sup> /h	Pa	cfm	in. wg
1	Δ	400	50	910	940	2.26	66	73	72	20600	0	12125	0.00
2	Δ	400	50	895	1112	2.48	63	69	69	17955	50	10570	0.20
3	Δ	400	50	875	1248	2.64	65	71	70	15030	100	8845	0.40
4	Δ	400	50	850	1440	2.90	69	76	76	10790	150	6350	0.60
5	Y	400	50	760	665	1.29	62	68	68	17100	0	10065	0.00
6	Y	400	50	710	731	1.42	57	64	63	14200	31	8355	0.12
7	Y	400	50	665	776	1.52	57	64	63	11395	58	6705	0.23
8	Y	400	50	610	820	1.60	60	68	67	7760	78	4565	0.31

Wired = Wiring · U = Voltage · f = Frequency · n = Speed (rpm) · P<sub>e</sub> = Power consumption · I = Current draw · LpA<sub>in</sub> = Sound pressure level intake side · LwA<sub>in</sub> = Sound power level intake side  
LwA<sub>out</sub> = Sound power level outlet side · q<sub>v</sub> = Air flow · p<sub>fs</sub> = Pressure increase

